



# PRADO

AUTOMAÇÃO INDUSTRIAL

## SINODRIVE90 AC DRIVE



<https://pradoautomacaoindustrial.com.br>

email: [vendas@pradoindustrial.com.br](mailto:vendas@pradoindustrial.com.br)

(11) 5666-6461 / (11) 94242-8989 - WhatsApp



# PRADO

AUTOMAÇÃO INDUSTRIAL

## CONTENTS

<b>About Model</b> .....	<b>01</b>
<b>Naming rules</b> .....	<b>03</b>
<b>Outline Diagram</b> .....	<b>03</b>
<b>Installation Size</b> .....	<b>04</b>
<b>Technical Data</b> .....	<b>05</b>
<b>Technical Specification</b> .....	<b>05</b>
<b>Basic Wiring Diagram</b> .....	<b>06</b>
<b>Wiring Terminal</b> .....	<b>07</b>
<b>Keyboard</b> .....	<b>09</b>
<b>Accessories</b> .....	<b>10</b>
<b>Peripheral Equipment</b> .....	<b>11</b>
<b>Application Industry</b> .....	<b>12</b>



<https://pradoautomacaoindustrial.com.br>

email: [vendas@pradoindustrial.com.br](mailto:vendas@pradoindustrial.com.br)

(11) 5666-6461 / (11) 94242-8989 - WhatsApp



# PRADO

AUTOMAÇÃO INDUSTRIAL

## About Model

### Workmanship / Advanced Equipment



■ Professional assembly line, three – proofing lacquer treatment process is Dust – proof, moisture–proof, mildew – proof, 7S perfect management system, advanced Process Control, Standard operation process, professional testing equipment and powerful technology support to make sure satisfactory products and service for all customers.

### Quality Assurance / CE Certificate



■ We are very focused on the internal management and quality control, we pass CE, ISO9001: 2008, etc.





# PRADO

AUTOMAÇÃO INDUSTRIAL

## About Model



### Structure design / Enclosed space/Independent air channel



The air channel is independently separated from the body of model, the enclosed space make sure all the air go through the cooler and achieve the best performance in cooling, in which reduce the temperature of the body part and improve the performance of model, reduce the rate of failure and prolong the life of model.

### User-friendly / Simple operation



Keypad is user friendly, optional communication wires.



# PRADO

AUTOMAÇÃO INDUSTRIAL

## Naming Rules

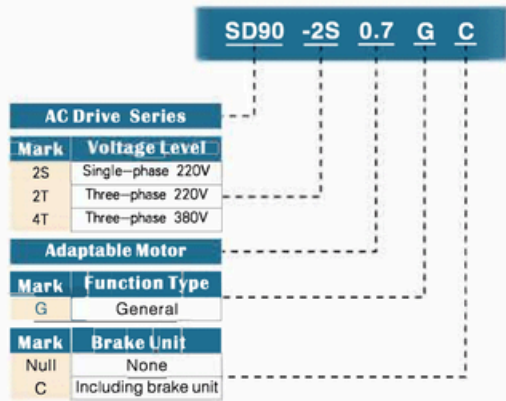

**Naming Rules**



**Nameplate**

## Outline Diagram

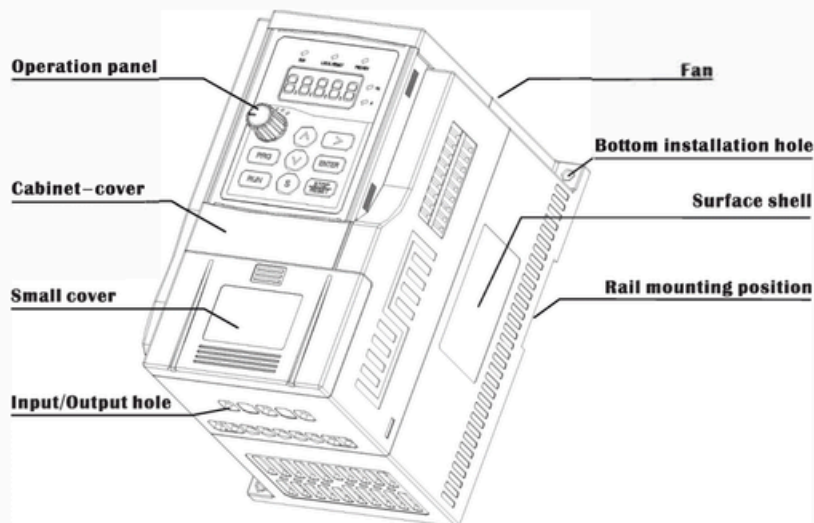



## Installation Size

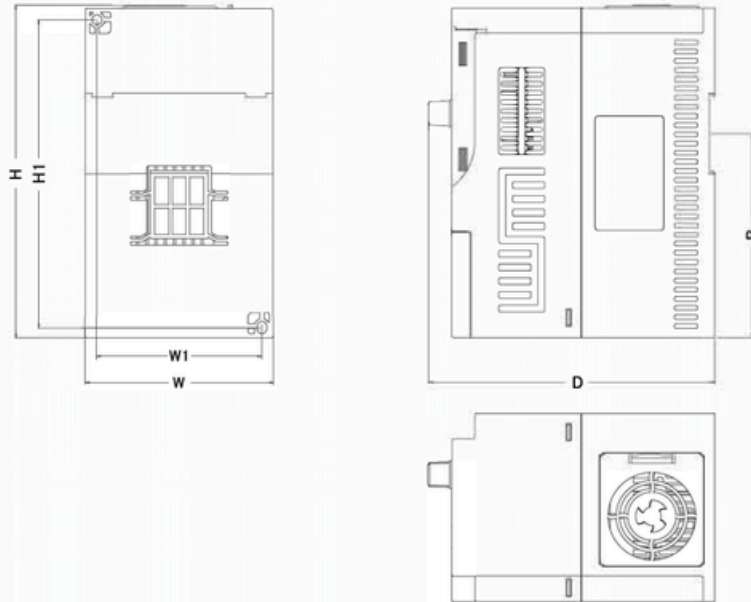

Model Number	H(mm)	W(mm)	D(mm)	H1(mm)	W1(mm)	B(mm)	Bore(mm)	G.W(kg)
<b>SD90-2S :0.7KW-2.2KW Single-phase 220V</b>								
SD90-2S-0.7G	145	82	115	135	72	89	Φ4	0.9
SD90-2S-1.5G	145	82	115	135	72	89	Φ4	0.9
SD90-2S-2.2G	190	110	152	178	98	*	Φ5	1.95
<b>SD90-2T :0.7KW-2.2KW Three-phase 220V</b>								
SD90-2T-0.7G	145	82	115	135	72	89	Φ4	0.9
SD90-2T-1.5G	145	82	115	135	72	89	Φ4	0.9
SD90-2T-2.2G	190	110	152	178	98	*	Φ5	1.95
<b>SD90-4T :0.7KW-4.0KW Three-phase 80V</b>								
SD90-4T-0.7G	145	82	115	135	72	89	Φ4	0.9
SD90-4T-1.5G	145	82	115	135	72	89	Φ4	0.9
SD90-4T-2.2G	145	82	115	135	72	89	Φ4	0.9
SD90-4T-4.0G	190	110	152	178	98	*	Φ5	1.95

Note: Above dimensions is only for reference. Instructions are subject to change without notice. For more information, please contact SINOVO.



## Technical Data

Model Number	Power capacity (KVA)	Input current (A)	Output current (A)	Adaptable Motor(KW)	Model Number	Power capacity (KVA)	Input current (A)	Output current (A)	Adaptable Motor(KW)
SD90-2S : 0.7KW-2.2KW Single-phase 220V Range: -15%~20%									
SD90-2S-0.7	1.5	8.2	4.7	0.75	SD90-2S-2.2	4.0	23.0	10.0	2.2
SD90-2S-1.5	3.0	14.0	7.5	1.5					
SD90-2T : 0.7KW-2.2KW Three-phase 220V Range: -15%~15%									
SD90-2T-0.7	1.5	5.5	4.7	0.75	SD90-2T-2.2	4.0	12.0	10.0	2.2
SD90-2T-1.5	3.0	7.7	7.5	1.5					
SD90-4T : 0.7KW-4.0KW Three-phase 380V Range: -15%~20%									
SD90-4T-0.7	1.5	3.4	2.3	0.75	SD90-4T-2.2	4.0	5.8	5.1	2.2
SD90-4T-1.5	3.0	5.0	3.7	1.5	SD90-4T-4.0	5.9	10.5	8.5	4.0

## Technical Specification

Item	Specification	
Basic specifications	DC braking	DC braking frequency: 0.00Hz~Maximum frequency Braking time: 0.0 ~ 120.0s Braking action current value: 0.0~150%
	Jog control	Jog frequency range: 0.00Hz~50.00Hz
	Onboard PID	It realizes process-controlled closed loop PID control system easily
	Simple PLC,Multi-stage	16-stage speed through built-in PLC or control terminal
	Auto voltage regulation (AVR)	It can keep constant output voltage automatically when the main voltage changes
	Overvoltage/Overcurrent stall control	The current and voltage are limited automatically during the running process so as to avoid frequent tripping due to overvoltage/overcurrent.
	Rapid current limit function	It helps to avoid frequent over- current faults of the AC drive.
Individualized	High performance	High-performance current vector control technology to achieve a three-phase AC induction motor control.
	Instantaneous non-stop	Load feedback energy compensates the voltage reduction so that the AC drive can continue to run in a short time in case of power interruption.
	Rapid current limit	Rapid software and hardware current limiting technology helps to avoid frequent over-current fault.
Running	Bus support	In accordance with international standard MODBUS communication
	Command source	Given the control panel, control terminal, serial communication port given. It can be switched by a variety of ways.
	Frequency source	9 frequency sources : digital setting, analog voltage setting, analog current setting, pulse setting, 485 communication setting, etc. It can be switched by a variety of ways
	Auxiliary frequency source	9 auxiliary frequency source. Flexible implementation of auxiliary frequency tuning, frequency synthesis.
	Input terminal	Five digital input terminals (S1~S5). One analog input terminal (Ai1) that supports 0~10V voltage input or 0~20mA current input. One high-speed pulse (HDI) that receives max 50kHz frequency high-speed input.
	Output terminal	One digital output terminal. One relay output terminal. One analog output terminal AO that supports 0~20mA current output or 0~10V voltage output
	Key Locking and function selection	Achieve some or all of the keys locked and define the scope of partial keys to prevent misuse.
Protection function	Powered motor short circuit test; Input/output phase failure protection; Over current protection; voltage protection; Under voltage protection; Over heat protection ; Overload protection;braking resistor fault protection.	
Environment	Installation location	Indoor, free from direct sunlight, dust, corrosive gas, combustible gas, oil smoke, vapour, drip or salt
	Altitude	Less than 1000m (derated when use of 1000m~3000m)
	Ambient temperature	-10 +40 (derated use in the ambient temperature of 40°C and 50°C )
	Humidity	Less than 95%RH, without condensing
	Vibration	Less than 5.9m/s <sup>2</sup> (0.6g)
Storage temperature	-20°C to +60°C	

## Basic Wiring Diagram

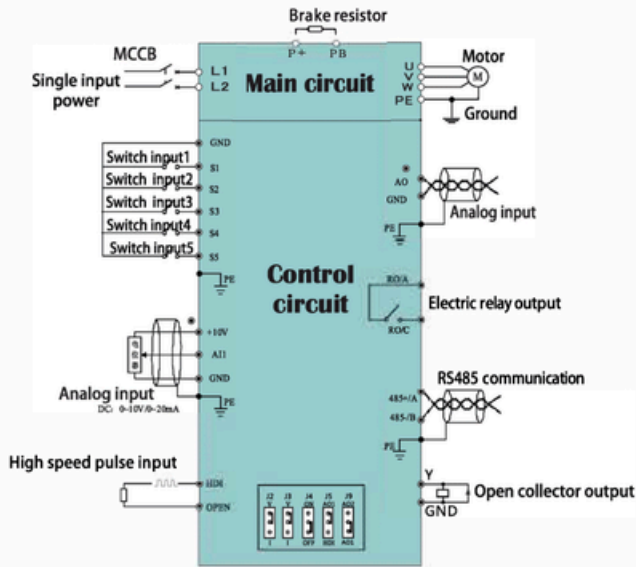

SD90 Single-phase Input Wiring Diagram

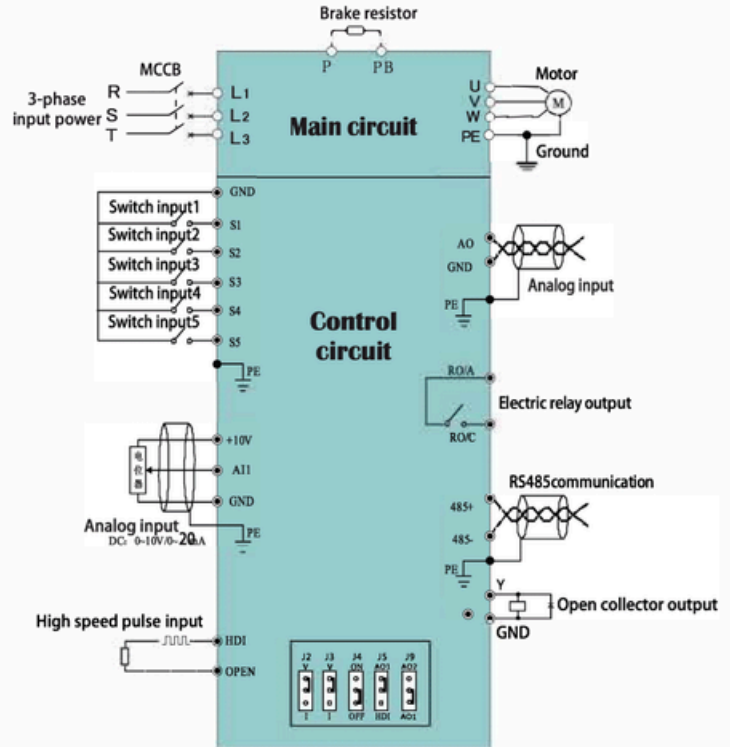

SD90 Three-phase Input Wiring Diagram

Note: The figure "○" is Control circuit terminal "●" is main circuit terminal.





## Wiring Terminal

### 01 Control Circuit Terminals

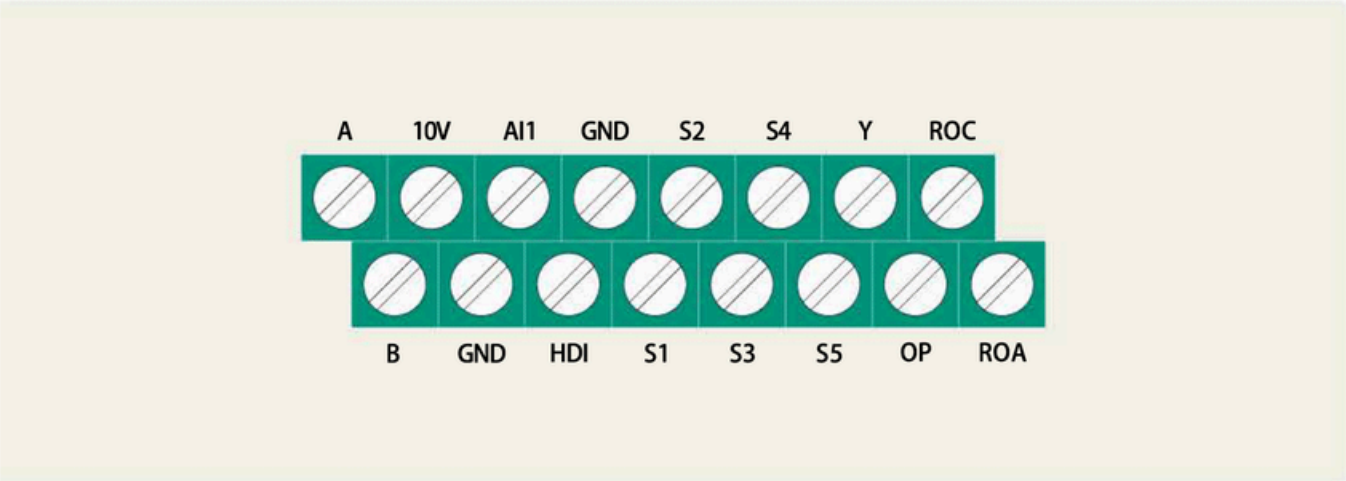

### 02 Control Circuit Terminals Function

Type	Terminal	Name	Technical specifications
Analog input	+10V	Analog input reference voltage	10.5V(±3%) Maximum output current 25mA, Generally, it provides power supply to external potentiometer with resistance range over 4KΩ
	AI1	Analog input	0~20mA: input impedance 500Ω, maximum input current is 25mA 0~10V: input impedance 100Ω, max input voltage 12.5V Input range: 0 – 10 V / 0 – 20 mA, switched by jumper J3 on the control board and factory defaulted as voltage input.
Analog output	AO	Analog output	0~20mA: impedance 200Ω~500Ω 0~10V: impedance: >10kΩ Output range: 0 – 10 V / 4 – 20 mA, switched by jumper J2 on the control board and factory defaulted as voltage output.
Digital input	GND	Analog ground	The public ground of digital input terminals (S1-S5)
	S1~S5	DI-Digital Input 1~5	The specific function of multi-functional input terminals is set by F04.01~F04.05 It's valid when terminals and the GND are closed.
DI-Digital Output	Y	Open collector output	Voltage range: 0~24V Current range: 0~50mA
Relay output	ROA, ROC	Relay output	Normally open contact Contact capacity: 250VAC/3A, 30VDC/3A
High speed pulse	HDI, OP	High-speed pulse input	Pulse input: maximum frequency 50kHz Voltage range: 10V~30V
RS485	A	485 differential signal +	Speed rate: 1200/2400/4800/9600/19200/38400 Using twisted pair or shielded cable. The longest distance is 300 meters.
	B	485 differential signal -	
	GND	485 communicate grounding	



## Wiring Terminal

### 03 Main Circuit Terminals

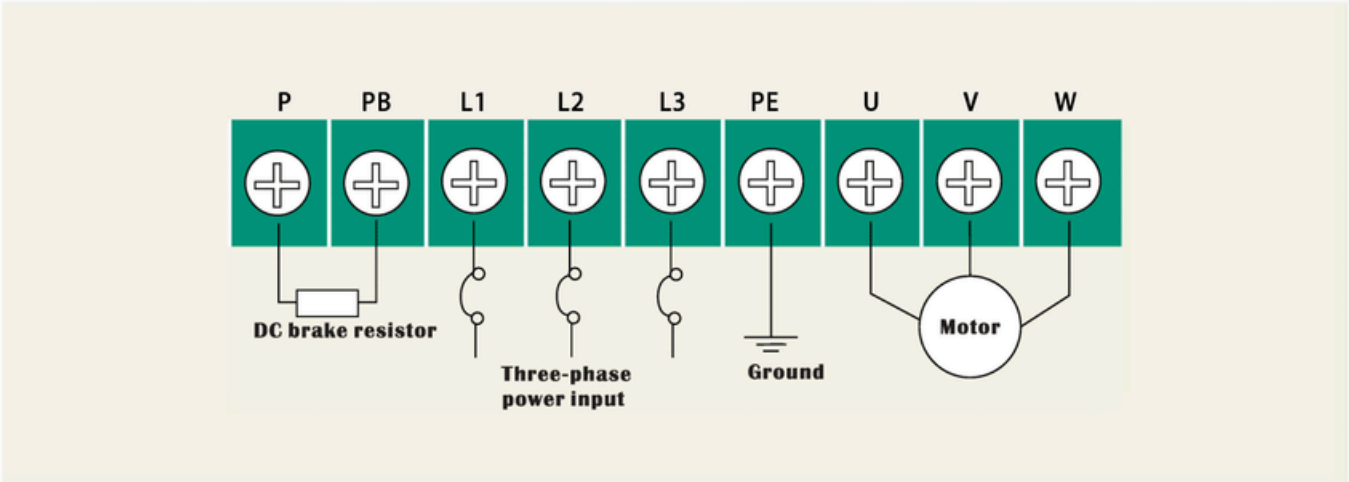

### 04 Main Circuit Terminal Function

Terminal	Input voltage	Name	Description
L1, L2	Single-phase AC drive	Single-phase power supply input terminals	Connect to the single-phase 220 VAC power supply
P, PB		Braking resistor connecting terminal	Braking resistor connecting terminal
U, V, W		AC drive output terminals	Connect to a three-phase motor
PE		Grounding terminal	Must be grounded
L1, L2, L3	Three-phase AC drive	Three-phase power supply input terminals	Connect to the three-phase AC power supply
P, PB		Positive and negative terminals of DC bus	Common DC bus connect terminal
U, V, W		AC drive output terminals	Connect to a three-phase motor
PE		Grounding terminal	Must be grounded



## Keyboard

### 01 Keyboard Size

SD90-KBC

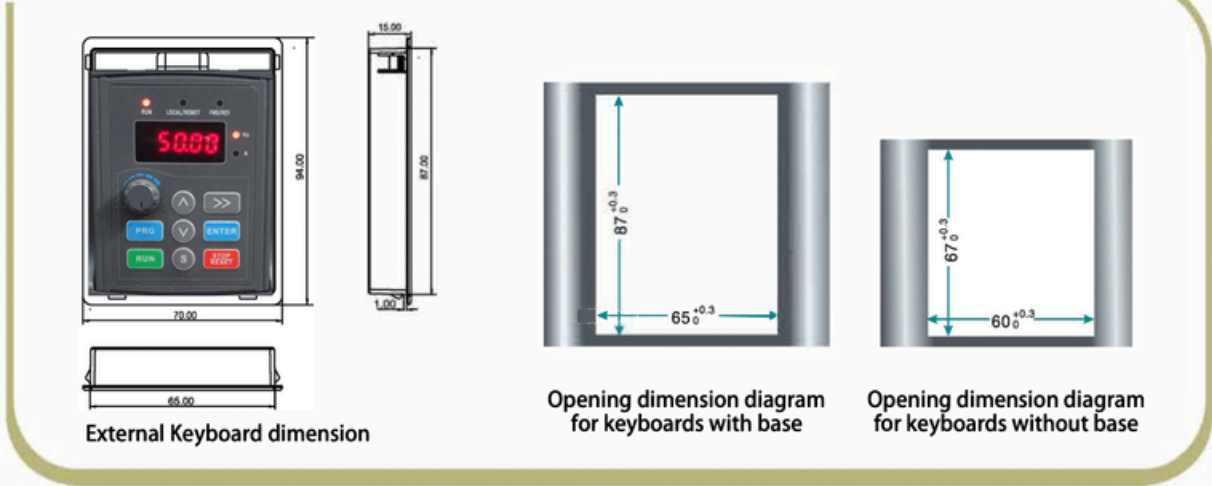

### 02 Function Introduction





Key	Name	Function
	Program key	Enter or exit Level I menu
	Confirm key	Enter the menu interfaces level by level, and confirm the parameter setting
	Stop/Reset key	This key is used to stop in running status and it's limited by function code F06.03. This key used to reset all control modes in the fault alarm state.
	Run key	The key used to operate the AC drive in keypad operation mode.
	Right-Shift key	Move right to select the displaying parameter circularly in stopping and running mode. Select the parameter modifying digit during the parameter modification.
	Increment	Increase data or function code progressively
	Decrement	Decrease data or function code progressively
	S key	The function of this key is confirmed by function code F06.01



## Accessories

### 01 Accessories

Description	Model Number	Picture	Function description
Operation panel network extension cable	KBC-CAB	As following diagram	Connect with LED operation panel, providing up to 20 meters cable
External LED operation panel	See page 9	See page 9	connect external LED operation panel and operation keypad
Single row display keypad base	SD90-KBC-1		connect to external single row keypad to fasten
Dust shield	Depend on model		Dust proof

### 02 Cables

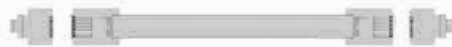
Model	Outline	Standard			Apply to
		Big	Small	Keypad base	
KBC-CAB			Standard		SD90 Series



## Peripheral Equipment

### 01

### Selection of Peripheral Electrical Devices

AC Drive Model	MCCB (A)	Contactor (A)	Cable of Input Side Main Circuit (mm <sup>2</sup> )	Cable of Output Side Main Circuit (mm <sup>2</sup> )	Cable of Control Circuit (mm <sup>2</sup> )
SD90-2S-0.7G	16	10	2.5	2.5	0.75
SD90-2S-1.5G	20	16	4.0	2.5	1.5
SD90-2S-2.2G	32	20	6.0	4.0	1.5
SD90-4T-0.7G	10	10	2.5	2.5	0.75
SD90-4T-1.5G	16	10	2.5	2.5	0.75
SD90-4T-2.2G	16	10	2.5	2.5	0.75
SD90-4T-4.0G	25	16	4.0	4.0	1.5

### 02

### Recommended Values of Braking Resistor

Model	Recommended Power	Recommended Resistance	Braking Unit	Remark
Single-phase 220 V				
SD90-2S-0.7G	80W	≥ 150Ω	Built-in (standard)	Without special description
SD90-2S-1.5G	100W	≥ 100Ω		
SD90-2S-2.2G	250W	≥ 70Ω		
Three-phase 220 V				
SD90-2T-0.7G	80W	≥ 150Ω	Built-in (standard)	Without special description
SD90-2T-1.5G	100W	≥ 100Ω		
SD90-2T-2.2G	250W	≥ 70Ω		
Three-phase 220 V				
SD90-4T-0.7G	150W	≥ 300Ω	Built-in (standard)	Without special description
SD90-4T-1.5G	150W	≥ 220Ω		
SD90-4T-2.2G	250W	≥ 200Ω		
SD90-4T-4.0G	300W	≥ 130Ω		



# PRADO

AUTOMAÇÃO INDUSTRIAL

## Application Industry



Textile



ceramic



Transfer



Slitter machine



Engraving machine



Wire cutting machine



Terminal machine



Grinding machine



Food machine