

## PGL60

PGL60 DRAWING: 1:5 AND 1:10 IS SINGLE STAGE

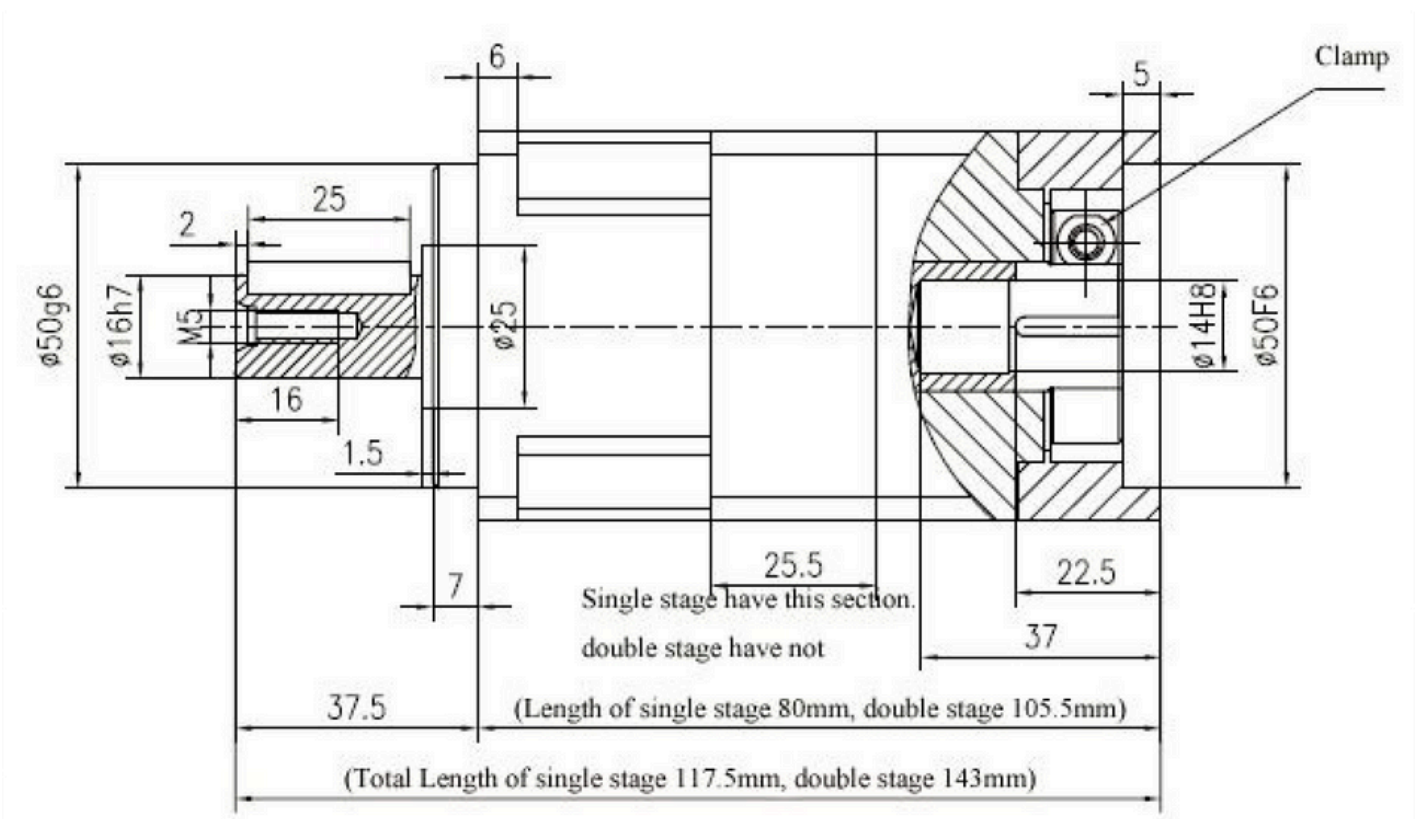
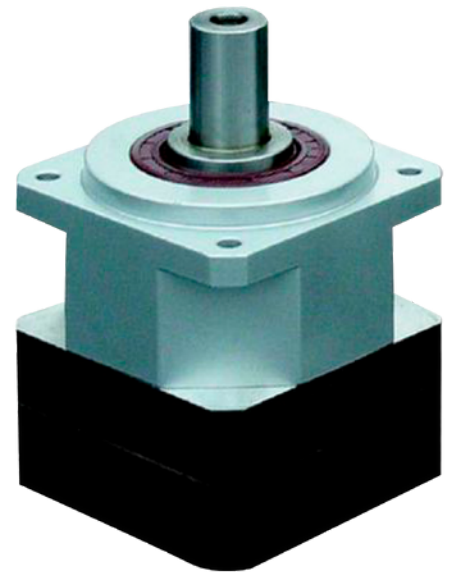

<https://pradoautomacaoindustrial.com.br>

email: vendas@pradoindustrial.com.br

(11) 5666-6461 / (11) 94242-8989 - WhatsApp



# PRADO

AUTOMAÇÃO INDUSTRIAL

## OUTPUT

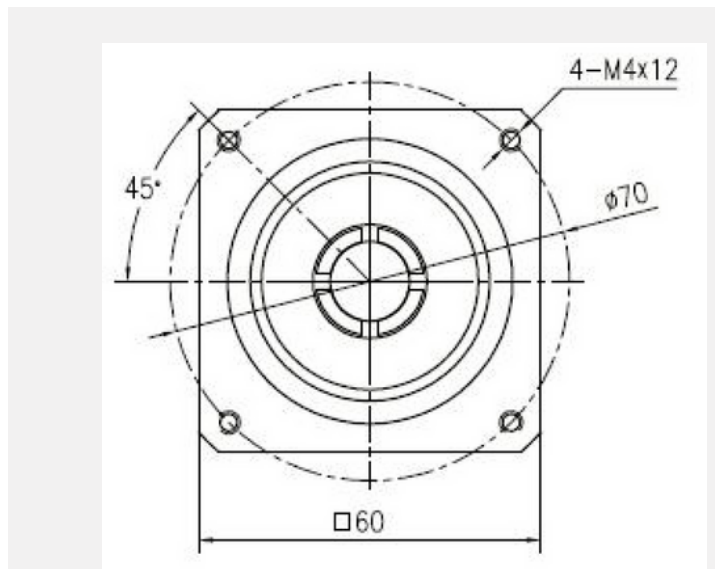

## INPUT

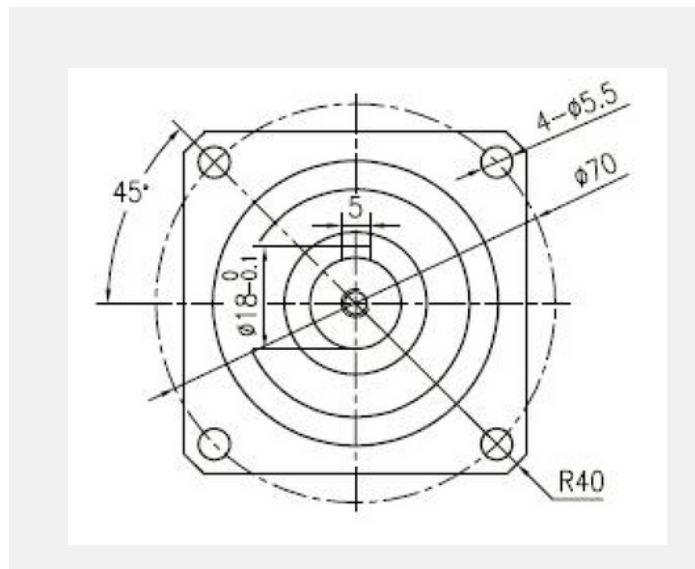

## PGL 60 Specification Table

### Rated Output Torque (N.m)

Ratio	4	5	8	10	16	20	25	32	40	50	64	80	100
PGL60	35.9	43	32.4	17.6	35.9	35.9	43	35.9	32.4	43	35.9	32.4	17.6

Max. Output Torque=3 times of Rated output Torque

Specification	Rated input speed	Max. Input speed	Precision backlash P1	Standard backlash P2	Torsional Rigidity
	(RPM)	(RPM)	(arcmin)	(arcmin)	(N.m/arcmin)
PGL60	3000	6000	<=6(ratio=3-10) <=9(ratio=12-100)	<=9(ratio=3-10) <=12(ratio=12-100)	2.8

Specification	Operating Temp	Service Life	Efficiency	Weight	Noise Level	Protection class
	(°C)	(hr)	(%)	(kg)	(dB/1m)	
PGL60	-10~+90	20000/ (10000 Continue work)	(ratio=3-10)>=96% (ratio=12-100)>=92%	1.2(ratio=3-10) 1.9(ratio=12-100)	<=62	IP65



<https://pradoautomacaoindustrial.com.br>

email: [vendas@pradoindustrial.com.br](mailto:vendas@pradoindustrial.com.br)

(11) 5666-6461 / (11) 94242-8989 - WhatsApp