

# J G2F-6.0KW

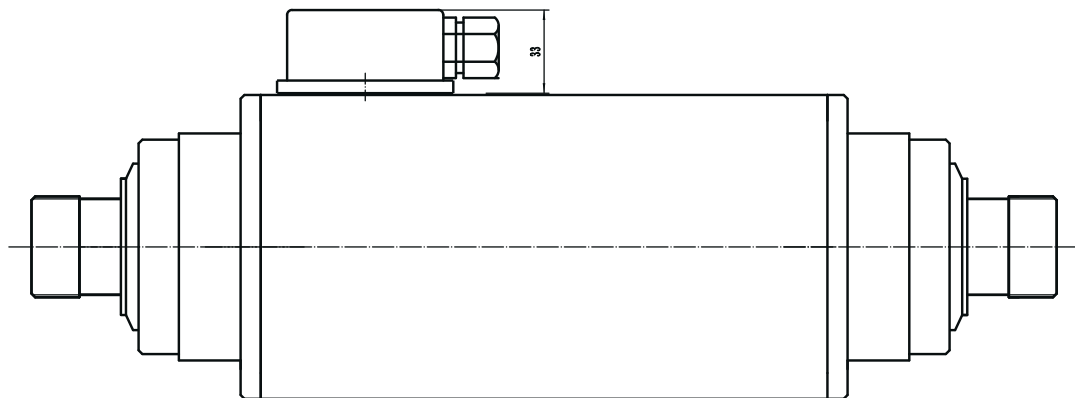

Parâmetros		
Tensão	V	380
Poder	KW	6.0
Corrente	A	12.6
Frequência	HZ	300
Rotação	rpm	18000
Torque	NM	3.18
Metodo de Resfriamento		AR

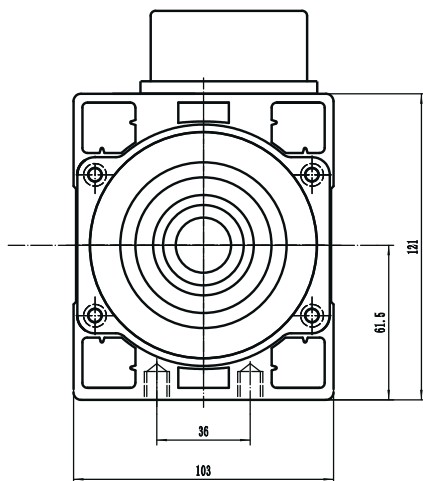
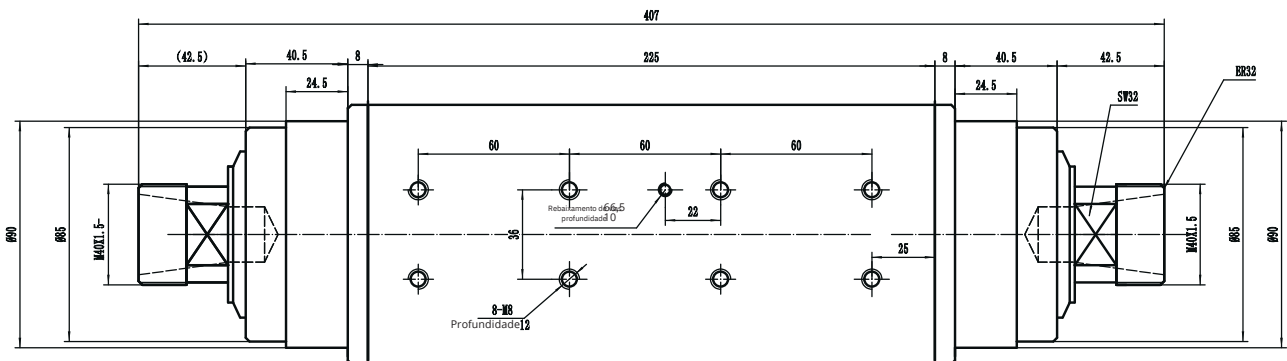
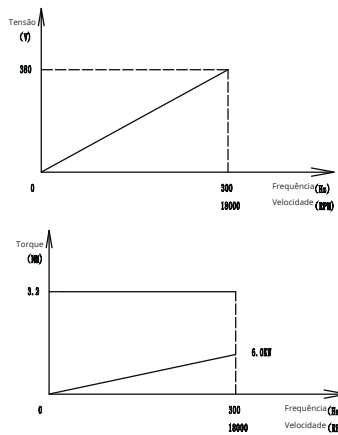

# PRADO

AUTOMAÇÃO INDUSTRIAL