



PRADO

AUTOMAÇÃO INDUSTRIAL

Guia de instalação do inversor HV610Z com função de parada orientada.



<https://pradoautomacaoindustrial.com.br>

email: vendas@pradoindustrial.com.br

(11) 5666-6461 / (11) 94242-8989 - WhatsApp

Table of contents

1. Standard wiring diagram.....	2
2. Brief parameter table.....	5
3. Parameter description.....	10
4. Application description.....	22
4.1. Pulse speed synchronization.....	22
4.1.1. Parameters related to pulse speed synchronization.....	22
4.1.2. Steps for synchronous debugging of pulse speed.....	22
4.2. Pulse position synchronization.....	23
4.2.1. Parameters related to pulse position synchronization.....	23
4.2.2. Steps for synchronous adjustment of pulse position.....	24
4.3. Analog gain switching.....	25
4.4. Indexing positioning.....	25

1. Standard wiring diagram

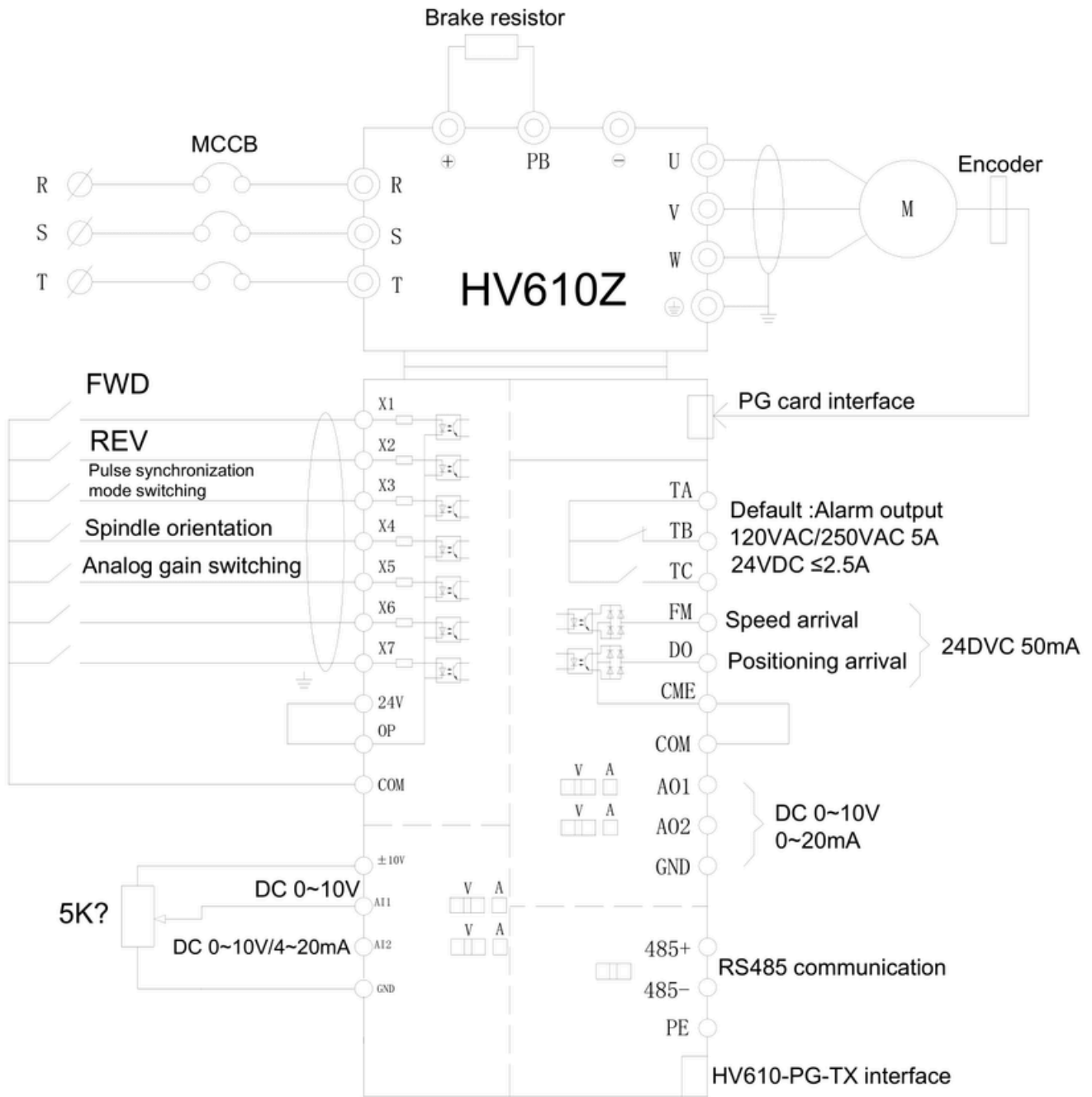

Quick Start guide for HV610Z variable frequency inverter – Spindle with Orientation

With the procedure provided below, the following functions will be realized.

- Forward and reverse running by enabling Digital Input 1 (X1) and Digital input 2 (X2) respectively. Running speed is set by analog input
- Orientation of the motor position and electrical clamping in the oriented position by setting Digital input 3 (X3) – typically used for ATC applications

This document is applicable when the encoder is installed directly on the spindle motor.

In this example, only one spindle orientation position is set.

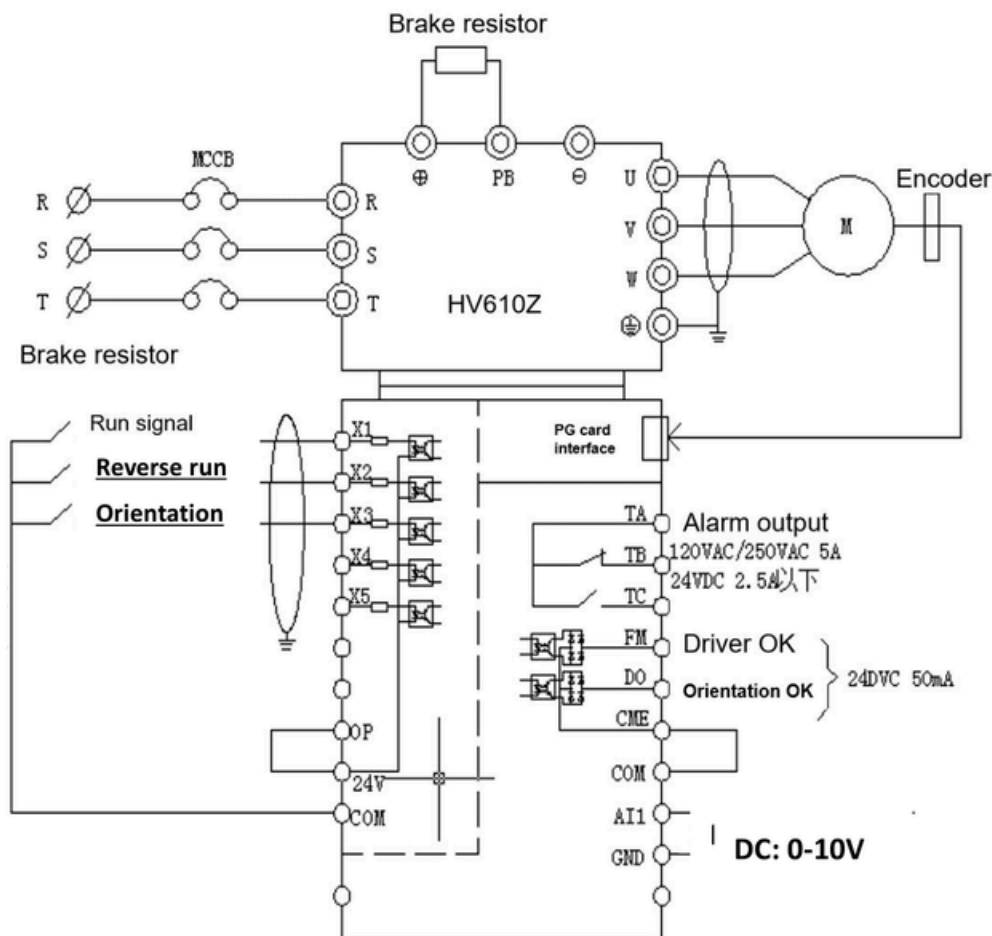

Diagram

Note. Before attempting any parameter settings, restore the factory default settings by setting FP-01=1. This parameter will automatically reset all the parameters apart from the motor parameters back to factory default, and then set itself back to 0.

1: Parameter setting.

Set the following parameters after restoring to factory default.

F0-01: 1 (FVC mode, close loop vector control)

F0-10: Maximum frequency (The frequency equivalent to a 100% analog input of 10v)

F0-12: Upper limit frequency (Maximum allowed running frequency)

Set the following to match the motor nameplate

F0-17: Acceleration time

- F0-18: Deceleration time
- F1-01: Motor rated power
- F1-02: Motor rated voltage
- F1-03: Motor rated current
- F1-04: Motor rated frequency
- F1-05: Motor rated speed
- F1-27: Encoder line number (note, the encoder must be installed on the motor)
- F1-28: 0, Encoder is ABZ incremental type, PG card is PG-DIF (other settings and PG cards are available)

2: Self-learning

The HV610z is capable of checking and setting the more detailed electrical characteristics of the motor automatically, to do this first set F0-02 = 0 (keyboard command)

Then set F1-37 = 2

The display will show "Tuning", press the start button to start the tuning cycle. Note, the motor should not be connected to the load.

It can happen that this cycle aborts with an error. In this case, re check the motor parameter settings above, verify the encoder wiring, and try again.

After successful learning, enter no-load operation and observe the operation status. (press the run button, the motor should accelerate and run at 50Hz). If the motor runs smoothly, enter the next step parameter setting. If the motor is not running smoothly, re-check the parameters before self-learning and repeat self-learning till motor runs smoothly.

3: Function parameters setting

- F0-02: 1 Terminal command channel
- F0-03: 2 Main frequency source AI1
- F4-00: 01 X1 is FWD run
- F4-01: 02 X2 is REV run
- F4-02: 66 X3 is Orientation
- F4-03: 09 Alarm reset
- F4-15: 10 AI1 maximum input
- F4-16: 100% AI2 maximum input corresponding setup
- F5-00: 1 FM as switch type output
- F5-01: 15 Drive OK
- F5-02: 2 Alarm output (Relay type output)
- F5-04: 21 Orientation OK
- A4-00: 0
- A4-01: 2 Angular orientation mode
- A4-20: --- Orientation Angle
- A4-21: 0 Angle source is A4-20

Note:

1. When set the orientation angle A4-20, please adjust the spindle to the target position, and check the value of u1-02, then store it in A4-20, then take this position as the target position when spindle orientation DI be active.
2. When F4-02=65, X2 is for orientation during spindle running, it is necessary to activate the X1& X3 at the same time in order to achieve orientation
3. When F4-02=66 (or 67), it is for orientation when spindle stop, it is only need to activate X3

2. Brief parameter table

Function code	Name	Setting range	Factory value	Change
F0 Basic function				
F0-03	X Selection of Main Frequency Source	0 ~ 9: Ignore 10: Pulse synchronization	0	★
F0-11	Upper frequency source	0 ~ 5: Ignore 6: Multi-speed instruction	0	★
F1 First motor parameters				
F1-32	Motor gear ratio numerator	1~65535	1	★
F1-33	Motor gear ratio denominator	1~65535	1	★
Group F2 First motor vector control parameters				
F2-11	Torque upper limit source under speed control (power generation)	Reference F2-09	0	★
F2-12	Torque upper limit set under speed control (power generation)	0.0%~200.0%	150.0%	☆
F2-17	Zero speed lock speed loop Kp	1~100	30	☆
F2-18	Zero speed lock speed loop Ti	0.001s~10.000s	0.500s	☆
F2-20	Zero speed lock speed loop switching frequency	0.00~F2-02	0.05Hz	★
Group F4 Input terminal				
F4-00	DI1 terminal function selection	50: Analog command gain switching	1	★
F4-01	DI2 terminal function selection	64: Pulse synchronization mode switching (pulse-speed	2	★
F4-02	DI3 terminal function selection	synchronization <-> pulse-position synchronization)	64	★
F4-03	DI4 terminal function selection	65: Positioning control switching (without command)	65	★
F4-04	DI5 terminal function selection	66: Positioning control switching (with forward rotation command)	50	★
F4-05	DI6 terminal function selection	67: Positioning control switching (with reverse command)		★
F4-06	DI7 terminal function selection	68: Multi-segment positioning length command 1	0	★
F4-07	DI8 terminal function selection	69: Multi-segment positioning length command 2	0	★
F4-08	DI9 terminal function selection	70: Multi-segment positioning length command 3	0	★
F4-09	DI10 terminal function selection		0	★

		74: Zero signal input 75: Re-positioning 76: Indexing positioning / incremental positioning mode switching		
Group F5 Output terminal				
F5-01	FMR output function selection	21: Positioning arrival	4	☆
F5-02	Control board relay function selection (T/A-T/B-T/C)	42: incremental positioning arrival (≥500ms high level) 43: Absolute positioning arrival (≥500ms high level)	2	☆
F5-03	Extension card relay output function selection (P/A-P/B-P/C)	44: Indexing positioning arrival (≥500ms high level)	0	☆
F5-04	DO1 output function selection		21	☆
F5-05	Expansion card DO2 output selection		0	☆
Group F8 Auxiliary function				
F8-54	Analog gain switching value	0.00%~100.00%	100.00%	☆
Group A3 Pulse synchronization				
A3-00	Pulse synchronization mode	0: Speed synchronization 1: Position synchronization	0	★
A3-01	Pulse mode selection	0: Pulse + direction 1: Two orthogonal pulses	1	★
A3-02	Quadrature pulse AB phase sequence	0: Forward 1: Reverse	0	★
A3-03	Acceleration time (position synchronization)	0.0~6500.0s	0.5s	☆
A3-04	Deceleration time (position synchronization)	0.0~6500.0s	0.5s	☆
A3-05	Feed-forward gain (position synchronization)	0.00~2.00	1.00	★
A3-06	Proportional gain 1 (position synchronization)	0.00~100.00	1.50	☆
A3-07	Electronic gear ratio numerator	1~30000	1	☆
A3-08	Electronic gear ratio denominator	1~30000	1	☆
A3-09	Pulse frequency filtering time	0.00~1.00s	0	☆
A3-10	Pulse frequency sampling coefficient	0~100	0	☆
A3-11	Proportional gain switching selection (Position synchronization)	0: Do not switch 1: Automatically switch according to deviation	1	☆
A3-12	Proportional gain 2 (position synchronization)	0.00~100.00	15.00	☆

A3-13	Proportional gain switching position deviation level 1 (position synchronization)	0~30000	5	☆
A3-14	Proportional gain switching position deviation level 2 (position synchronization)	0~30000	50	☆
A3-15	Acceleration compensation gain	0.00~10.00	0.00	☆
A3-16	Maximum pulse deviation	0~10000	500	☆
A3-17	Proportional gain 3	0.00~100.00	1.50	☆
A3-18	Minimum pulse deviation	0~1000	5	☆
A3-19	Pulse frequency filter time 2	0.00~10.00s	0.00s	☆
A3-20	Pulse frequency filtering time switching frequency	0.00Hz ~ Maximum frequency	0.00Hz	☆
A3-21	Detection value of excessive pulse deviation	0~2000	600	☆
A3-22	Detection time for excessive pulse deviation	0.00~10.00s	1.00s	☆
Group A4 positioning control				
A4-00	Effective positioning control	0: Invalid 1: Valid	0	☆
A4-01	Positioning mode selection	0: Incremental 1: Absolute 2: Indexing plate	2	★
A4-02	Indexing control encoder selection	0: Motor encoder 1: Special encoder for spindle positioning (not verified)	0	★
A4-03	Special encoder for spindle positioning Line number	1~65535	1024	★
A4-04	Spindle transmission ratio numerator (motor side gear)	1~10000	1	★
A4-05	Spindle transmission ratio denominator (load side gear)	1~10000	1	★
A4-06	Indexing origin selection	0: Position encoder Z signal 1: DI terminal	0	★
A4-07	Zero-point search direction	0: Forward 1: Reverse 2: Current direction 3: Opposite to the current direction	2	★
A4-08	Zero-point search frequency	0.00 ~ maximum frequency	5.00Hz	☆
A4-09	Positioning control start frequency	0.00 ~ maximum frequency	10.00Hz	☆

A4-10	Acceleration time (positioning control)	0.00~655.35s	3.00s	☆
A4-11	Deceleration time (positioning control)	0.00~655.35s	3.00s	☆
A4-12	Proportional gain 1 (positioning control)	0.01~100.00	1.00	☆
A4-13	Feed-forward gain (positioning control)	0.00~2.00	1.00	☆
A4-14	Positioning deviation range	0~1000	10	☆
A4-15	Positioning deviation limit	0~1000	2	☆
A4-16	Proportional gain switching selection	0: Do not switch 1: Automatically switch according to deviation	1	☆
A4-17	Proportional gain 2 (position control system)	0.00~100.00	10.00	☆
A4-18	Proportional gain switching pulse bias Poor 1	0~30000	5	☆
A4-19	Proportional gain switching pulse bias Poor 2	0~30000	50	☆
A4-20	Index position command	0~65535	0	☆
A4-21	Reserved	0~65535	0	☆
A4-22	Position control position instruction 1 low position	0~65535	0	☆
A4-23	Position control position instruction 1 high position	0~65535	0	☆
A4-24	Position control position instruction 2 low position	0~65535	0	☆
A4-25	Position control position instruction 2 high position	0~65535	0	☆
A4-26	Position control position instruction 3 low position	0~65535	0	☆
A4-27	Position control position instruction 3 high position	0~65535	0	☆
A4-28	Position control position instruction 4 low position	0~65535	0	☆
A4-29	Position control position instruction 4 high position	0~65535	0	☆
A4-30	Position control position instruction 5 low position	0~65535	0	☆

A4-31	Position control position instruction 5 high position	0~65535	0	☆
A4-32	Position control position instruction 6 low position	0~65535	0	☆
A4-33	Position control position instruction 6 high position	0~65535	0	☆
A4-34	Position control position instruction 7 low position	0~65535	0	☆
A4-35	Position control position instruction 7 high position	0~65535	0	☆
A4-36	Position control position instruction 8 low position	0~65535	0	☆
A4-37	Position control position instruction 8 high position	0~65535	0	☆
A4-38	Positioning control direction 1	0: Forward 1: Reverse Units: Positioning control command 1 direction Tens: Positioning control command 2 direction Hundreds: Positioning control command 3 directions Thousands: Positioning control command 4 directions Tens of thousands: Positioning control command 5 directions	00000	☆
A4-39	Positioning control direction 2	0: Forward 1: Reverse Units: Positioning control command 6 directions Tens: Positioning control command 7 direction Hundreds: Positioning control instruction 8 directions	000	☆
Group U1 Position control (spindle exact stop) monitoring parameters				
U1-00	Positioning control following error (after 4 times frequency)		1pulse	
U1-01	Pulse position following error (after 4 times frequency)		1pulse	
U1-02	Relative zero position (after 4 times frequency)		1pulse	
U1-03	External pulse given motor operating frequency (after calculation of transmission ratio)		0.01Hz	
U1-04	External pulse given frequency		0.01kHz	
U1-05	Position completion signal		1	

U1-06	Zero point retrieved	1
U1-07	Actual motor speed	1rpm/min
U1-08	Relative zero position high (after 4 times frequency)	1pulse
U1-09	Low position relative to the origin (after 4 octave)	1pulse
U1-10	The high number of pulse given number (after 4 times frequency)	1pulse
U1-11	Lowest number of pulse given number (after 4 times frequency)	1pulse
U1-12	External pulse given motor running frequency (before calculation of transmission ratio)	0.01Hz

3. Parameter description

F0-03	Main frequency source X selection	Default value	0
	Setting range	0 ~ 9: Ignore 10: Pulse synchronization	

Pulse synchronization means that the frequency source is given by the pulse input signal on the HV610-PG-TX card.

Pulse synchronization is divided into two methods, namely pulse speed synchronization and pulse position synchronization.

In the pulse speed synchronization mode, the target frequency (Hz) = the given pulse frequency * number of pole pairs * electronic gear numerator / (electronic gear denominator * number of encoder lines).

In the pulse position synchronization mode, in order to make the number of motor running pulses = the number of external reference pulses * electronic gear numerator / electronic gear denominator, the inverter automatically adjusts its operating frequency.

The numerator of the electronic gear ratio passes the function code (A3-07 setting), and the denominator of the electronic gear ratio passes the function code (A3-08 setting).

F1-32	Motor gear ratio numerator	Default value	1
	Setting range	1~65535	
F1-33	Motor gear ratio denominator	Default value	1
	Setting range	1~65535	

When the encoder is not directly installed on the motor shaft, there may be a transmission ratio between the encoder and the motor shaft, the conversion relationship is as follows:

Actual motor speed = encoder speed * motor gear ratio numerator / motor gear ratio denominator

F2-11	Torque upper limit source (power generation) in speed control mode	Default value	0
	Setting range	0: F2-10 1: AI1 2: AI2 3: AI3 4: PULSE setting 5: Communication settings	
F2-12	Digital setting of torque upper limit in speed control mode (power generation)	Default value	150.0%
	Setting range	0.0%~200.0%	

In the speed control mode, the maximum output torque of the servo drive in the power generation state is controlled by the torque upper limit source.

F2-11 set source used to select the torque upper limit, when set by analog , pulse, communication, the corresponding set 100% corresponding F2-12, and the F2-10 100% is the servo driver rated torque.

F2-00	Speed loop proportional gain 1	Default value	40
	Setting range	1~200	
F2-01	Speed loop integration time 1	Default value	0.500s
	Setting range	0.001s~9.000s	
F2-02	Switching frequency 1	Default value	5.00Hz
	Setting range	0.00~F2-05	
F2-03	Speed loop proportional gain 2	Default value	30
	Setting range	1~200	
F2-04	Speed loop integration time 2	Default value	0.500s
	Setting range	0.001s~9.000s	
F2-05	Switching frequency 2	Default value	10.00Hz
	Setting range	F2-02 ~ Maximum output frequency	
F2-17	Zero speed locking speed loop Kp	Default value	30
	Setting range	1~100	

F2-18	Zero speed lock speed loop Ki	Default value	0.500
	Setting range	0.001~10.000	
F2-20	Zero speed locked speed loop switching frequency	Default value	0.05Hz
	Setting range	0.00~F2-02	

When the servo drive runs at different frequencies, you can select different speed loop PI parameters.

- When the running frequency is less than the zero-speed lock switching frequency (F2-20), the speed loop PI adjustment parameter is the zero-speed lock speed loop PI parameter (F2-17/F2-18).
- When the operating frequency is greater than the zero-speed locking switching frequency (F2-20) and less than the switching frequency 1 (F2-02), the speed loop PI adjustment parameters are the zero-speed locking speed loop PI parameters (F2-17/F2-18) and speed Ring PI parameter 1 (F2-00/F2-01) is switched linearly.
- When the operating frequency is greater than the switching frequency 1 (F2-02) and less than the switching frequency 2 (F2-05), the speed change PI adjustment parameters are speed loop PI parameter 1 (F2-00/F2-01) and speed loop PID parameter 2 (F2-03/F2-04) Linear switching
- When the operating frequency is greater than the switching frequency 2 (F2-05), the speed loop PI adjustment parameter is the speed loop PID parameter 2 (F2-03/F2-04)

As shown in Figure 6-2:

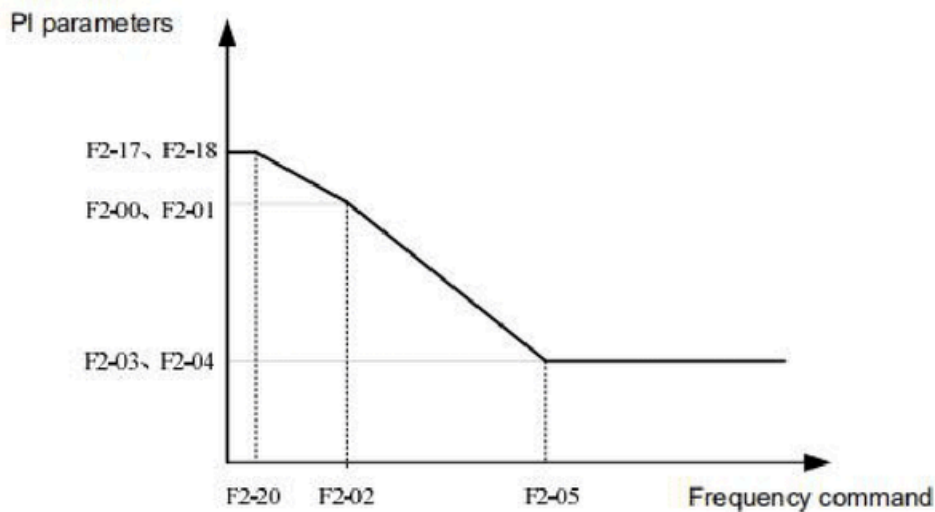

Figure 6-2 Schematic diagram of PI parameters

By setting the proportional coefficient and integration time of the speed regulator, the speed dynamic response characteristics of the vector control can be adjusted.

Increasing the proportional gain and reducing the integration time can speed up the dynamic response of the speed loop. But too large proportional gain or too small integration time may cause the system to oscillate. The recommended adjustment method is:

If the default parameters cannot meet the requirements, fine-tune on the basis of default parameters, first increase the proportional gain to ensure that the system does not oscillate; then reduce the integration time to make the system have faster response characteristics, and the overshoot is smaller.

Note: Improper PI parameter setting may cause excessive speed overshoot. An over-voltage fault may even occur when the overshoot falls.

F4-00	DI1 terminal function selection	Default value	1 (Forward running)
F4-01	DI2 terminal function selection	Default value	2 (Reverse running)
F4-02	DI3 terminal function selection	Default value	64 (Pulse synchronization mode switching)
F4-03	DI4 terminal function selection	Default value	65 (Positioning control switching)
F4-04	DI5 terminal function selection	Default value	50 (Analog gain switching)
F4-05	DI6 terminal function selection	Default value	0
F4-06	DI7 terminal function selection	Default value	0
F4-07	DI8 terminal function selection	Default value	0
F4-08	DI9 terminal function selection	Default value	0
F4-09	DI10 terminal function selection	Default value	0

These parameters are used to set the functions of the digital multi-function DI terminals. The functions that can be selected are shown in the following table:

Set value	Function	Explanation
50	Analog command gain switching	Corresponding function code "F8-54 (analog gain switching value)" description.
64	Pulse synchronization mode switching	To realize the switch between pulse position synchronization and pulse speed synchronization, corresponding function code A3-00
65	Positioning control switching (without command)	When this terminal function is valid and the run command is valid, the inverter enters the positioning operation mode
66	Positioning control switching (with forward rotation command)	When this terminal function is valid, the inverter runs forward and enters the positioning operation mode
67	Positioning control switching (with reverse command)	When this terminal function is valid, the inverter runs in reverse and enters the positioning operation mode
68	Multi-segment positioning length command 1	The 8-state length command can be set through the 8 states of these three terminals. For details, see the description of A4-20 ~ A4-35.
69	Multi-segment positioning length command 2	
70	Multi-segment positioning length command 3	
74	Terminal zero signal input	When the indexing positioning zero signal is a DI terminal, the DI5 function needs to be set to 74
75	Re-positioning	During positioning operation, a new positioning signal is generated when the rising edge of this signal is valid
76	Indexing / incremental positioning mode switching	This terminal function is used to switch between indexing and incremental positioning

F5-01	FMR function selection (open collector output terminal)	Default value	4 (Speed arrival)
F5-02	Relay output function selection (T / A-T / B-T / C)	Default value	2
F5-03	Extension card relay output function selection (P / A-P / B-P / C)	Default value	0
F5-04	DO1 output function selection (open collector output terminal)	Default value	21 (arrival at quasi-stop position / arrival at positioning position)
F5-05	Expansion card DO2 output function selection	Default value	0

The above 5 function codes are used to select the functions of 5 digital outputs, among which T/A-T/B-T/C and P/A-P/B-P/C are the relays on the control board and the expansion card respectively.

The function descriptions of the multi-function output terminals are as follows:

Set value	Function	Explanation
21	Positioning arrival	When the positioning operation status is reached and the target position is reached, the ON signal is output, see the description of parameter A4-14
42	Incremental positioning arrival	When incremental positioning arrives, output a 500ms high level
43	Absolute positioning arrival	When the absolute positioning arrives, output a 500ms high level
44	Indexing arrival	When indexing arrives, output a 500ms high level

F8-54	Analog gain switching value	Default value	100.00%
	Set range	0.00%~1000.0%	

This parameter is used to set when the frequency source is analog voltage reference, switch the analog input 100.0% of all corresponding frequencies through DI function. When DI function 50: Analog command gain switching is invalid, the analog input corresponding setting of 100.0% indicates the maximum frequency (F0-10). When DI function 50: Analog command gain switching is valid, the corresponding setting of analog input 100.0% indicates the maximum frequency * F8-54

A3-00	Pulse synchronization mode	Default value	0
	Set range	0: Pulse speed synchronization 1: Pulse position synchronization	

To select the pulse synchronization mode, this parameter needs to be used in conjunction with DI function 64: Pulse synchronization mode switching.

When the DI function pulse synchronization mode is valid, the pulse synchronization mode is determined by the setting value of A3-00.

When the DI function pulse synchronization mode is invalid, the pulse synchronization mode is to reverse the set value of A3-00

A3-01	Pulse mode selection	Default value	0
	Set range	0: Pulse + Direction 1: Two orthogonal pulses	
A3-02	Orthogonal pulse AB phase sequence	Default value	0
	Set range	0: Forward 1: Reverse	

Set pulse signal input mode

➤ Pulse + Direction

This method only supports differential signal input. The hardware wiring needs to connect the differential direction signal to the positioning card A+ / A-, and the pulse signal to B+ / B-. At the same time, the positioning expansion card jumper needs to be processed. .

➤ Two orthogonal pulses

This method only supports differential signal input. Connect the differential signal to A+ / A- / B+ / B-. At the same time, the positioning expansion card jumper needs to be processed. The signal is internally multiplied by 4 times.

A3-03	Acceleration time (position synchronization)	Default value	0.0s
	Set range	0.0~6500.0s	
A3-04	Deceleration time (position synchronization)	Default value	0.0s
	Set range	0.0~6500.0s	

In the pulse speed synchronized mode, it use the inverter's standard acceleration and deceleration time (acceleration and deceleration time 1/2/3/4)

In the pulse position synchronized mode, use A3-03 and A3-04 as the acceleration and deceleration time

A3-06	Proportional gain 1 (position synchronization)	Default value	1.50
	Set range	0.00~100.00	
A3-11	Proportional gain switching selection (position synchronization)	Default value	1
	Set range	0: Do not switch 1: Automatically switch according to deviation	
A3-12	Proportional gain 2 (position synchronization)	Default value	15.00
	Set range	0.00~100.00	
A3-13	Proportional gain switching position deviation level 1 (position synchronization)	Default value	5
	Set range	0~30000	
A3-14	Proportional gain switching position deviation level 2 (position synchronization)	Default value	50
	Set range	0~30000	
A3-17	Proportional gain 3 (position synchronization)	Default value	1.50
	Set range	0.00~100.00	

The parameters in this column are used to set the proportional gain when use pulse position synchronized mode.

➤ When the pulse sampling frequency is 0:

The proportional gain of the pulse position synchronization position loop is the set value of A3-06.

➤ When the pulse sampling frequency is not 0:

If it is set to 0: without switching, the proportional gain of the pulse position synchronization position loop is the set value of A3-06.

If it is set to 1: When switching automatically according to the deviation, the proportional gain value of the pulse position synchronization position loop is the linear interpolation value between A3-06 and A3-12.

Observe U1-01: The pulse position follows the error value to correct the proportional gain value

A3-07	Electronic gear ratio numerator	Default value	1
	Set range	0~30000	
A3-08	Electronic gear ratio denominator	Default value	1
	Set range	0~30000	

Set the electronic gear ratio during pulse synchronization.

In the pulse speed synchronized mode, the actual target frequency of the inverter = sampling frequency * A3-07 / A3-08

In the pulse position synchronized mode, the actual target pulse number of the inverter = sampling pulse number * A3-07 / A3-08

A3-09	Pulse sampling filter time 1	Default value	0
	Set range	0.00~1.00s	
A3-19	Pulse sampling filter time 2	Default value	0
	Set range	0.00~1.00s	
A3-20	Pulse sampling filter time switching frequency	Default value	0.00Hz
	Set range	0.00 ~ maximum frequency	

Set the pulse sampling filter time.

When the pulse frequency is greater than or equal to the A3-20 setting value, use A3-09 as the pulse sampling filter time

When the pulse frequency is less than the set value of A3-20, use A3-19 as the pulse frequency sampling filter time

A3-15	Acceleration and deceleration compensation gain (position synchronization)	Default value	0.00
	Set range	0.00~10.00	

When the external frequency signal is in the acceleration and deceleration phase, the proportional gain may not be adjusted in place. At this time, acceleration and deceleration compensation gain can be added to make the deviation during acceleration and deceleration smaller.

A3-16	Maximum pulse deviation (position synchronization)	Default value	500
	Set range	0~10000	

When setting pulse position synchronization, the maximum deviation in position loop adjustment.

When the deviation exceeds A3-16, use A3-16 as the calculated value of the deviation in the position loop to prevent the deviation from being too large and causing the position loop adjustment to be too strong.

A3-19	Minimum pulse deviation (position synchronization)	Default value	5
	Set range	0~10000	

When setting pulse synchronization, the minimum deviation in position loop adjustment.

When the deviation is less than A3-19, use 0 as the calculated value of the position loop deviation, the position loop stops adjusting to prevent the motor from shaking

A3-20	Detection value of excessive pulse deviation (position synchronization)	Default value	600
	Set range	0~2000	
A3-21	Detection time of excessive pulse deviation (position synchronization)	Default value	1.00s
	Set range	0.00~10.00	

In position synchronization, when the pulse deviation exceeds the setting value of A3-20 and the duration exceeds the setting time of A3-21, the inverter fault alarm 55: The pulse deviation is too large

A4-00	Effective positioning control	Default value	0
	Set range	0: invalid 1: effective	

Set whether the positioning control is valid.

In addition to setting parameter A4-00, the positioning function can be effectively set through the terminal function, as follows

DI value	Function	Description
65	Positioning control switching (without command)	When the terminal function is valid and the run command is valid, the inverter enters the positioning control running state
66	Positioning control switching (with forward rotation command)	When the terminal function is valid and the run command is the terminal, the inverter enters the positioning control running state (forward running)
67	Positioning control switching (with reverse command)	When the terminal function is valid and the running command is the terminal, the inverter enters the positioning control running state (reverse running)

A4-01	Positioning mode selection	Default value	2
	Set range	0: incremental 1: Absolute 2: Indexing plate	

This parameter is used to set the positioning mode. It currently includes three positioning modes:

0: Incremental type, that is, a fixed set pulse is run every time

1: Absolute, each operation is equivalent to a mechanical fixed origin position setting pulse

2: Indexing dial, suitable for indexing positioning occasions, each positioning to the position relative to the zero pulse reference

When the DI terminal function orientation positioning / indexing positioning switch is valid, the positioning method will change as follows:

If A4-01 is set to incremental type, the positioning mode is switched to the index plate

If A4-01 is set as an index plate, the positioning mode is switched to incremental

A4-06	Selection of zero point source for indexing positioning	Default value	0
	Set range	0: Position encoder Z signal 1: DI terminal	

This parameter is used to set the zero point source during indexing positioning. At present, it supports motor encoder Z signal or high-speed DI terminal as positioning zero point.

When the selection is 1: DI terminal, the DI5 function must also be set to 74: terminal zero input

A4-07	Zero-point search direction	Default value	2
	Set range	0: Forward 1: Reverse 2: Current direction 3: Opposite to the current direction	
A4-08	Zero search frequency	Default value	5.00Hz
	Set range	0.00 ~ maximum frequency	

When the inverter receives the indexing and positioning command in the stopped state, it will first retrieve the home point and then start the indexing and positioning.

This parameter is used to set parameters related to origin retrieval

A4-09	Positioning control start frequency	Default value	10.00Hz
	Set range	0.00 ~ maximum frequency	

When the inverter receives the indexing positioning command in the running state, it will first decelerate to the starting frequency of the positioning control, and then start the indexing positioning.

This parameter is used to set the initial frequency value of positioning control.

A4-10	Acceleration time (positioning control)	Default value	3.00s
	Set range	0.00~655.35s	
A4-11	Deceleration time (positioning control)	Default value	3.00s
	Set range	0.00~655.35s	

Set the frequency acceleration and deceleration time during positioning control.

A4-14	Positioning deviation range	Default value	10
	Set range	0~1000	

This parameter is used to set the positioning completion judgment standard.

When the difference between the actual operating position and the set position is less than or equal to the set value of A4-14, the inverter outputs a positioning complete signal. The positioning completion signal can be obtained through DO function 21: positioning completion and parameter U1-05: positioning completion signal.

A4-15	Positioning deviation limit	Default value	2
	Set range	0~1000	

When the positioning completion signal is valid, if the current pulse deviation is less than or equal to the A4-15 setting value, the position loop will no longer be adjusted.

Setting this value too small may cause the position loop to jitter when it arrives periodically.

A4-12	Proportional gain 1 (positioning control)	Default value	1.00
	Set range	0.01~100.00	
A4-16		Default value	1
	Set range	0: Do not switch 1: Automatically switch according to deviation	
A4-17		Default value	10.00
	Set range	0.00~100.00	
A4-18		Default value	5
	Set range	0~30000	
A4-19		Default value	50
	Set range	0~30000	

The parameters in this column are used to set the proportional gain value during positioning control.

When A4-16 is set to 0: no switching, the proportional gain of the positioning control position loop is the set value of A4-12.

When A3-16 is set to 1: automatically switch according to the deviation, the proportional gain of the positioning control position loop is the linear interpolation value between A3-12 and A3-17.

In actual operation, correct the proportional gain value by observing U1-00: Positioning control following error value.

A4-20	Indexing positioning command	Default value	0
	Set range	0~65535	

Set the indexing target position.

After adjusting the spindle to the target position, check the value of U1-02 and store the value in A4-20. Then each time the positioning is indexed, the position is used as the target position.

A4-22	Position control position instruction 2 low position	Default value	0
	Set range	0~65535	
A4-23	Position control position instruction 2 high position	Default value	0
	Set range	0~65535	
A4-24	Position control position instruction 3 low position	Default value	0
	Set range	0~65535	

A4-25	Position control position instruction 3 high position	Default value	0
	Set range	0~65535	
A4-26	Position control position instruction 4 low position	Default value	0
	Set range	0~65535	
A4-27	Position control position instruction 4 high position	Default value	0
	Set range	0~65535	
A4-28	Position control position instruction 5 low position	Default value	0
	Set range	0~65535	
A4-29	Position control position instruction 5 high position	Default value	0
	Set range	0~65535	
A4-30	Position control position instruction 6 low position	Default value	0
	Set range	0~65535	
A4-31	Position control position instruction 6 high position	Default value	0
	Set range	0~65535	
A4-32	Position control position instruction 7 low position	Default value	0
	Set range	0~65535	
A4-33	Position control position instruction 7 high position	Default value	0
	Set range	0~65535	
A4-34	Position control position instruction 8 low position	Default value	0
	Set range	0~65535	
A4-35	Position control position instruction 8 high position	Default value	0
	Set range	0~65535	
A4-36	Position control position instruction 8 low position	Default value	0
	Set range	0~65535	
A4-37	Position control position instruction 8 high position	Default value	0
	Set range	0~65535	
A4-38	Positioning control position command direction 1	Default value	0000
	Set range	0: Forward 1: Reverse Units: position command 1 direction	

		Tens: position command 2 direction Hundreds: position command 3 directions Thousands: Position command 4 directions Tens of thousands: position command 5 directions	
A4-39	Positioning control position command direction 2	Default value	000
	Set range	0: forward 1: reverse Units: Position command 6 directions Tens: position command 7 direction Hundreds: position command 8 directions	

Set 8-segment length command direction.

The HV610Z supports a total of 8 positioning length selections, which can be selected through DI terminal functions 68, 69, and 70, as shown in the following table:

DI functional status			Position command selection (4 times frequency)	Position command value
70	69	68		
OFF	OFF	OFF	Position command 1	$(A4-23)*65536+(A4-22)$
OFF	OFF	ON	Position command 2	$(A4-25)*65536+(A4-24)$
OFF	ON	OFF	Position command 3	$(A4-27)*65536+(A4-26)$
OFF	ON	ON	Position command 4	$(A4-29)*65536+(A4-28)$
ON	OFF	OFF	Position command 5	$(A4-31)*65536+(A4-30)$
ON	OFF	ON	Position command 6	$(A4-33)*65536+(A4-32)$
ON	ON	OFF	Position command 7	$(A4-35)*65536+(A4-34)$
ON	ON	ON	Position command 8	$(A4-37)*65536+(A4-36)$

4. Application description

4.1. Pulse speed synchronization

4.1.1. Parameters related to pulse speed synchronization

Function code	Function parameter	Set value
F0-03	Main frequency source X selection	10: Pulse synchronization
A3-00	Pulse synchronization mode	0: speed synchronization 1: Position synchronization
A3-01	Pulse mode selection	0: pulse + direction 1: Two orthogonal pulses
A3-02	Quadrature pulse AB phase sequence	0: forward 1: reverse
A3-07	Electronic gear ratio numerator	1 ~ 30000
A3-08	Electronic gear ratio denominator	1 ~ 30000
A3-09	Pulse frequency filtering time	0.00 ~ 1.00s
A3-19	Pulse frequency filter time 2	0.00 ~ 10.00s
A3-20	Pulse frequency filtering time switching frequency	0.00Hz ~ Maximum frequency
F4-00 ~ F4-09	DI1~DI10 terminal function selection	64: Pulse synchronization mode switching (pulse speed synchronization <-> pulse position synchronization)

4.1.2. Steps for synchronous debugging of pulse speed

Pulse synchronization is mainly divided into pulse speed synchronization and pulse position synchronization. Pulse speed synchronization means that the inverter samples the pulse frequency signal on the expansion card and converts it into a frequency command. The inverter runs at this frequency as the target frequency. To use the pulse synchronization function, you need to use the expansion card HV610-PG-TX to sample the pulse signal.

Steps	Setting type	Parameter	Description
1	Frequency source is pulse synchronization	F0-03 = 10	
2	Pulse synchronization mode is pulse speed synchronization	A3-00 = 0	Through DI terminal function 64, you can switch the pulse synchronization mode set in A3-00
3	Pulse signal type	A3-01 = Actual A3-02 = Actual	Set A3-01 and A3-02 parameter values according to the actual signal type

4	Electronic gear ratio	A3-07 =Actual A3-08 =Actual	Set A3-07 and A3-08 parameter values according to the actual signal type
5	Pulse filter time	A3-09 =Actual A3-19 =Actual A3-20 =Actual	Observe U1-03 (external pulse given operating frequency), adjust the pulse filter time

4.2. Pulse position synchronization

4.2.1. Parameters related to pulse position synchronization

Function code	Function parameter	Set value
F0-03	Main frequency source X selection	10: Pulse synchronization
A3-00	Pulse synchronization mode	0: speed synchronization 1: Position synchronization
A3-01	Pulse mode selection	0: pulse + direction 1: Two orthogonal pulses
A3-02	Quadrature pulse AB phase sequence	0: forward 1: reverse
A3-03	Acceleration time (position synchronization)	0.0~6500.0s
A3-04	Deceleration time (position synchronization)	0.0~6500.0s
A3-06	Proportional gain 1 (position synchronization)	0.00~100.00
A3-07	Electronic gear ratio numerator	1~30000
A3-08	Electronic gear ratio denominator	1~30000
A3-09	Pulse frequency filtering time	0.00~1.00s
A3-11	Proportional gain switching selection (position synchronization)	0: Do not switch 1: Automatically switch according to deviation
A3-12	Proportional gain 2 (position synchronization)	0.00~100.00
A3-13	Proportional gain switching position deviation level 1 (position synchronization)	0~30000
A3-14	Proportional gain switching position deviation level 2 (position synchronization)	0~30000
A3-15	Acceleration compensation gain	0.00~10.00
A3-16	Maximum pulse deviation	0~10000
A3-17	Proportional gain 3	0.00~100.00
A3-18	Minimum pulse deviation	0~1000
A3-19	Pulse frequency filter time 2	0.00~10.00s
A3-20	Pulse frequency filtering time switching frequency	0.00Hz ~ Maximum frequency

A3-21	Detection value of excessive pulse deviation	0~2000
A3-22	Detection time for excessive pulse deviation	0.00~10.00s
F4-00 ~ F4-09	DI1 ~ DI10 terminal function selection	64: Pulse synchronization mode switching (pulse speed synchronization <-> pulse position synchronization)

4.2.2. Steps for synchronous adjustment of pulse position

Pulse synchronization is mainly divided into pulse speed synchronization and pulse position synchronization. Pulse position synchronization means the inverter samples the pulse number signal on the expansion card and makes the actual running pulse number of the motor consistent with the sampled pulse number in real time. To use the pulse synchronization function, you need to use the card HV610-PG-TX to sample the pulse signal.

Steps	Setting type	Parameter	Description
1	Frequency source is pulse synchronization	F0-03 = 10	
2	Pulse synchronization mode is pulse speed synchronization	A3-00 = 0	Through DI terminal function 64, you can switch the pulse synchronization mode set in A3-00
3	Pulse signal type	A3-01 = Actual	Set A3-01 and A3-02 parameter values according to the actual signal type
4	Electronic gear ratio	A3-07 =Actual A3-08 =Actual	Set A3-07 and A3-08 parameter values according to the actual signal type
5	Pulse filter time	A3-09 =Actual A3-19 =Actual A3-20 =Actual	Observe U1-03 (external pulse given operating frequency), adjust the pulse filter time
6	Position synchronization acceleration and deceleration time	A3-03 =Actual A3-04 =Actual	
7	Proportional gain	A3-06 = Actual A3-11 = Actual A3-12 = Actual A3-13 = Actual A3-14 = Actual	Observe the value of U1-01 (pulse position following deviation) and correct the proportional gain The proportional gain can be set to switch linearly according to the deviation (A3-11 = 1)
8	Pulse deviation limit	A3-16 =Actual A3-18=Actual	When the pulse deviation exceeds A3-16, the position loop takes the A3-16 setting value as the adjustment coefficient When the pulse deviation is less than A3-18, the position loop stops adjusting

9	Pulse deviation protection	A3-21=Actual A3-22=Actual	When the pulse deviation exceeds A3-21 and the duration exceeds the setting of A3-22, the inverter fails Alarm 55: Excessive pulse deviation
---	----------------------------	------------------------------	---

4.3. Analog gain switching

When using the analog signal as the frequency reference command, you can use the DI terminal function 50: Analog command gain switching to achieve the actual frequency corresponding to 100% of the analog reference
When DI terminal function 50 is invalid, the frequency reference value = analog reference percentage * F0-10
When DI terminal function 50 is valid, the frequency reference value = analog reference percentage * F0-10 * F8-54

4.4. Indexing positioning

HV610Z currently supports indexing positioning in 4 modes, as follows:

Mode 1: The transmission ratio of the motor to the spindle is 1: 1, and the encoder is installed on the spindle or the motor.

Parameter Type	Parameter settings
Motor encoder information	F1-27 = Number of motor encoder lines F1-32 = 1 F1-33 = 1
Indexing positioning parameters	A4-02 = 0 A4-06 = 0

Mode 2: The transmission ratio between the motor and the spindle is not 1: 1, an encoder is installed on the motor side, and a photoelectric switch signal is connected to the spindle.

Parameter Type	Parameter settings
Motor encoder information	F1-27 = Number of motor encoder lines F1-32 = 1 F1-33 = 1
Photoelectric switch parameters	F4-04 = 74 (Need to use DI5 as photoelectric switch signal input)
Indexing positioning parameters	A4-02 = 0 A4-04 = numerator of main shaft transmission ratio A4-05 = Spindle transmission ratio denominator (Spindle speed = encoder speed * A4-05 / A4-04) A4-06 = 1

Mode 3: The transmission ratio between the motor and the spindle is not 1: 1. No encoder is installed on the motor side, and an encoder is installed on the spindle side.

Parameter Type	Parameter settings
Motor encoder information	F1-27 = Number of motor encoder lines F1-32 = Motor gear ratio numerator F1-33 = Motor gear ratio denominator (Motor speed = encoder speed * F1-33 / F1-32)
Indexing positioning parameters	A4-02 = 0 A4-06 = 0

Mode 4: The transmission ratio between the motor and the spindle is not 1: 1, and the encoder is installed on the motor side and the encoder is installed on the spindle side.

Parameter Type	Parameter settings
Motor encoder information	F1-27 = Number of motor encoder lines F1-32 = 1 F1-33 = 1
Indexing positioning parameters	A4-02 = 1 A4-03 = Spindle encoder line number A4-04 = numerator of spindle transmission ratio A4-05 = Spindle transmission ratio denominator (Spindle speed = motor speed * A4-05 / A4-04) A4-06 = 0