



PRADO

AUTOMAÇÃO INDUSTRIAL

Quick Start guide for HV610Z variable frequency inverter – Spindle with Orientation

With the procedure provided below, the following functions will be realized.

- Forward and reverse running by enabling Digital Input 1 (X1) and Digital input 2 (X2) respectively. Running speed is set by analog input
- Orientation of the motor position and electrical clamping in the oriented position by setting Digital input 3 (X3) – typically used for ATC applications

This document is applicable when the encoder is installed directly on the spindle motor.

In this example, only one spindle orientation position is set.

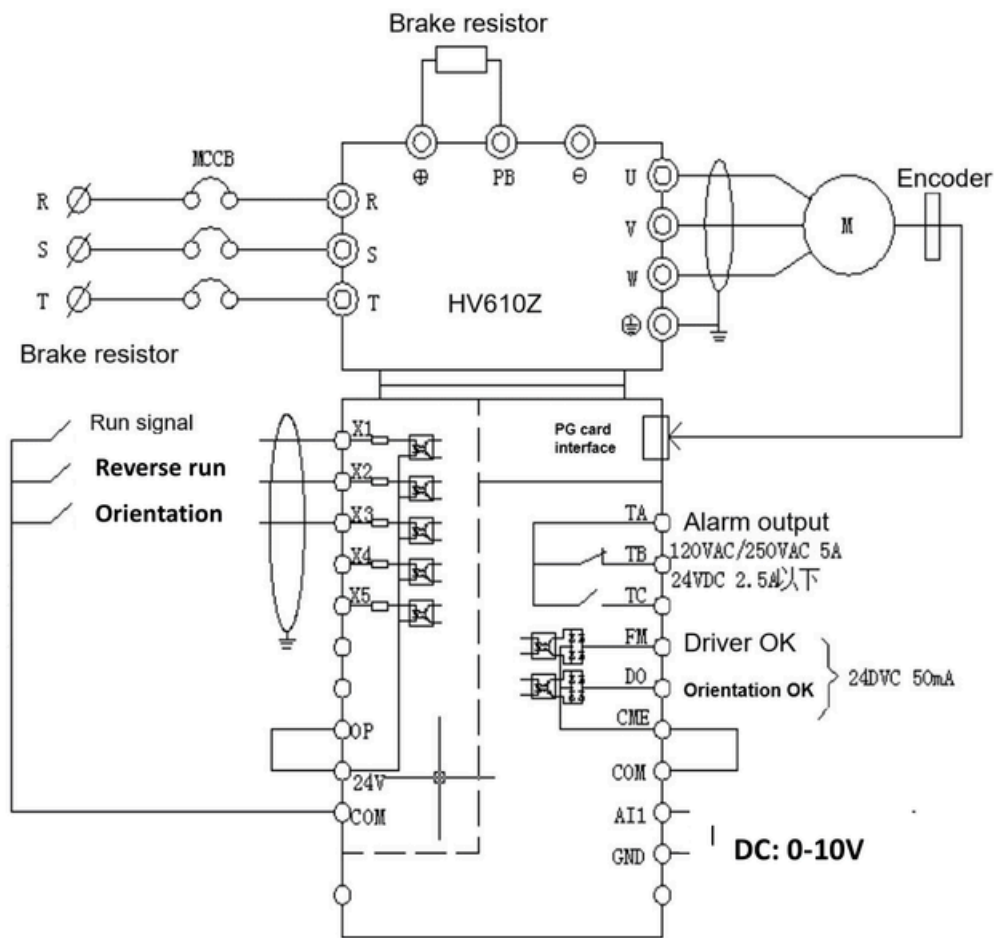

Diagram

Note. Before attempting any parameter settings, restore the factory default settings by setting FP-01=1

This parameter will automatically reset all the parameters apart from the motor parameters back to factory default, and then set itself back to 0.

1: Parameter setting.

Set the following parameters after restoring to factory default.

F0-01: 1 (FVC mode, close loop vector control)

F0-10: Maximum frequency (The frequency equivalent to a 100% analog input of 10v)

F0-12: Upper limit frequency (Maximum allowed running frequency)

Set the following to match the motor nameplate

F0-17: Acceleration time

F0-18: Deceleration time

F1-01: Motor rated power

F1-02: Motor rated voltage

F1-03: Motor rated current

F1-04: Motor rated frequency

F1-05: Motor rated speed

F1-27: Encoder line number (note, the encoder must be installed on the motor)

F1-28: 0, Encoder is ABZ incremental type, PG card is PG-DIF (other settings and PG cards are available)

2: Self-learning

The HV610z is capable of checking and setting the more detailed electrical characteristics of the motor automatically, to do this first set F0-02 = 0 (keyboard command)

Then set F1-37 = 2

The display will show "Tuning", press the start button to start the tuning cycle. Note, the motor should not be connected to the load.

It can happen that this cycle aborts with an error. In this case, re check the motor parameter settings above, verify the encoder wiring, and try again.

After successful learning, enter no-load operation and observe the operation status. (press the run button, the motor should accelerate and run at 50Hz). If the motor runs smoothly, enter the next step parameter setting. If the motor is not running smoothly, re-check the parameters before self-learning and repeat self-learning till motor runs smoothly.

3: Function parameters setting

F0-02: 1 Terminal command channel

F0-03: 2 Main frequency sourceA11

F4-00: 01 X1 is FWD run

F4-01: 02 X2 is REV run

F4-02: 66 X3 is Orientation

F4-03: 09 Alarm reset

F4-15:	10	AI1 maximum input
F4-16:	100%	AI2 maximum input corresponding setup
F5-00:	1	FM as switch type output
F5-01:	15	Drive OK
F5-02:	2	Alarm output (Relay type output)
F5-04:	21	Orientation OK
A4-00:	0	
A4-01:	2	Angular orientation mode
A4-20:	---	Orientation Angle
A4-21:	0	Angle source is A4-20

Note:

1. When set the orientation angle A4-20, please adjust the spindle to the target position, and check the value of u1-02, then store it in A4-20, then take this position as the target position when spindle orientation DI be active.
2. When F4-02=65, X2 is for orientation during spindle running, it is necessary to activate the X1& X3 at the same time in order to achieve orientation
3. When F4-02=66 (or 67), it is for orientation when spindle stop, it is only need to activate X3