

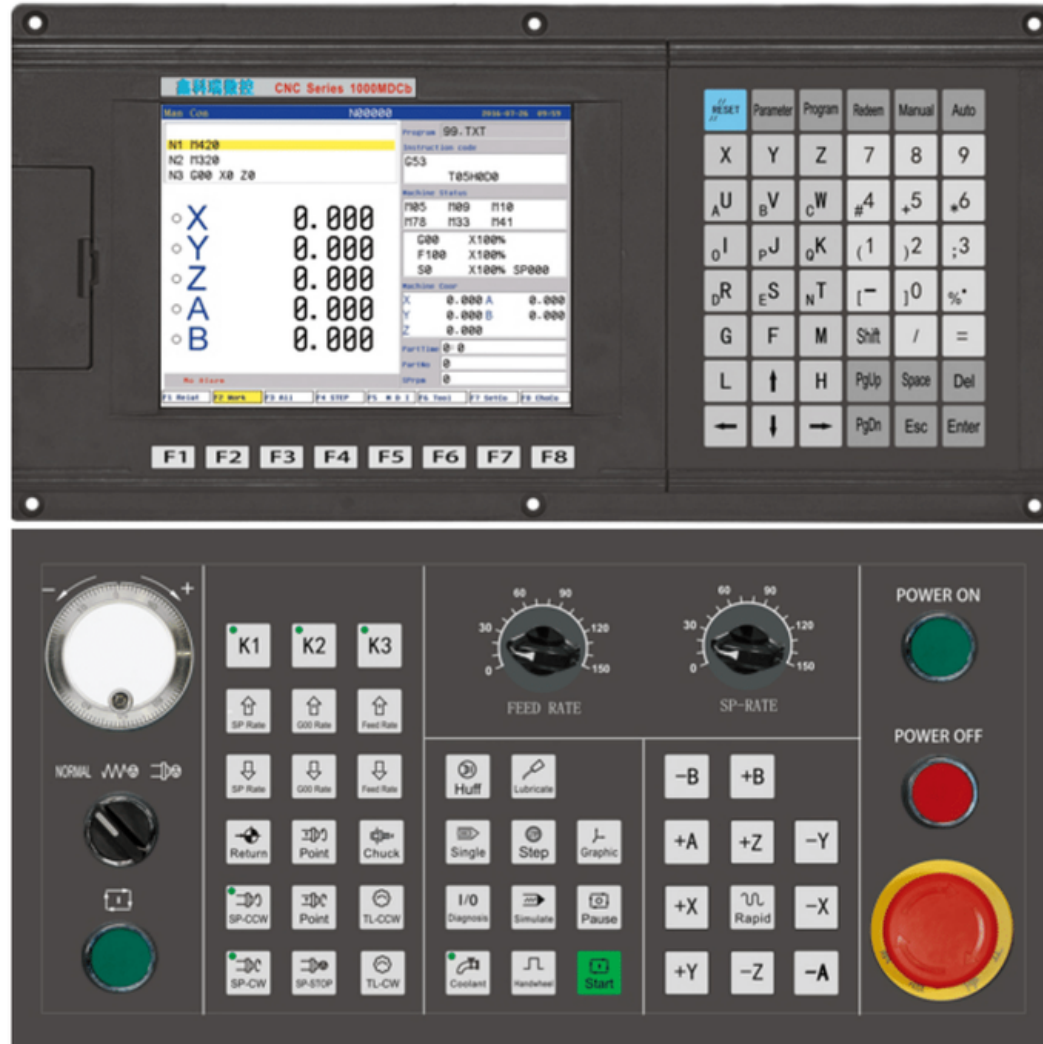

PRADO

AUTOMAÇÃO INDUSTRIAL

NEW1000MDC - Guia de Instalação



PRADO
AUTOMAÇÃO INDUSTRIAL

<https://pradoautomacaoindustrial.com.br>

email: vendas@pradoindustrial.com.br

(11) 5666-6461 / (11) 94242-8989 - WhatsApp

Installation instruction

990 series(2-4 axis)						
990T series			990M series			
990TDCa	990TDCb	16iT	990MDCa	990MDCb	16iM	
T: lathe machine M: milling machine Ca incremental(pulse+directon) Cb absolute(pulse+direction+RS485) i(modbus)						
1000 series						
1000T series			1000M series			
1000TDCa	1000TDCb	18iT	1000MDCa	1000MDCb	18iM	
1000TDC/1000MDC 2-5 axis			18iT/18iM 2-8 axis			
1500 series						
1500T series			1500M series			
1500TDCa	1500TDCb	15iT	1500MDCa	1500MDCb	15iM	
axis support same as 1000 series						
<i>Dual channel controller</i>			<i>robot arm controller</i>			
22iT/M(total max 16 axis)			NEWKer i series(4-12 axis)			
<i>Optional (machining center ATC for milling machine, special program)</i>						
1000MiCa/b		1500MiCa/b		18iMi		
<i>drive</i>						
DS series incremental drive						
DS301	DS302	DS501	DS503	DS753		
NEW series absolute drive						
NEW301	NEW302	NEW501	NEW503	NEW753		
Modbus drive						
NK301	NK302	NK501	NK503	NK753		
<i>Motor</i>						
incremental motor 2500PPR incremental encoder						
60 series	80 series	90 serie	110 series	130 series	150 series	180 series
absolute motor 17bit absolute encoder						
60 series	80 series	90 serie	110 series	130 series	150 series	180 series
<i>Configuration</i>						
incremental controller		+ incremental drive		+ incremental motor		
absolute controller		+ absolute drive		+ absolute motor		
		+ incremental drive		+ incremental motor		
Modbus controller		+ modbus drive		+ absolute motor		
		+ absolute drive		+ absolute motor		
		+ incremental drive		+ incremental motor		
<i>Robot arm</i>						
<i>MODEL</i>	<i>JOINTS</i>	<i>PAYLOAD(kgs)</i>	<i>RANGE(mm)</i>	<i>positioner</i>		
NKRM40814	4	8	1400	<i>welding machine</i>		
NKRM42017	4	20	1700	<i>spindle (servo drive+motor)</i>		
NKRM418031	4	180	3100	<i>transformer</i>		
NKRT60407	6	4	700			
NKRT1506B	6	6	1500			
NKRT1506A	6	6	1500			
NKRT1806A	6	6	1800			
NKRT1510A	6	10	1500			
NKRT2020A	6	20	2000			
NKRT1830A	6	30	1800			
NKRT1550A	6	50	1500			
NKRT2560A	6	60	2500			
NKRT2380A	6	80	2300			
NKRT627210	6	270	2100			

1. NEWKer Model

 **CNC Milling Controller** CE
 鑫科瑞数控

Model: NEW1000MDCa-4
Input Power: ~220V 50Hz **Power:** 100W
Serial Number: 20101000.13.149
Ex-factory Date: OCT,2020 **Note!**
 1. The system must be reliably grounded!
 2. Must be powered by an isolation transformer.

CHENGDU NEWKer CNC-TECHNOLOGY CO.,LTD
MADE IN CHINA

➤ Model Explanation

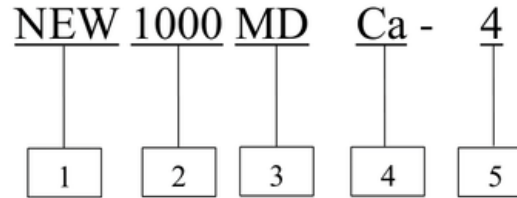

No.	Item	Description	Model meaning
1	Plant code	NEW	NEWKer product
2	Series code	990: integrated panel model; 1000: Standard panel model; 1500: Vertical panel model; 16i: Bus type integrated panel model; 18i: Bus type standard panel model; 15i: Bus type vertical panel model;	1000 series standard panel model
3	Application	TD: Lathe MD: Milling machine Mi: Milling machine with ATC function(1000/1500 series) T: Bus type for Lathe M: Bus type for milling machine Mi: bus type for milling machine with ATC function(18/15 series)	Milling controller
4	Function	Ca: incremental function(990/1000/1500 series) Cb: absolute function(990/1000/1500 series)	Incremental function
5	Axis number	2: 2 axis(XZ) 3: 3 axis(XYZ/XZC) 4: 4 axis(XYZA/XZCA) 5: 5 axis(XYZAB/XZCAB) 6: 6 axis(XYZABC/XZYABC) 7: 7 axis(XYZABCXs/XZYABCXs) 8: 8 axis(XYZABCXsYs/XZYABCXsYs)	4 axis(XYZA)

2. Controller Package List

No.	Item	Specification
1	Main panel	<input type="checkbox"/> NEW990T <input type="checkbox"/> NEW990M <input type="checkbox"/> NEW1000M <input type="checkbox"/> NEW1000T <input type="checkbox"/> NEW1500M <input type="checkbox"/> NEW1500T
2	Sub panel	<input type="checkbox"/> NEW1000M-A <input type="checkbox"/> NEW1000T-A <input type="checkbox"/> NEW1000M-B <input type="checkbox"/> NEW1000T-B <input type="checkbox"/> NEW1000M-C <input type="checkbox"/> NEW1000T-C <input type="checkbox"/> NEW1000M-E <input type="checkbox"/> NEW1000T-E <input type="checkbox"/> NEW1500M-A <input type="checkbox"/> NEW1500T-A <input type="checkbox"/> NEW1500M-B <input type="checkbox"/> NEW1500T-B
3	Power supply	<input checked="" type="checkbox"/> RD-65B
4	CN3(I/O1)	<input type="checkbox"/> 5 meters
5	CN4(I/O3)	<input type="checkbox"/> 5 meters
6	CN5(XYZ driver signal)	<input type="checkbox"/> 5 meters
7	CN6(AB driver signal)	<input type="checkbox"/> 5 meters
8	CN8(Power input)	<input type="checkbox"/> 5 meters
9	CN9(SP-encoder input)	<input type="checkbox"/> 5 meters
10	CN10(I/O2)	<input type="checkbox"/> 5 meters
11	CN11(MPG connection)	<input type="checkbox"/> Connector <input type="checkbox"/> MPG
12	CN13(Feedback input)	<input type="checkbox"/> 5 meters
13	CN15(Sub panel connection)	<input type="checkbox"/> 0.8 meters
14	CN16(I/O3)	<input type="checkbox"/> 5 meters
15	Relay board	<input type="checkbox"/> NEWKer-335P

Attention: please check package according to package list. Above items are included according to order, not all involved. if any customize requirements, please contact NEWKer staff

3. Controller connection

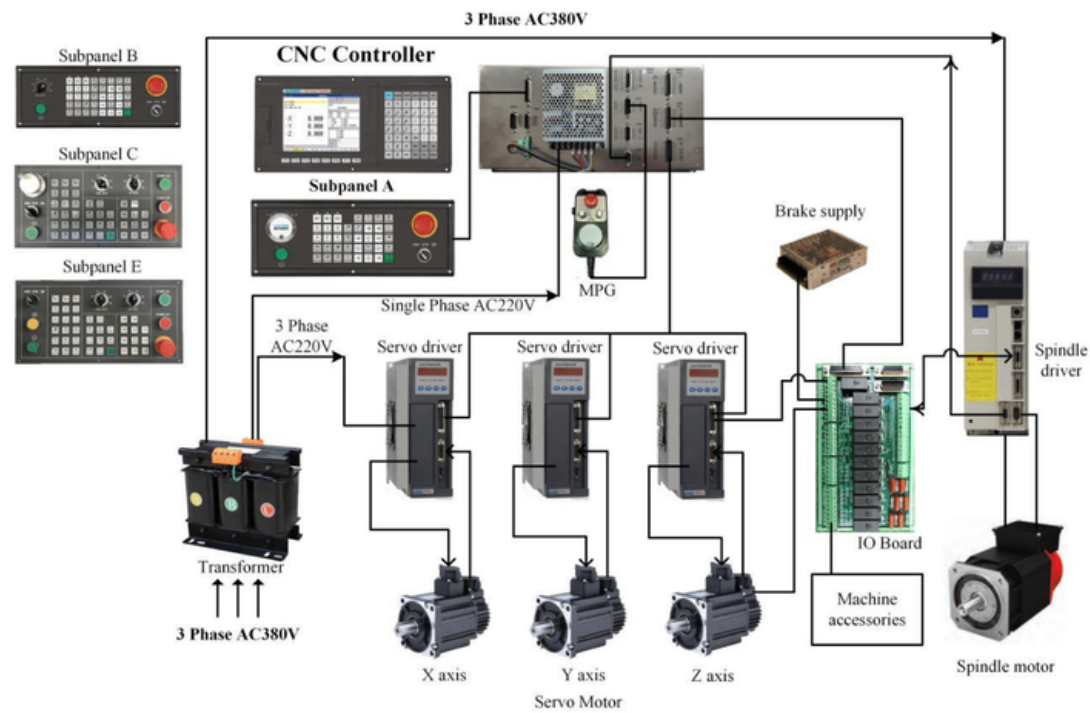

NEW1000MDCa-3 connection

Note: IO Board is optional, if without IO board, please connect IO according following IO chart.

4. Panel operation

A) NEW1000 series panel

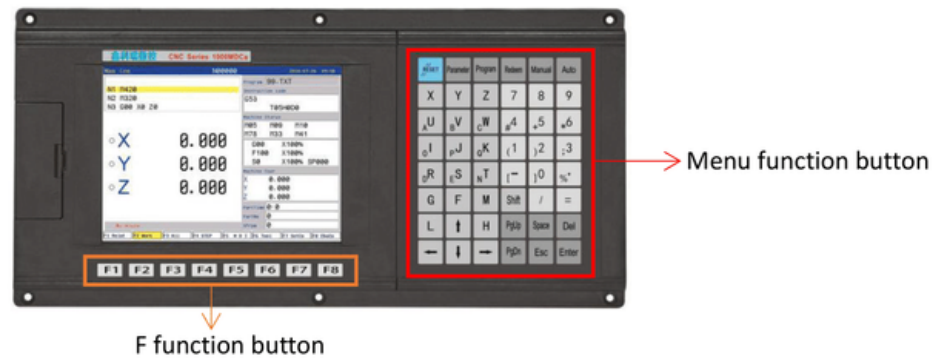

B) Sub panel



4. Servo axis control

Note: if purchase full kit from NEWKer, cable of driver connection is ready. Just check label on the cable and connect it with driver.

A) XYZ Servo drive

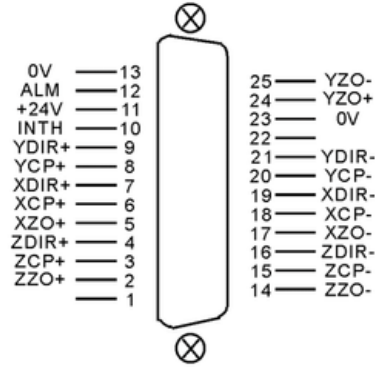

CN5 Servo driver control signal DB25 male socket				
Signal	Pin	I/O	Function	Effective level
XCP+/-	6/18	OUT	X axis pulse signal	5V
XDIR+/-	7/19	OUT	X axis direction signal	5V
YCP+/-	8/20	OUT	Y axis pulse signal	5V
YDIR+/-	9/21	OUT	Y axis direction signal	5V
XZO+/-	5/17	IN	X axis motor zero signal	5V
ZCP+/-	3/15	OUT	Z axis pulse signal	5V
ZDIR+/-	4/16	OUT	Z axis direction signal	5V
ZZO+/-	2/14	IN	Z axis motor zero signal	5V
YZO+/-	24/25	IN	Y axis motor zero signal	5V
ALM/0V	12/13	IN	ALM Servo alarm	0V
+24V/0V	11/23	OUT	+24V/0V	24V
INTH	10	OUT	Servo alarm reset	0V

B) Driver alarm

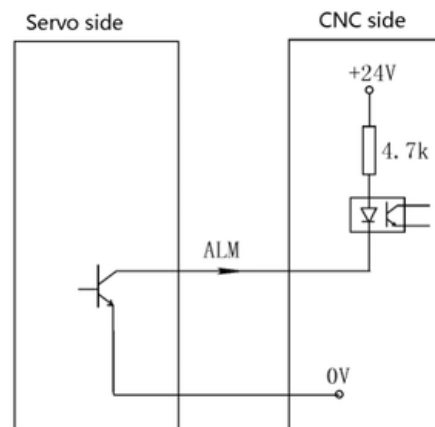

Driver alarm support Normal close/open mode, please check driver alarm output mode, and modify Other parameter P17.

Note: when power on controller and driver, if controller shows driver alarm while driver did not alarm, please revise Other parameter P17.

5. Basic parameter setting

A) NEW1000MDCa

- (a) Press **F3** enter into parameter setting, then press **F3** to go to Axis section
 (b) Electronic gear ratio setting(relative to axis movement correction):

Axis parameter:

P23 X-axis electronic gear numerator = reduction ratio*10;

The screenshot shows the CNC control interface with the following data:

Man Con	Read Only	N00000	2020-12-16 14:54
16,Z-axis's reverse compensati	0		
18,X-axis's direction signal:	0		
19,Y-axis's direction signal:	0		
20,Z-axis's direction signal:	0		
22,Close feed electron gear:	0		
23,X-axis's electron gear nume	1		
24,X-axis's electron gear deno	1		
25,Y-axis's electron gear nume	1		
26,Y-axis's electron gear deno	1		
27,Z-axis's electron gear nume	1		
28,Z-axis's electron gear deno	1		
31,XY2A positive limit:	0		
32,XY2A negative limit:	0		

Program: 123
 Progress: █
 G54
 T01H0D0
 TrueFeed: F 0.000
 M05 M09 M10
 M78 M33 M41
 G00 X100%
 F500 X100%
 S800 X100% SP000
 Machine Coord
 X 0.000
 Y 0.000
 Z 0.000
 PartTime: 0:0
 PartNo: 3076
 SPrpm: 0
 No Alarm
 F1 User F2 Speed **F3 Axis** F4 Tool F5 Other F6 Coord F7 PASSWD F8 CANCEL

P24 X-axis electronic gear denominator = ball screw pitch(mm)(axis movement per turn of motor)

The screenshot shows the CNC control interface with the following data:

Man Con	Read Only	N00000	2020-12-16 14:55
16,Z-axis's reverse compensati	0		
18,X-axis's direction signal:	0		
19,Y-axis's direction signal:	0		
20,Z-axis's direction signal:	0		
22,Close feed electron gear:	0		
23,X-axis's electron gear nume	1		
24,X-axis's electron gear deno	1		
25,Y-axis's electron gear nume	1		
26,Y-axis's electron gear deno	1		
27,Z-axis's electron gear nume	1		
28,Z-axis's electron gear deno	1		
31,XY2A positive limit:	0		
32,XY2A negative limit:	0		

Program: 123
 Progress: █
 G54
 T01H0D0
 TrueFeed: F 0.000
 M05 M09 M10
 M78 M33 M41
 G00 X100%
 F500 X100%
 S800 X100% SP000
 Machine Coord
 X 0.000
 Y 0.000
 Z 0.000
 PartTime: 0:0
 PartNo: 3076
 SPrpm: 0
 No Alarm
 F1 User F2 Speed **F3 Axis** F4 Tool F5 Other F6 Coord F7 PASSWD F8 CANCEL



After setting, Press **F** on the board to set speed, then press **F** to move X, and check if X axis real movement is real coordinate changes through dial gauge. For example, if machine coordinate changes by 10mm, dial gauge value should change by 10mm.

P25-P26 is Y axis electronic gear ratio. After setting, please also use dial gauge to check if Y real movement match with coordinate changes;

P27-P28 is Z axis electronic gear ratio. After setting, please also use dial gauge to check if Z real movement match with coordinate changes;

(c) Home process

Axis parameter

P38 Feed Axis home:

Value	Option	Definition
0	Clew	When power on, prompt a dialog to remind machine home operation;
1	No use	When power on, neither remind dialog nor constraint instruction;
8	Compulsion	When power on, prompt remind dialog to do home operation, and will not execute program in auto mode until home operation;
9	Must compulsion	When power on, prompt remind dialog to do home operation, and will not move axis in both manual and auto mode until home operation;

P39 Feed axis home mode:

Value	Option	Definition
0	Reverse check	After reach home switch, axis will move reversely to off switch and detect Z pulse signal from driver to double ensure home position;
1	Reverse no check	After reach home switch, axis will move reversely to off switch;
2	No reverse check	After reach home switch, axis will move forward to off switch and detect Z pulse signal from driver to double ensure home position;
3	No reverse no check	After reach home switch, axis will move forward to off switch;

P40 Home reverse direction:

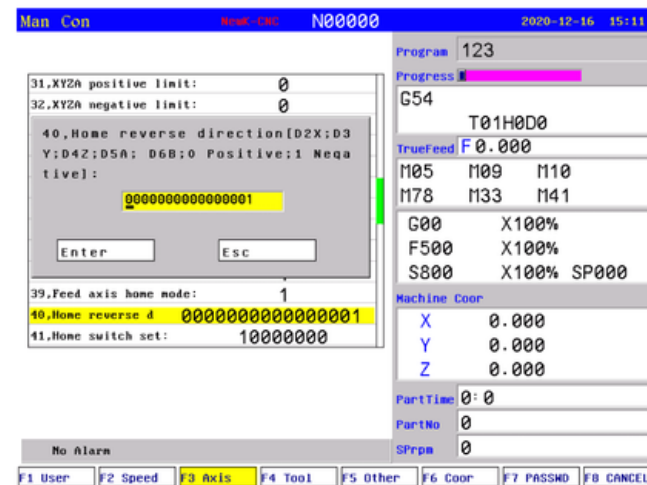

D15	D14	D13	D12	D11	D10	D9	D8	D7	D6	D5	D4	D3	D2	D1	D0
									B	A	Z	Y	X		

0: Positive direction;

1: Negative direction;

Note: when doing home operation, if axis moving direction is reversed from home sensor, please adjust Axis parameter P40 to modify the direction.

P41 Home switch set:

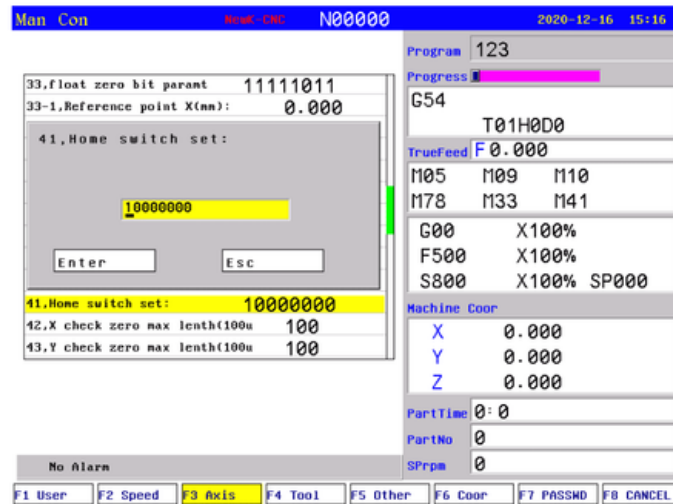

D6	D5	D4	D3	D2	D1	D0
		B	A	Z	Y	X

Used to set home sensor type:

- 1: Normal close;
- 0: Normal open;

Speed parameter

- P34 X home rampit speed: X axis go home speed in positive direction;
- P35 X home reverse speed: X axis go home speed in negative direction;
- P36 Y home rampit speed: Y axis go home speed in positive direction;
- P37 Y home reverse speed: Y axis go home speed in negative direction;
- P38 Z home rampit speed: Z axis go home speed in positive direction;
- P39 Z home reverse speed: Z axis go home speed in negative direction;

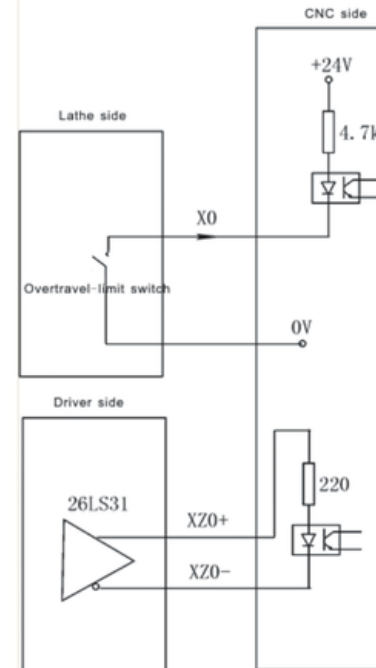
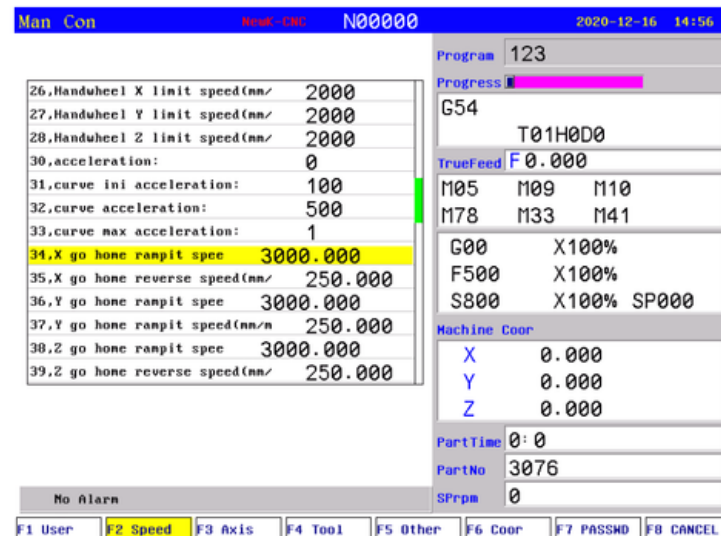

Installation instruction

(d) Spindle control

Item	Signal	Command	Relative Parameter	PLC address	Default I/O	Sample
1st Spindle	CW	M03	/	M53	Y14	M03 S1000
	CCW	M04	/	M54	Y13	
	Stop	M05	/	M55	Y12	
	Speed	S+speed	Speed parameter P42	/	CN3 Pin25	
2nd Spindle	CW	M203	/	M213	/	M203 SS1000
	CCW	M204	/	M212	/	
	Stop	M205	/	/	/	
	Speed	SS+speed	Speed parameter P46	/	CN10 Pin25	

The screenshot shows the CNC control interface with the following data:

- Parameter List:**
 - 42.Spindle first max speed(rpm) 3000
 - 43.Spindle second max speed(rp) 3000
 - 44.Spindle third max speed(rpm) 3000
 - 45.Spindle forth max speed(rpm) 3000
 - 46.Second Spindle max speed(rp) 3000
 - 47.reverse compensation mode(0) 8
 - 48.mode B reverse compensation 3000
 - 48-1.mode B reverse compensati 500
 - 48-2.mode B reverse compensati 60000
 - 49.speed Mode(1 Yes,0 No): 1
 - 49-1.Termination speed at reve 200
 - 50.Handwheel stop speed(mm/min) 100
 - 51.Follow the tapping knife wh 1
- Program 123:**
 - G54 T01H0D0
 - TrueFeed F 0.000
 - M05 M09 M10
 - M78 M33 M41
 - G00 X100%
 - F500 X100%
 - S800 X100% SP000** (Spindle speed command)
- Machine Coord:**
 - X 0.000
 - Y 0.000
 - Z 0.000
- PartTime:** 0:0
- PartNo:** 0
- SPrpm:** 0 (Spindle speed feedback)

(e) Input and Output

Press **F2** twice to enter into IO interface:

The two screenshots show the CNC control interface with the following data:

- Input Point:**
 - X00 X01 X02 X03 X04 X05 X06 X07
 - T01 T02 T03 T04 T05 T06 T07 T08
 - X08 X09 X10 X11 X12 X13 X14 X15
 - M34/R0 -L -L M36/Y0 X0 Z0 KRUN KHALT
 - X16 X17 X18 X19 X20 X21 X22 X23
 - X20 Z20 KLEFT KRRIGHT STOP TOR ALM ALM1
 - X24 X25 X26 X27 X28 X29 X30 X31
 - ALM2 M20 M24 M22 M18 M12 M14 M16
 - X32 X33 X34 X35 X36 X37 X38 X39
 - RK HY HZ HA HK1 HK10 HD100 HDFF
 - X40 X41 X42 X43 X44 X45 X46 X47
 - X60 X61 X62 X63 X64 X65 X66 X67
 - DS3 DS2 DS1 DS0 DK3 DK2 DK1 DK0
- Output Point:**
 - Y00 Y01 Y02 Y03 Y04 Y05 Y06 Y07
 - M51 M53 M55 M57 M59 M61 M63 M65
 - Y08 Y09 Y10 Y11 Y12 Y13 Y14 Y15
 - M32 M79 M10 M08 M05 M04 M03 M75
 - Y16 Y17 Y18 Y19 Y20 Y21 Y22 Y23
 - LRUN INTN +F -T S04 S03 S02 S01
 - Y24 Y25 Y26 Y27 Y28 Y29 Y30 Y31
- Program 123:**
 - G54 T01H0D0
 - TrueFeed F 0.000
 - M05 M09 M10
 - M78 M33 M41
 - G00 X100%
 - F500 X100%
 - S800 X100% SP000
- Machine Coord:**
 - X 0.000
 - Y 0.000
 - Z 0.000
- PartTime:** 0:0
- PartNo:** 0
- SPrpm:** 0

1) Input point

Installation instruction

Signal	Command	Pin	Function	Relative parameter
X00	T01	CN4 Pin1	User-define input	/
X01	T02	CN4 Pin2	User-define input	/
X02	T03	CN4 Pin3	User-define input	/
X03	T04	CN4 Pin4	User-define input	/
X04	T05	CN4 Pin5	User-define input	/
X05	T06	CN4 Pin6	User-define input	/
X06	T07	CN4 Pin7	User-define input	/
X07	T08	CN4 Pin8	User-define input	/
X08	M34/A0	CN3 Pin4	User-define input/A axis home signal	Axis parameter P41
X09	-L	CN3 Pin15	Machine negative hard limit switch	Axis parameter P32
X10	+L	CN3 Pin16	Machine positive hard limit switch	Axis parameter P31
X11	M36/Y0	CN3 Pin2	User-define input/Y axis home signal	Axis parameter P41
X12	X0	CN3 Pin3	X axis home signal	Axis parameter P41
X13	Z0	CN3 Pin17	Z axis home signal	Axis parameter P41
X14	KRUN	CN3 Pin18	External Start button	/
X15	KHALT	CN3 Pin6	External Pause button	/
X16	XZ0	/	/	/
X17	ZZ0	/	/	/
X18	KLEFT	CN6 Pin4	Left of interfere switch	Other parameter P3
X19	KRIGHT	CN6 Pin7	Right of interfere switch	
X20	STOP	CN6 Pin9	External E-Stop	Other parameter P26, P27
X21	TOK	CN4 Pin9	Turret lock ready	/
X22	ALM	CN5 Pin12	Servo driver alarm	Other parameter P17
X23	ALM1	CN3 Pin5	Spindle driver alarm	Other parameter P18
X24	ALM2	CN10 Pin2	Lubricant alarm	Other parameter P19
X25	M28	CN10 Pin23	User-define input	/
X26	M24	CN10 Pin3	User-define input	/
X27	M22	CN10 Pin5	User-define input	/
X28	M18	CN10 Pin10	User-define input	/
X29	M12	CN10 Pin11	User-define input	/
X30	M14	CN10 Pin24	User-define input	/
X31	M16	CN10 Pin12	User-define input	/
X40	/	CN16 Pin1	User-define input	/
X41	/	CN16 Pin2	User-define input	/
X42	/	CN16 Pin3	User-define input	/
X43	/	CN16 Pin4	User-define input	/
X44	/	CN16 Pin5	User-define input	/
X45	/	CN16 Pin6	User-define input	/
X46	/	CN16 Pin7	User-define input	/
X47	/	CN16 Pin8	User-define input	/

Attention: Common terminal of all input points is 0V, and input points are 0V effective;

Note: if controller prompt driver alarm while servo driver does not alarm, please set Other parameter P17.

2) Output point

Installation instruction

Signal	Command	Pin	Function	Relative parameter
Y00	M61	CN10 Pin19	User-define Output	/
Y01	M63	CN10 Pin7	User-define Output	/
Y02	M65	CN10 Pin20	User-define Output	/
Y03	M67	CN10 Pin8	User-define Output	/
Y04	M69	CN10 Pin21	User-define Output	/
Y05	M71	CN10 Pin9	User-define Output	/
Y06	M73	CN10 Pin22	User-define Output	/
Y07	M59	CN10 Pin6	Huff	/
Y08	M32	CN3 Pin9	Lubricant	Other parameter P4-P6
Y09	M79	CN3 Pin22	User-define Output	/
Y10	M10	CN3 Pin21	Spindle chuck	Other parameter P13, P20,P22,P24
Y11	M08	CN3 Pin8	Coolant	Other parameter P14
Y12	M05	CN3 Pin20	Spindle stop	Axis parameter P11-P12
Y13	M04	CN3 Pin7	Spindle CCW	/
Y14	M03	CN3 Pin19	Spindle CW	/
Y15	M75	CN3 Pin12	User-define Output	/
Y16	LRUN	/	/	/
Y17	INTH	CN5 Pin10	Servo alarm reset	/
Y18	+T	CN4 Pin12	User-define Output	/
Y19	-T	CN4 Pin13	User-define Output	/
Y20	S04(M44)	CN3 Pin24	Spindle 4th gear	Speed parameter P45
Y21	S03(M43)	CN3 Pin11	Spindle 3rd gear	Speed parameter P44
Y22	S02(M42)	CN3 Pin23	Spindle 2nd gear	Speed parameter P43
Y23	S01(M41)	CN3 Pin10	Spindle 1st gear	Speed parameter P42
Y24	/	CN16 Pin11	User-define Output	/
Y25	/	CN16 Pin12	User-define Output	/
Y26	/	CN16 Pin13	User-define Output	/
Y27	/	CN16 Pin14	User-define Output	/
Y28	/	CN16 Pin15	User-define Output	/
Y29	/	CN16 Pin16	User-define Output	/
Y30	/	CN16 Pin17	User-define Output	/
Y31	/	CN16 Pin18	User-define Output	/

Attention: Common terminal of all output points is 24V, and output points are 0V effective;
Sample: when run M61, Y00 will be on; when run M60, Y00 will be off.



PRADO

AUTOMAÇÃO INDUSTRIAL