



# PRADO

AUTOMAÇÃO INDUSTRIAL

## NEW990TDca Manual



<https://pradoautomacaoindustrial.com.br>

email: [vendas@pradoindustrial.com.br](mailto:vendas@pradoindustrial.com.br)

(11) 5666-6461 / (11) 94242-8989 - WhatsApp

## CONTENTS

Chapter 1	Preface	3
Chapter 2	System technical features	4
2.1	System structure	4
2.2	System technical parameter	4
2.3	System function	4
2.4	System operation condition	5
Chapter 3	Operation explanation	7
3.1	Panel layout and switch (Two types)	7
3.2	operation interface	9
3.3	Parameter	10
3.4	Programming	26
3.5	Manual	31
3.6	Automatic	34
3.7	Tool redeem	35
Chapter 4	Programming	37
4.1	Basic concepts	37
4.2	Program instruction	38
4.3	Preparation functions	44
Chapter 5	System installation and connection	77
5.1	System installation connection	77
5.2	System installation dimension	78
5.3	System rear view	80
5.4	interface connection graph	80
Chapter 6	System' s daily maintenance and repair	92
Chapter 7	Appendix	94

## Chapter 1 Preface

This CNC control system is one middle class flush type CNC control system, aiming specially at lathe and grinding machine.

Based on modern computer technology, system move control core & PLC program running technology, and stable unique real time control engine subsystem PTAI, this system ensures the stabilization of operation. The use of high performance, low power consumption industrial grade ARM microprocessor as core of hardware, large scale FPGA integrate circuit, multiple layer (4,6) printed circuit, 32MB flash memory, 8 inch real colour LCD which provides friendly man-machine dialogue interface makes this system work to its best.

### Note for “caution”:

1、“caution” reminds operator must be *caution* in the relative operation, otherwise the operation will fail or some action can not be effected.

2、“special caution” reminds operator must be *special caution* in the relative operation, otherwise it may break down the machine or give rise to accident.

### Special hint:

This system has function to backup parameters. After debugging machine, it can backup all parameters of machine & system and PLC documents to computer. It is convenient not only for mass debugging, but also for machine recovery to normal after changing system.

### Note :

**When use this system for the first time, please read carefully all the details of each chapter so as to make it work more efficiently.**

## Chapter 2 System technical features

### 2.1 System constructions

32 bits high performance, low power consumption industrial grade ARM microprocessor.

64MB memory.

32Mb user store room.

640x480 8 inch real colour LCD displayer.

Touch screen main and sub panel.

High anti-jamming switch power.

USB movable U disc copy interface.

RS232 interface.

Spindle servo speed control/spindle frequency conversion speed control.

Manual pulse generator.

### 2.2 System technical parameter

controllable axes: X、Z、C/Y、A four axes.

linkage axes: Arc 2-3 axes, liner 2-4 axes.

pulse equivalent: X、Z、C/Y、A axes:0.001mm.

max speed: X、Z、C/Y、A:60000mm/min.

cutting speed: 1-10000mm/min.

min input unit: 0.001mm.

program size range:  $\pm$  99999.999.

99 tools management.

controllable liner vertical type or revolving disc type tool changer.

program code: ISO-840 international standard.

program coordinate system definition: ISO-841.

chassis protection complies with regulation of IP43.

### 2.3 System function

#### 2.3.1 Auto-diagnosis function

All around diagnosis of CPU, storer, LCD, I/O interface, parameter status, coordinates, machining program etc. shall execute when the system starts or resets. In operation, it makes real time diagnosis of

power, spindle, limit and all I/O interface.

### **2.3.2 Compensation function**

automatic backlash compensation.  
tool radius automatic compensation.  
tool radius automatic offset and sharp angle transition.  
leading screw pitch error automatic compensation.

### **2.3.3 Abundant instruction system**

scaling up/down instruction.  
mirror machining instruction.  
multiple tool offset instruction.  
program cycle, jump, call and different program ending.  
multiple positioning instruction: starting point, setting fixed point, etc.  
linear, circular, spiral line interpolation instruction.  
program management instructions: program cycle, call, transfer and different program ending method, etc.  
6 workpieces coordinates system .

### **2.3.4 Chinese/English menu, full screen edition**

Easy operation, convenient viewing.

### **2.3.5 Abundant debugging functions**

it can point out clearly what errors of operation are and guide to correct them.

### **2.3.6 Program changing between CNC system and IBM/PC series**

#### **compatible computer**

it can conduct CAD/CAM/CAPP auxiliary programming by using Pc series compatible computer's abundant software resources, then transfer the CNC program into the system to machining through (USB movable U disc copy port, RS232 port). Likewise it also can transfer the program from system to PC through communication port.

## **2.4 System operation condition**

### **2.4.1 Power supplying**

AC 220V(+10%/-15%), Frequency 50Hz $\pm$ 2%. power:  $\leq$  200W.

Note: it must use isolation transformer to supply power, first input:380V

### **2.4.2 Climate condition**

operation condition: temperature 0~45°C, relative moisture 40-80 %.

storage & transportation condition: temperature -40~55°C, relative moisture <93% (40°C).

atmosphere pressure: 86-106kpa.

### **2.4.3 operation enviorment:**



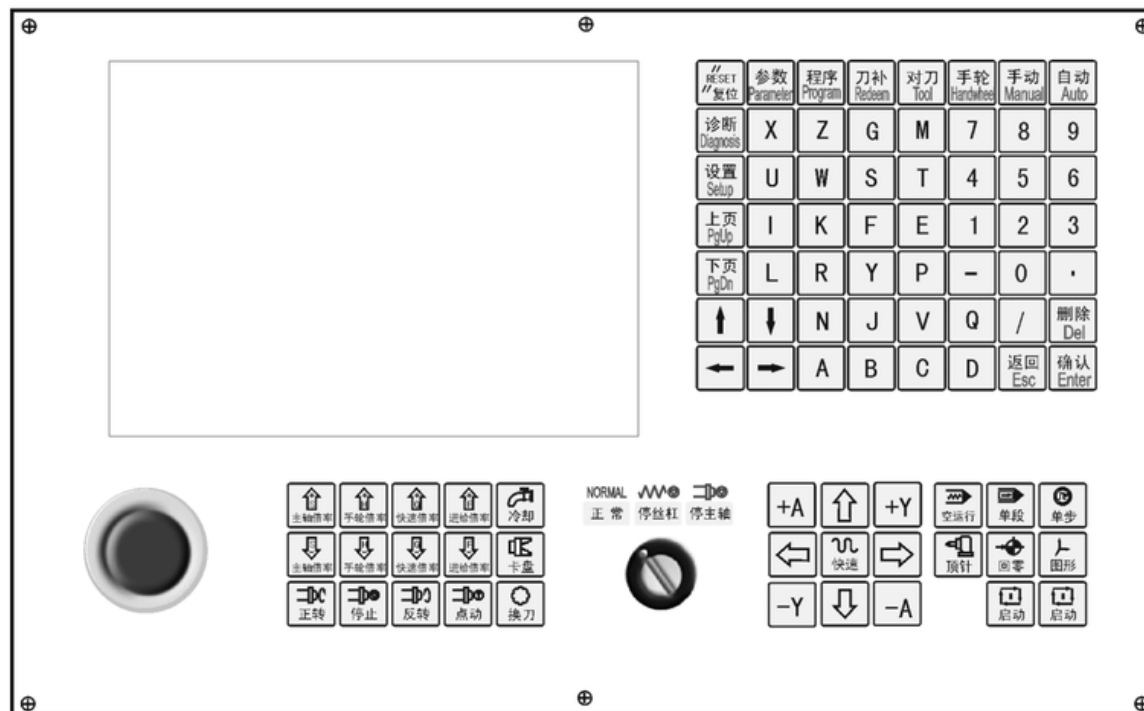
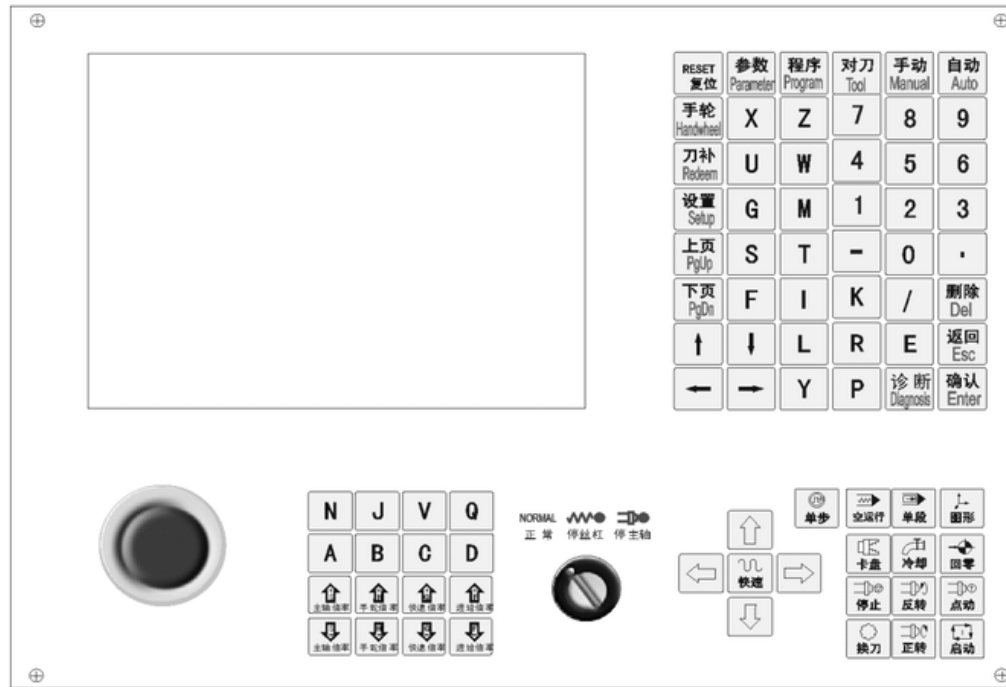

No excessive flour dust, no acid, no alkali gas and explosive gas, no strong electromagnetic interference.

## Chapter 3 Operation explanation

### 3.1 Panel layout and switch (Two types)







switch introduction:



















Switch	Functions
	Emergency stop Driver and motor stop immediately, turns off the spindle, coolant, waits for the rise of button, and initializes values
<p>NORMAL  </p> <p>正常 停丝杠 停主轴</p> 	<p>Feed axes percentage switch: When program runs or in manual state, it can make a realtime adjustment of feed speed;</p> <p>Spindle percentage switch: In the process of spindle running, adjusts the speed accordingly.</p>

buttons:

Keyboards	Functions
Letter key Number key	ABCSEFGHIJKLMNOPQRSTUVWXYZ123456789.-: for program instructions, parameters' edition; number keys are used for inputting data and selecting sub-menu.
Edit key	“↑、↓、→、←、Del、PgUp、PgDn” for programming, direction keys can be used for selecting menu.



Function key	<p>“Esc” returning to upper level or stop a operation</p> <p>“Enter” selecting sub-menu and changing a newline</p> <p>“Del” delete program</p> <p>“program” entering program edition</p> <p>“parameter” entering parameter setting</p> <p>“diagnsos” entering diagnosis I/o function</p> <p>“manual” entering manual status</p> <p>“handwheel” for starting or stopping handwheel function</p> <p>“Tool” for confirming current tool ‘s position in machine tool coordinates system.</p> <p>“Redeem” for amending tool change errors</p> <p>“Auto” entering automatic status</p> <p>“MDI ” entering MDI function</p> <p>“  ” selecting auto-coordinates/diagram machining</p> <p>“  ” for single segment or constant work</p> <p>“  ” for coordinates mode or diagram mode speedy simulating</p> <p>“  ” for manual increment or constant work</p>
-----------------	--

Control key	<p>“            ” spindle cw, ccw rotation</p> <p>“” coolant on/off</p> <p>“” for the shift between electric tool carrier and gang tool carrier</p> <p>“” for the shift between hand-driven continuous high speed and low speed.</p> <p>“” all axes return to datum point</p> <p>“” for spindle chuck on/off</p> <p>“” for thumbstall on/off</p> <p>“” handwheel gear selection</p> <p>“” adjusting spindle speed</p> <p>“” adjusting feed speed</p> <p>“” adjusting G00 speed</p>
Feed key	<p>    +Y +A -Y -A</p> <p>For X、Y、Z、A axes direction feed</p>

### 3.2 operation interface

Whole system adopts multi-leveled menu full screen operation, user-friendly interface, providing comprehensive information. It enters into main interface when electrified:

Man Con		N0000		2012-12-21 19:26	
N1 M03 S600 N2 G00 X200 Z200 N3 G00 U-44			Program 99.TXT Instruction code G53 T0001		
<input type="radio"/> X 65.000 <input type="radio"/> Z 161.096 <input type="radio"/> C 0.000 <input type="radio"/> A 0.000			Machine Status M05 M09 M10 M78 M33 M70 G00 X100% F6000 X100% S50 X100%		
No Alarm			Machine Coord X 166.000 Z 161.096 C 0.000		
			PartTime 0:15 PartNo 17 SPrpm 0		

### 3.3 Parameters

Man Con		N00000		2012-12-21 19:26	
1,Cycle G71/G72	50	Program	99.TXT		
2,Cycle G71/G72	10	Instruction code	G53		
3,GG71G72G173 i	0		T0001		
4,G71/G72/G73 d	20	Machine Status	M05 M09 M10		
5,G71/G72/G73 d	20		M78 M33 M70		
6,G73 cutting t	1		G00 X100%		
7,G73 X rough t	10		F6000 X100%		
8,G73 Z rough t	10		S50 X100%		
9,G74/G75 defau	50	Machine Coord	X 166.000		
10,G74/G75 defa	10		Z 161.096		
11,G76 finish t	1		C 0.000		
12,G76 quit len	10	PartTime	0: 15		
13,G76 thread t	60	PartNo	17		
N-User	J-Speed	V-Axis	Q-Tool	SPrpm	0
A-Other	B-Coor	C-PASSWD	D-CANCEL		
No Alarm					

In main menu, pressing “Parameter” function key, it enters para setting status, including “User”, “Speed”, “Axis”, “Tool”, “Other”, “Coor>>”, “Passwd”, seven function. Choose pressing “N、J、V、Q、A、B、C” choose

Except for special note, all data are using mm.

### 3.3.1 User parameter

1,Cycle G71/G72 default feed thickness(10um)

[X axis radius]

Cycle G71 X axis feed thickness; Cycle G72 Z axis feed thickness;

2,Cycle G71/G72 default backward distance(10um)

[X axis radius]

Cycle G71 X axis backward thickness; Cycle G72 Z axis backward thickness.

3,G71G72G173 instruction

[1 mean Yes, 0 mean No]

“1” mean G71/G72/G73 instruction finish machining.

4,G71/G72/G73 default X remain(10um)

5,G71/G72/G73 default Z remain(10um)

- 6, G73 cutting times
- 7, G73 X rough thickness(10um)  
[X axis radius]
- 8, G73 Z rough thickness(10um)
- 9, G74/G75 default feed thickness(10um)  
[X axis radius]
- 10, G74/G75 default backward distance(10um)  
[X axis radius]
- 11, G76 finish turn times
- 12, G76 quit length(1/10 lead)
- 13, G76 thread tooth angle(degree)  
[0~180° ]
- 14, G76 minimal cutting depth(10um)  
[X axis radius]
- 15, G76 finish turn remaining(10um)
- 16, X program mode  
[1 mean Radius, 0 mean Diamete]
- 17, Running program need Sp run  
[1 mean Yes, 0 mean No]
- 18, Set M20 the time of auto-running  
[Negative mean immensity loop]
- 19, Set part count
- 20, G92 quit length(1/10 lead)
- 21, G01/G02/G03 line delay(ms) [>100]
- 22, G00 line delay(ms) [>100]
- 23, Handwheel acceleration[50-100]
- 24, G76 Q  
[8 mean thick forward number]
- 200, system screen protect times  
[>=2minutes]
- 201, G92/G76 delay time(ms) [>100]
- 202, system inner parameter

### **3.3.2 Speed parameter**

- 1, X-axis' s G00 speed(mm/min)
- 2, Z-axis' s G00 speed(mm/min)
- 3, Manual maxminum feed speed(mm/min)
- 4, Auto Maximum feed speed(mm/min)

- 5, G01/G02/G03 default speed(mm/min)
- 6, Null run speed(mm/min)
- 7, Feed axis`s manual speed(mm/min)
- 8, Spindle`s manual speed(rpm)
- 9, Beginning feed speed(mm/min)
- 10, Jump speed at continuous track(mm/min)
- 11, Limit G1G2G3 axis speed  
[1 mean Yes, 0 mean No]
- 12, X G1G2G3 max speed(mm/min)
- 13, Z G1G2G3 max speed(mm/min)
- 14, X acceleration  
[1~99999]
- 15, Z acceleration  
[1~99999]
- 16, Auto run acceleration  
[1-500]
- 17, Handwheel acceleration  
[500--30000]
- 18, Run program Handwheel acceleration  
[>500]
- 19, Run program Handwheel G00 speed(mm/min)  
[>10]
- 20, Handwheel X limit speed(mm/min)
- 21, Handwheel Z limit speed(mm/min)
- 22, Make thread Z acceleration  
[Servo motor is 0]
- 23, Make thread X acceleration  
[Servo motor is 0]
- 24, Servo motor screw thread X axis Back speed
- 25, Step motor screw thread X axis Back rise speed
- 26, Step moter screw thread X axis Back Max speed
- 27, acceleration type  
[0 mean line, 8 mean curve]
- 28, curve ini acceleration  
[>=10]
- 29, curve acceleration  
[>=10]
- 30, curve max acceleration

[>=500]  
 31, X go home rampit speed(mm/min)  
 32, X go home reverse speed(mm/min)  
 33, Z go home rampit speed(mm/min)  
 34, Z go home reverse speed(mm/min)  
 35, G96 spindle min speed(rpm)  
 36, Spindle first max speed(rpm)  
 37, Spindle second max speed(rpm)  
 38, Spindle third max speed(rpm)  
 39, Spindle forth max speed(rpm)  
 40, Second Spindle max speed(rpm)  
 41, G02/G03reverse compensation mode(0 mean A; 8 mean B)  
 42, mode B reverse compensation speed(mm/min)  
 42-1, mode B reverse compensation Beginning feed speed(mm/min)  
 42-2, mode B reverse compensation acceleration(mm/min/s)  
 43, Handwheel stop speed(mm/min) [>100]  
 58, Forcedly limit drop speed critical(mm/min)

### 3.3.3 Axis parameter

1, Feed axis band switch  
 [1 mean Yes, 0 mean No]  
 2, Spindle band switch  
 [1 mean Yes, 0 mean No]  
 3, X-axis`'s negative scope(mm)  
 4, X-axis`'s positive scope(mm)  
 5, Y-axis`'s negative scope(mm)  
 6, Y-axis`'s positive scope(mm)  
 7, Z-axis`'s negative scope(mm)  
 8, Z-axis`'s positive scope(mm)  
 9, A-axis`'s negative scope(mm)  
 10, A-axis`'s positive scope(mm)  
 11, Spindle stop time(10ms)  
 12, Spindle stop long signal  
 [0 mean No, 1 mean Yes]  
 13, Soft limit invalid  
 [D2X;D3Y;D4Z;D5A;0 inavaild, 0 availd]  
 14, X-axis`'s reverse compensation(um)  
 15, Y-axis`'s reverse compensation(um)  
 16, Z-axis`'s reverse compensation(um)  
 17, A-axis`'s reverse compensation(um)  
 18, X-axis`'s direction signal

[1 mean normal, 0 mean reverse]  
19, Y-axis's direction signal  
[1 mean normal, 0 mean reverse]  
20, Z-axis's direction signal  
[1 mean normal, 0 mean reverse]  
21, A-axis's direction signal  
[1 mean normal, 0 mean reverse]  
22, Close feed electron gear  
[1 mean Yes, 0 mean No]  
23, X-axis's electron gear numerator(1-999999)  
24, X-axis's electron gear denominator(1-999999)  
25, Y-axis's electron gear numerator(1-999999)  
26, Y-axis's electron gear denominator(1-999999)  
27, Z-axis's electron gear numerator(1-999999)  
28, Z-axis's electron gear denominator(1-999999)  
29, A-axis's electron gear numerator(1-999999)  
30, A-axis's electron gear denominator(1-999999)  
31, XYZA positive limit  
[0 open, 1 close]  
32, XYZA negative limit  
[0 open, 1 close]  
33, float zero bit paramter  
[D3X;D4Y;D5Z;D6A;0 machine Zero;1 float Zero]  
34, X coor float zero set  
35, Y coor float zero set  
36, Z coor float zero set  
37, A coor float zero set  
38, Feed axis home  
[1 mean No use, 0 mean clew, 8 compulsion , 9 must compulsion]  
39, Feed axis home mode  
[0 reverse check, 1 reverse No check , 2 No reverse check, 3 No reverse No  
check]  
40, Home reverse direction  
[D2X;D3Y;D4Z;D5A; 0 Positive;1 Neqative]  
41, Home switch set  
[D0X;D1Y;D2Z;D3A;1Close;00pen]  
42, X check zero max lenth(100um)  
43, Y check zero max lenth(100um)  
44, Z check zero max lenth(100um)  
45, A check zero max lenth(100um)  
46, X Home offset(10um)  
47, Y Home offset(10um)  
48, Z Home offset(10um)  
49, A Home offset(10um)  
50, Have Spindle class control



[1 mean open, 0 mean close]  
 51, Spindle class speed(1/100rpm)  
 52, Spindle class direction  
 [0 mean M03, 1 mean M04]  
 53, Spindle class stop time(10ms)  
 54, Spindle class time(10ms)  
 55, Spindle stop time(10ms)  
 56, Check SP encode  
 [1 mean Yes, 0 mean No]  
 57, SP encode pulse  
 80, XZ axis coordinate  
 plan[D2Zwordpiece, D3Xwordpiece, D4Ztool, D5Xtool, D6Zcircumrotate, D7Xci  
 rcumrotate]  
 81, Y axis  
 [0 mean circumrotate axis, 1 mean line axis]  
 82, Y is circumrotate axis work coordinate  
 [0 No; 1 plan]  
 83, Y is circumrotate axis machine coordinate  
 [0 No; 1 plan]  
 100, Inner paramter  
 101, A-axis function  
 [0 mean circumrotate axis, 1 mean line axis]  
 102, A-axis is circumrotate axis machine coordinate  
 [0 No; 1 plan]  
 404, SP motor direction(0 reverse, 1 normal)  
 405, SP-axis's electron gear(0 Yes, 1 No)  
 406, SP-axis's electron low gear numerator(1-999999)  
 407, SP-axis's electron low gear denominator(1-999999)  
 408, SP-axis's electron high gear numerator(1-999999)  
 409, SP-axis's electron high gear denominator(1-999999)  
 410, Interpolation tap SP name[91 X, 92 Y/C, 93 Z, 94 A, 95 B]  
 411, Interpolation tap mode[2 follow encode; 3 interpolation to SP]  
 412, SP tooth number(<P413)  
 413, Encode number(>P412)

### 3.3.4 Tool parameter

1, Active tool function  
 [1 mean Yes, 0 mean No]  
 2, Active tool number  
 3, Lather type  
 4, Tool positive rotate max-time(s)  
 5, Delay time after tool positive rotate(ms)  
 6, Delay time after tool stop(ms)

- 7, Tighten time of tool reverse rotate(ms)
- 9, Have total signal TOK(1 mean have)
- 10, C Tool radius compensation's establish(0 mean A, 1 mean B)
- 11, C Tool radius compensation's cancel(0 mean A, 1 mean B)
- 20, Active tool mode  
[1 mean normal, 0 mean coding tool]

### 3.3.5 Other parameter

- 1, Set sub-panel type  
[1 hand hold, 0 panel]
- 2, lather outside chuck  
[1 extroversion, 0 diffidence]
- 3, use control switch  
[1 Yes, 0 No]
- 4, Have auto lubricate(0 yes/1 no)
- 5, Auto lubricate time(0.01s)
- 6, Auto lubricate stop time(s)
- 7, Door switch checking M12(0 no, 1 yes)
- 8, Door switch(0 open, 1 close)
- 9, bit paramter
  - D0: Null;
  - D1: "1" Start cnc system clear part Number.;
  - D2: "1" Automatic space before letter when editing program;
  - D3: Null;
  - D4: Null;
  - D5: "1" Do not stopping SP and cooling when pressing "Restet" ;
  - D6: "1" G00 XZ' speed by oneself;
  - D7: "1" Tool' redeem by oneself;
  - D8: "1" Save SP chuck(M10/M11) state when power off;
  - D9: Tool redeem input Model or Mode2;
  - D10: "1" Program edit automatic compositor Line;
  - D11: "1" Frist SP +10V output from second output port;
  - D12: "1" Shield skip function ( "/" is invalidation);
  - D13: "1" Sheld go home function;
  - D14: "1" Sheld "run" key;
  - D15: "1" Tool redeem display relative, "0" absolute;
- 10, Auto count part  
[1 mean Yes, 0 mean No]

- 11, Program edit number increase
- 12, Inner paramter
- 13, Does lock for Spindle & chuck(0 mean no)
- 14, Is availabe keys of lub&cool as runing(0 mean no)
- 15, Chuck clamp M10/loose M11 checking(1 mean need)
- 16, Finial forward M79/backward M78 checking(1 mean need)
- 17, servo ALM1 (0 open, 1 close)
- 18, SP ALM2 (0 open, 1 close)
- 19, Tool ALM3 (0 open, 1 close)
- 20, Chuck control signal(0 single, 1 doubleM10/M71)
- 21, finial control signal(0 single, 1 doubleM79/M73)
- 22, Outside chuck control(0 no, 1 yes)
- 23, Outside finial control(0 no, 1 yes)
- 24, M10M11 short signal time(s)
- 25, M79M78 short signal time(s)
- 26, Emerge Stop(0 open, 1 close)
- 27, Emerge Stop2(0 open, 1 close)
- 28, Run status output M69 STOP output M65(0 invalid, 1 valid)
- 29, Alarm status output M67(0 invalid, 1 valid)
- 30, Set language(1 表中文, 0 mean English)
- 31, Is enable I/O PLC program
- 32, Is enable High speed I/O PLC program
- 33, HY make run signal  
[1 mean Yes, 0 mean No]
- 34, HA make stop signal  
[1 mean Yes, 0 mean No]
- 35, soft-limit without home as manual  
[1 Yes, 0 No]
- 36, Set system time  
[year-month-day-hour-minute]
- 37, Velocity of RS232  
[0=7200; 1=9600; 2=14400; 3=19200; 4=38400; 5=57600; 6=115200]
- 38, Lock Manual rampit func key  
[8 Yes]
- 39, Special paramter
- 40, Special paramter
- 41, Bake current paramter
- 42, Resume original paramter

- 601, Make current to Step Motor Parameter
- 602, Make current to Step Servo Parameter

### **3.3.6 Work coordinator parameter**

- 1, X of work coordinates G54 (mm)
- 2, C(Y) of work coordinates G54 (mm)
- 3, Z of work coordinates G54 (mm)
- 4, A of work coordinates G54 (mm)
- 6, X of work coordinates G55 (mm)
- 7, C(Y) of work coordinates G55 (mm)
- 8, Z of work coordinates G55 (mm)
- 9, A of work coordinates G55 (mm)
- 11, X of work coordinates G56 (mm)
- 12, C(Y) of work coordinates G56 (mm)
- 13, Z of work coordinates G56 (mm)
- 14, A of work coordinates G56 (mm)
- 16, X of work coordinates G57 (mm)
- 17, C(Y) of work coordinates G57 (mm)
- 18, Z of work coordinates G57 (mm)
- 19, A of work coordinates G57 (mm)
- 21, X of work coordinates G58 (mm)
- 22, C(Y) of work coordinates G58 (mm)
- 23, Z of work coordinates G58 (mm)
- 24, A of work coordinates G58 (mm)
- 26, X of work coordinates G59 (mm)
- 27, C(Y) of work coordinates G59 (mm)
- 28, Z of work coordinates G59 (mm)
- 29, A of work coordinates G59 (mm)

### **3.3.7 Password**

password setting includes:

- 1, Is enable CNC Co.'s password ?
- 2, Is enable Machine Co.'s password ?  
Original password is "NEWNEW".
- 3, Is enable User's password ?  
Original password is "KERKER".
- 4, Modify CNC Co.'s password:
- 5, Modify Machine Co.'s password:
- 6, Modify User's password:
- 7, carry word time: (days)

### **3.3.8 Pitch error compensation**

It is used for pitch error automatic compensation, due to the effect of screw pitch error on machine transmission accuracy. system adopts store pitch error compensation: when debugging, it measures out the screw error curve based on machine zero point a strating point, makes out revised curve on the basis of error curve, then inputs the revised curve into revised parameters table, and compensates according to this table.

In parameter menu, pressing “Parameter” key enter into:

Man Con		N00000		2012-12-23 14:19	
Basic Parameter		No	Coord(mm)	Value(um)	Program
1, Standby: 0		1)	<320.000>	0	99.TXT
2, Neg-point: 3		2)	<160.000>	0	Instruction code
3, Pos-point: 2		3)	<0.000>	0	G53
4, multiple: 1.000		4)	<-160.000>	0	T0000
5, distance(um): 80000		5)	<-320.000>	0	Machine Status
		6)	<-480.000>	0	M05 M09 M10
					M78 M33 M70
					G00 X100%
					F6000 X100%
					S50 X100%
					Machine Coord
					X 306.156
					Z 90.422
					C 6.000
N-X-axis	J-Z-axis	V-C-axis	Q-A-axis	PartTime	0:0
A-	B-ChePro	C-CLEAR	D-CANCEL	PartNo	21
No Alarm				SPrpm	0

By using cursor key, it enters into basic parameters setting area, selects parameter through up/down arrows, and presses Enter to pop up dialog box of inputting parameters.

The number of compensation point can be set optionally, Compensation parameters include:

Compensation point NO.of reference point.

Com.point NO.of farrest end in negative direction.

Com.point NO.of farrest end in positive direction.

compensation percentage.

interval between compensation point (um) .

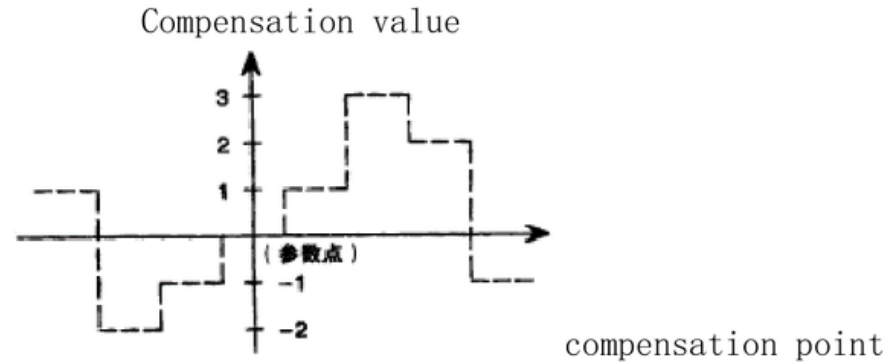

System automatically figures out each axis pitch error compensation point position according to basic parameters. Each axis pitch error compensation point is distributed with equal interval; users can input each point compensation value.

The interval of compenstion point is set on the each axis,  
For example:

Example 1:Linear axis:when length of travel is -400mm ~ +800mm, interval of points 50mm, reference point compensation NO. 40, it can figure out that Com. point NO. of farest end in negative direction is:

Machine negative travel/point interval +1=40-400/50+1=33.

Com. point NO. of farest end in positive direction is:

Machine positive travel/point interval +1=40+800/50=56.

Machine coordinate and compensation point NO. correspondence is:



output compensation value in 0 position

parameters set as follows:

compensation point NO. of reference point:40

Com. point NO. of farest end in negative direction:30

Com. point NO. of farest end in positive direction:56

Compensation percentage:1

Compensation point interval:50000

Compensation point and value contrast:

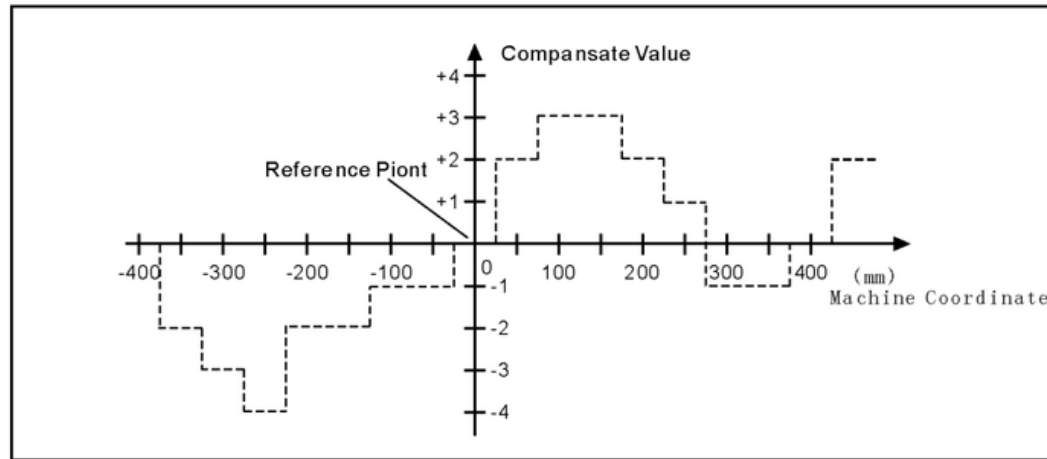

Example 2: rotor axis: when movement per revolution is  $360^\circ$ , interval of points  $45^\circ$ , reference point compensation NO. 60, Com. point NO. of farest end in negative direction is usually same as reference point com. point NO.

Com. point NO. of farest end in positive direction is:

Reference compensation point NO. + movement per revolution/comp point interval =  $60 + 360/45 = 68$ .

Machine coordinate and compensation point NO. correspondence is:

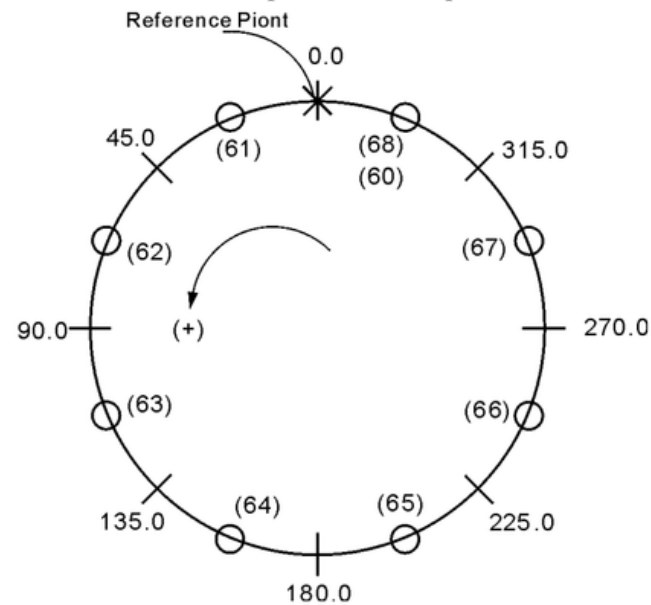

note: input value in small circle. If the total amount from 61 to 68 doesn't equal 0, accumulated pitch error per revolution will deviate, so same value shall be put in 60 and 68.

Parameter sets as follows:

compensation point NO. of reference point: 60

Com. point NO. of farest end in negative direction: 60

Com. point NO. of farest end in positive direction: 68

Compensation percentage:1

Compensation point interval:45000

Output compensation value at corresponding point:

NO.	60	61	62	63	64	65	66	67	68
VALUE	+1	-2	+1	+3	-1	-1	-3	+2	+1

Compensation point and value contrast:

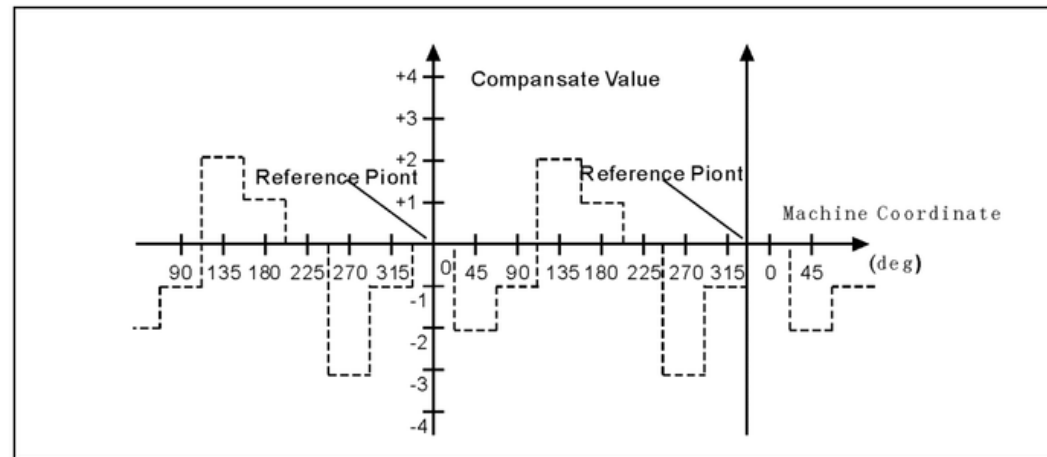

### 3.3.9 Input/output diagnosis

Presses "Diagnosis" key :



Man Con		N00000								2012-12-26 19:28		
Input point										Program	99.TXT	
0	0	0	0	0	0	0	0	0	0	Instruction code		
X00	X01	X02	X03	X04	X05	X06	X07	X08	X09	G53		
T01	T02	T03	T04	T05	T06	T07	T08	M34/A0	-L	T0302		
0	0	0	0	0	0	0	0	0	0	Machine Status		
X10	X11	X12	X13	X14	X15	X16	X17	X18	X19	M05	M09	M10
+L	M36/Y0	X0	Z0	KRUN	KHALT	X20	X21	X22	X23	M78	M33	M70
0	1	1	0	0	0	0	0	0	0	G00	X100%	
X16	X17	X18	X19	X20	X21	X22	X23	X24	X25	F6000	X100%	
X20	Z20	KLEFT	KRIGHT	STOP	TOK	ALM	ALM1	ALM2	M28	S600	X100%	
0	0	0	0	0	0	0	0	0	0	Machine Coord		
X24	X25	X26	X27	X28	X29	X30	X31	X32	X33	X	0.000	
ALM2	M28	M24	M22	M18	M12	M14	M16	HX/DS8	HY/DS4	Z	0.000	
1	1	1	1	1	1	1	1	X34	X35	C	0.000	
HX/DS8	HY/DS4	HZ/DS2	HA/DS0	HX1/K8	HX10/K	HX100/	H0FF/K	X36	X37	PartTime 0: 37		
								X38	X39	PartNo 231		
										SPrpm 0		
										No Alarm		
N-	J-I/O	V-	Q-ALARM									
A-	B-Reset	C-	D-CANCEL									

Man Con		N00000								2012-12-26 19:29		
Output Point										Program	99.TXT	
0	0	0	0	0	0	0	0	0	0	Instruction code		
Y00	Y01	Y02	Y03	Y04	Y05	Y06	Y07	Y08	Y09	G53		
M61	M63	M65	M67	M69	M71	M73	M75	M32	M79	T0302		
0	0	0	0	0	0	0	0	0	0	Machine Status		
Y10	Y11	Y12	Y13	Y14	Y15	Y16	Y17	Y18	Y19	M05	M09	M10
M10	M08	M05	M04	M03	M75	LRUN	INTH	+T	-T	M78	M33	M70
0	0	0	0	0	0	0	0	0	0	G00	X100%	
Y20	Y21	Y22	Y23	Y24	Y25	Y26	Y27	Y28	Y29	F6000	X100%	
S04	S03	S02	S01							S600	X100%	
0	0	0	0	0	0	0	0	0	0	Machine Coord		
Y16	Y17	Y18	Y19	Y20	Y21	Y22	Y23	Y24	Y25	X	0.000	
LRUN	INTH	+T	-T	S04	S03	S02	S01			Z	0.000	
0	0	0	0	0	0	0	0	0	0	C	0.000	
										PartTime 0: 37		
										PartNo 231		
										SPrpm 0		
										No Alarm		
N-	J-I/O	V-	Q-ALARM									
A-	B-Reset	C-	D-CANCEL									

### 3.4 Program

Program management adopts documents management mode, due to NAND FLASH, this system can store 32MB program. user program can be protected by password. Edition is made by full screen mode.

In main interface, press “program” to pop up interface of choosing program.

Man Con				N00000		2012-12-21 19:26	
File/File folde in system				Program		99.TXT	
CurDir: /NC				Instruction code		G53	
92						T0001	
99.TXT				Machine Status		M05 M09 M10	
G31-1						M78 M33 M70	
G31检测Z轴设置T1修正T2T3.TXT						G00 X100%	
G31检测Z轴再运行修正T2T3-1.TXT						F6000 X100%	
G32-2						S50 X100%	
G76				Machine Coord		X 166.000	
G761						Z 161.096	
G93						C 0.000	
MM				PartTime		0: 15	
PROGRAM120				PartNo		17	
砂轮修正补偿程序.TXT				SPrpm		0	
先运行G31检测Z轴设置T1.TXT							
再运行G31检测Z轴设置T2T3.TXT							
Compile-P: Receive-R, Tansmit-T, DNC-L							
N-New/Sek	J-COPY	V-RENAM	Q-INFOR				
A-LAST	B-USBdisk	C-EXEC	D-CANCEL				
No Alarm							

Center part of screen for program display, current program is showed by reverse display, move PgUp、PgDn to choose program, and then press “Enter” to edit current program. Functional keys “N、J、V、Q、A、B、C、D” include: “new file/search”、“copy”、“rename”、“information”、“last grade” “USB disc”、“execute program”、“cancel”.

#### 3.4.1 new file/search

when this button is pressed, it pops up the requirement to input the name of new/searched documents, it can be number, letter (no difference if it is capital letter or small letter) or other mixture of symbol

(not include / \ : \* ? “ < > | and ), no limitation on length. Input document name, then press “enter” to confirm. if it exists in system, it will be found and reversely displayed, if not, it will be newly build and reversely diaplayed. To build a new file.

### **3.4.2 copy**

it is reduplicating current program to another program. Choose this item to pop up dialogue box, input new document name, if it exists, input is invalid, if not, this name will be the name of newly copied document.

### **3.4.3 rename**

for convenience of management, the original documents can be renamed. Choose this item to pop up dialogue box, input new document name, if it exists, input is invalid, if not, this name will be the name of original document.

### **3.4.4 delete**

“Del” for deleting all content and name of current program.

### **3.4.5 infomation**

This system provides users information column for each program, which is convenient for users to amend and set.  
Length of document (uneditable)  
Last time of document amending (uneditable) .

### **3.4.6 USBdisc**

Press “B” open or close U disk.

note: before pulling out U, it must return to directory of doc name. otherwise newly copied data in U may lose.

### **3.4.7 Serial port transmission program**

Besides U, can use RS232 port. In interface of choosing program, press R to receive program, press T to send program:

Then can communicate the program according to the interface. The following chart shows:

Transmit the program file from PC to CNC:run CNC CO.’ s special series communication software on PC . Clicks the “transmits the CNC

program file" button and select , clicks the "turns on" button, now PC is waiting for transmitting; presse "R" under the "program" interface, keys in the program filename. The PC begins to transmit.

Transmit the program file from CNC to PC: presses the key "↑" "↓" to select the program filename under the interface of "program" , then presse "T", now the system is waiting for transmitting; Run CNC CO.'s special series communication software in PC. Click the "receives the CNC program file" button, key in the program filename in the dialog box, clicks on the "save" button, now the system begins to transmit the program file.

### 3.4.8 editing

Man Con				数控机床 N00000		2013-01-24 13:35	
/NC/99.TXT				Program 92			
N1 M03 S600				Instruction code			
N2 G00 X200 Z200				G54			
N3 W-5				T0202			
N4 G01 U4 W-2 F300				Machine Status			
N5 W-11				M05 M09 M10			
N6 U-4 W-2				M78 M33 M70			
N7 W-5				G00 X100%			
N8 U10 W-10				F6000 X100%			
N9 W-6				S0 X100%			
N10 G02 U-6 W-9 I12 K-9				Machine Coord			
N11 U10 W-15 I25 K0				X 0.000			
N12 G03 U0 W-30 I-20 K-15				Z 0.000			
Press Rapit Key No.3 /Total134				C 0.000			
N-COMPIL		J-FrELine		V-TeachIn		Q-POS	
PartTime 0: 1		A-		B-DeLLine		C->>	
PartNo 0		D-CANCEL		SPrpm 0			
No Alarm							

The edition mainly uses to edit, insert, modify, delete and so on. After selects the program name and enter the entire screen edition system. The menu at the base of the screen includes (press "RAPIT" + "N、J、V、Q、B、C、D") "compile", "first line", "Teaching", "pose", "del line", ">>" ("del block" "copy block" "array" "serch" "alter" "aalter" "<<"), "cancel", etc.

Users can operate at the area of line number at the left side of the screen.

The program name to edit and the line number to point were clue at the top of the screen.

1) **pose the cursor:** change the cursor' s position

" ↑ ↓ " the cursor moves up or down

" -> < - " The cursor shifts to left or right

"PgUp.PgDn "the cursor goes to last page or next page.

"Enter", to the next line.

press "pose" and key in line number can locate directly to the line which you key in.

Press "first line" locate directly to "the first line".

press "endline" locate directly to the end line.

When the located program line surpasses the page, it will automatically change to the next page and the located program line will be contained in the display .

2) **insert:** key in the insertion in front of the cursor, if they are letters, it will automatically produces blank space.

3) **delete:** presses "Del" can delete the character at the back of the cursor.

4) **shift KEY:** presse twice key in the shift character.

5) **delete line :**press "RAPIT+delete line" to delete the line.

6) **operate the block :** Contains copy block and delete block.

7) **compile:** compile the source program (ISO code) to the computer code procedure.

show error when compile, or show "OK" .

When enters the automatic main function, this system automatically carries on concealed compiling process .If there' s a mistake, the system clues on the error message.

"compile" includes " compile NC" and " compile MAC".

8) **search:** Uses to search the appointed character string.

9) **replace:** "alter" Uses to replace the appointed character string.

10) **all replace:** "aalter" Use to replace all appointed character string from the cursor to the ending of the program

press "Emergency brake" can stop carrying on " search", " alter", "all alter".

11) **exit:** press "Esc" or F8 returns to the main interface and save the program automatically.

### 3.4.9 Select the machining procedure

Select the machining procedure before the automatically machining.  
The operating procedure is: Press "↑" "↓" to select the program  
and press "execute" ("C" key).

## 3.5 Manual

### 3.5.1 Continual mode

Continuous operation is based on the time of pressing down the keys,  
press down to, By using the keys "+X, -X, +Y, -Y, +Z, -Z, +4, -4" in the  
panel to make feed in the selected axis, feed speed equals handle speed  
times speed percentage.

When feed moves over the two hard limit points of the operating axes,  
it will stop, at this time it can only move reversely.

### 3.5.2 Increment

The increment way operation means set a increment with the keys "+X,  
-X, +Y, -Y, +Z, -Z, +4, -4". feed speed equals handle speed times speed  
percentage.

Presses the key  to change the increment. When feed moves over  
the two hard limit points of the operating axes, it will stop, at this  
time it can only move reversely. Presses "I" change increment value.

### 3.5.3 Handwheel pulse generator

Users can select the axis X, Y, Z and the fourth axis, and can select  
percentage X1, X10, X100. When you use it the green light at the right side  
of the interface lights up.

### 3.5.4 Back to the reference points

Going back to the reference points means to move each axis to  
machine datum point switch. When axis inspects the datum point signal,  
it will set the parameter as datum point data in accordance with the  
preferential reference points.

At the manual condition, presses  and select X, Y, Z, 4, A to go back  
to the reference point. When chooses X, Y, Z, 4, only returns to this

axis the reference point. Chooses A, returns to the reference point in turn.

Presses "stops" returns to the reference point.

### 3.5.5 Other operation at the manual conditions

#### 1) manual main axle condition:

Press  the principal axis veer, display M03.

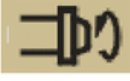
Press  the principal axis reverse, display M04.

Press  the principal axis stop, display M05. At this condition, users can press the key to turn off or turn on.

Press  M03 turn on point for while.

Press  the coolant to turn on or turn off.



Press  SP chuck to turn on or turn off.

Press  in choosing the position cutting tool.

Presses  thumbstall to turn on or turn off.



#### 2) Adjust the feed speed:

The feed speed percentage can be controlled by the wave band

switch or the key  , the percentage increases or decreases 10%. The scope is 0 -150%, 16 grades in all.

#### 3) Control the principal axis speed:

The main axle speed percentage can be controlled by the wave band

switch or the key  , the percentage increases or decreases 10%. The scope is 0 -150%, 16 grades in all.

4) presses "stops": Stops the manual operation.

5) presses "F", there' s a dialog box used to alter the manual feed speed. That is convenient for cutting by single axis.

6) presses "S", alter the principle axis' s revolving speed.

7) presses "T", choosing the position cutting tool.

### 3.5.6 Tool setting

Tool setting is essential in operation. When two and more tools are required, tool setting is needed. To make accuracy, please follow the following steps:

#### Method 1:

- 1, tighten workpiece roughcast, choose proper spindle rotation and feed speed. Start spindle.
  - 2, select the tool which is to be set, such as: T0101.
  - 3, cut a short of excircle or hole in the continuous mode.
  - 4, stop feed, press "Tool" to store the current cutting point coordinates.
  - 5, X, Z axes withdraw, turn off spindle.
  - 6, measure workpiece' s diameter.
  - 7, input the measured values into X value box, "enter" to confirm. If the tool is beyond the center of spindle, input negative value. Press "PgUp" to choose the previous tool, and "PgDn" to next tool.
  - 8, likewise, cutting the head face of roughcast.
  - 9, measure the distance between the head face and spindle collet.
  - 10, press "tool", input the measured values into Z value box.
- At this time, T0101 tool has finished its setting. Repeat steps 1-10 to set other tools.

#### Method 2:

- 1, tighten workpiece roughcast, choose proper spindle rotation and feed



speed. Start spindle.

2, select the tool which is to be set, such as: T0101.

3, cut a short of excircle or hole in the continuous mode.

4, Z axis withdraws (X axis can not move), turn off spindle.

5, measure workpiece' s diameter.

6, press “tool” , input the measured values into X value box, “enter” to confirm. If the tool is beyond the center of spindle, input negative value. Press “PgUp” to choose the previous tool, and “PgDn” to next tool.

7, likewise, cutting the head face of roughcast.

8, measure the distance between the head face and spindle collet.

9, press “tool” , input the measured values into Z value box.

At this time, T0101 tool has finished its setting. Repeat steps 1-9 to set other tools.

### 3.6 automatic

          Cancels manual and turnes to automatical,The system compile the procedure automatically,it can show the error.

#### 3.6.1 coordinates

          The coordinates running show the tool' s position.It can shows the

workpiece coordinates and the compositive coordinates. Shifted by



key.

#### 3.6.2 graphics mode

          The graphics running status means the tool path is displaying by the graphic method.Operator may rotate or translate graphics through the cursor key,and may enlarge or shorten the graphics Through PageUp, PageDn key. By the Q key can returns to the initial graph status. Furthermore, we can look at the entire tool track before the machining. under the runing or stop state operator can switch the coordinates/Graphics status, the coordinates/graphics switch key is



### 3.6.3 continuously mode

The continuous running state means the program unceasingly executes section after section.

### 3.6.4 Step mode

The Step mode means only runs the current program section, then waits for pressing running button.

under the running or hold or stop state operator can switch the step/Continual status, step/continual switch key is .

### 3.6.5 simulations

Under the status of simulation when presses key , After pressing the "run" button, program run by path graphic mode or coordinate mode. But all axes and other machine motion will be stopped.

### 3.6.6 Keep feed status

Under the program hold status, pressing "Manual" soft key can enter keep feed status, at this time, we can execute manual operate by manual continuously, manual increase, handwheel. Afterward, cancel "Manual" status and pressing the "run" button, CNC will move to the holding point by the speed of default G01/G02/G03. First move Z axis if forward, otherwise backward, other axis moving sequence is X->Y->A.

### 3.6.7 M D I method

When presses down the "MDI" soft key, CNC would spring the MDI dialog box, After input NC code, pressing "run" key, The CNC will carry out this section of program immediately.

### 3.6.8 Begin from program some actual line

Pressing the "-" key, CNC will break out a dialog box, after input actual line number and press the "run" key, CNC will execute program from the input line.

Specially pay attention: The CNC will first move to begin line

point according speed of default G01/G02/G03, after all, begin to execute program.

### **3.6.9 Begin from program some mark line**

Pressing the "N" key, CNC will break out a dialog box, after input mark line number and press the "run" key, CNC will execute program from the input line.

Specially pay attention: The CNC will first move to begin line point according speed of default G01/G02/G03, after all, begin to execute program.

### **3.6.10 Begin from program some tool number**

Pressing the "G" key, CNC will break out a dialog box, after input mark tool number (example:T0101 must input 01) and press the "run" key, CNC will execute program from the input tool number.

Specially pay attention: The CNC will first move to begin line point according speed of default G01/G02/G03, after all, begin to execute program.

### **3.6.11 Set coordinates/Choice coordinates**

Set coordinates:

The Set coordinates is used for configure any work coordinate or the relative coordinates value. Under the work coordinate display mode configure work coordinate; Under the synthesis coordinate display mode configure relative coordinate, in the course of program running also can configure relative coordinate.

Note: The machine coordinates cannot be configured.

Choice coordinates:

After pressing "MDI" input G53/G59 may choose G53, G54, G55, G56, G57, G58, G59 work coordinate. Corresponding work coordinate status is displaying in the top right corner interface.

### **3.6.12 large capacity molds program**

Because this CNC have 32MB flash for saving user NC program, therefore the NC program can not longer 32MB. At the same time, if the program is larger than 3000 lines, cannot use G22 and other cycle instruction.

### 3.7 Tool redeem

Presses “Redeem” :

Man Con		N00000		2012-12-21 19:27																																									
<table border="1"> <tr> <td>01</td> <td>X: 0.000</td> <td>Z: 0.000</td> <td>C: 0.000</td> <td>A</td> </tr> <tr> <td>02</td> <td>X: 0.000</td> <td>Z: 0.000</td> <td>C: 0.000</td> <td>A</td> </tr> <tr> <td>03</td> <td>X: 0.000</td> <td>Z: 0.000</td> <td>C: 0.000</td> <td>A</td> </tr> <tr> <td>04</td> <td>X: 0.000</td> <td>Z: 0.000</td> <td>C: 0.000</td> <td>A</td> </tr> <tr> <td>05</td> <td>X: 0.000</td> <td>Z: 0.000</td> <td>C: 0.000</td> <td>A</td> </tr> <tr> <td>06</td> <td>X: 0.000</td> <td>Z: 0.000</td> <td>C: 0.000</td> <td>A</td> </tr> <tr> <td>07</td> <td>X: 0.000</td> <td>Z: 0.000</td> <td>C: 0.000</td> <td>A</td> </tr> <tr> <td>08</td> <td>X: 0.000</td> <td>Z: 0.000</td> <td>C: 0.000</td> <td>A</td> </tr> </table>				01	X: 0.000	Z: 0.000	C: 0.000	A	02	X: 0.000	Z: 0.000	C: 0.000	A	03	X: 0.000	Z: 0.000	C: 0.000	A	04	X: 0.000	Z: 0.000	C: 0.000	A	05	X: 0.000	Z: 0.000	C: 0.000	A	06	X: 0.000	Z: 0.000	C: 0.000	A	07	X: 0.000	Z: 0.000	C: 0.000	A	08	X: 0.000	Z: 0.000	C: 0.000	A	Program <input type="text" value="99.TXT"/>	
01	X: 0.000	Z: 0.000	C: 0.000	A																																									
02	X: 0.000	Z: 0.000	C: 0.000	A																																									
03	X: 0.000	Z: 0.000	C: 0.000	A																																									
04	X: 0.000	Z: 0.000	C: 0.000	A																																									
05	X: 0.000	Z: 0.000	C: 0.000	A																																									
06	X: 0.000	Z: 0.000	C: 0.000	A																																									
07	X: 0.000	Z: 0.000	C: 0.000	A																																									
08	X: 0.000	Z: 0.000	C: 0.000	A																																									
				Instruction code																																									
				<input type="text" value="G53"/>																																									
				<input type="text" value="T0001"/>																																									
				Machine Status																																									
				<table border="1"> <tr> <td>M05</td> <td>M09</td> <td>M10</td> </tr> <tr> <td>M78</td> <td>M33</td> <td>M70</td> </tr> </table>		M05	M09	M10	M78	M33	M70																																		
M05	M09	M10																																											
M78	M33	M70																																											
				<table border="1"> <tr> <td>G00</td> <td>X100%</td> </tr> <tr> <td>F6000</td> <td>X100%</td> </tr> <tr> <td>S50</td> <td>X100%</td> </tr> </table>		G00	X100%	F6000	X100%	S50	X100%																																		
G00	X100%																																												
F6000	X100%																																												
S50	X100%																																												
				Machine Coord																																									
				<table border="1"> <tr> <td>X</td> <td>166.000</td> </tr> <tr> <td>Z</td> <td>161.096</td> </tr> <tr> <td>C</td> <td>0.000</td> </tr> </table>		X	166.000	Z	161.096	C	0.000																																		
X	166.000																																												
Z	161.096																																												
C	0.000																																												
<input type="button" value="N-Radius"/>		<input type="button" value="J-Length"/>		<input type="button" value="V-ACLEA"/>																																									
<input type="button" value="Q-CLEAR"/>		<input type="button" value="A-SetTool"/>		<input type="button" value="B-ToolPoit"/>																																									
<input type="button" value="C-Set"/>		<input type="button" value="D-CANCEL"/>		PartTime <input type="text" value="0: 15"/>																																									
No Alarm				PartNo <input type="text" value="17"/>																																									
				SPrpm <input type="text" value="0"/>																																									

Presses N, set tool' s radius.

Presses J, set tool' s redeem.

Presses V, clear all value.

Presses Q, clear current tool value.

Presses A, tool posit.

Presses B, G41/G42 compensation parameter.

Presses C, set tool' s number.

Presses D, cancel.

## Chapter4 Programming

Programming refers to process of using cnc language to describe machining track and actions based on the machining blueprint and technique requirement.

### 4.1 basic concepts

**program segment:** is a complete command line consisted of instruction segment and data segment.

**Program:** is a congregation of program segment by machining logic structure in order to complete the machining of workpiece.

**Machine coordinate system:** see fig Lathe top view.

Machine coordinate stipulates machine coordinate and direction, z axis parallels spindle, direction away from spindle is positive. X axis is vertical to spindle, the opposite of knifepoint is positive.

#### Lathe top view

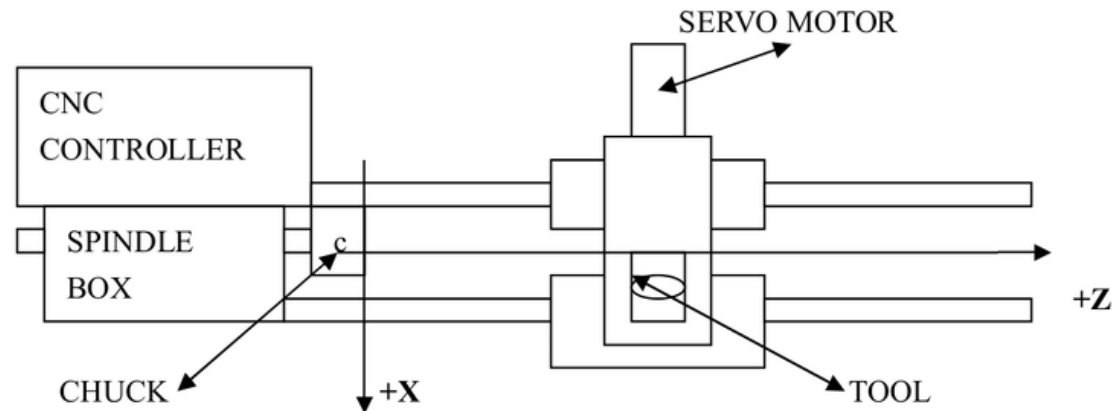

**Absolute programming:** it is confirmed coordinates data programming mode based on established absolute coordinate system. X, Z stand for it.

**Relative programming (increment programming):** is the distance and direction of operation end point, compared with starting point. U, W stand for it.

**Mixed programming:** is the programming of one segment program by both absolute programming and relative programming.

**Diameter programming:** all X axis coordinate are presented by diameter.

**Starting point:** the place where the tool begins to move when program starts.

**Name of program:** the name of machining program.

**Mode instruction:** the instruction which can remain the function in the program. It works both in this program and program in the future.

In the same operation, there may be several mode instruction, such as M03 (spindle clockwise), M04 (spindle counter clockwise), M05 (spindle stop). They are all Mode used to control spindle. The mode of same kind are categorized into one mode group. At any time it must be one of them, and there is only one of them. The original chosen mode instruction is called mode origin. In the above mode group, M05 is such a mode origin.

**Suspending mode (destroying mode):** is the instruction which can turn mode instruction into mode origin or destroy the mode. Such as M20 (program ending instruction), meaning the end of operation and returning to original status.

**Non mode instruction:** is the instruction which has no function to store, and only works in the segment of program.

## 4.2 Program instruction

### 4.2.1 Functional meaning of address symbol, data list.

Functions	Address symbol	Meaning	Data range
Program segment No	N	No of program segment	
Preparation function	G	Content and mode of designated instruction operation	00-99
Auxiliary function	M	Auxiliary operation instruction	00-99
Tool function	T	Tool changing instruction	Tool T0101-9999
Spindle function	S	The first spindle speed	0-65000
Spindle function	SS	The second spindle speed	0-65000
Cutting speed	F	Speed per minute, per rotation	1-30000mm/min, 0.001-9.999mm/n

Coordinates character	XU ZW	The coordinates value of X Z axes	$\pm 99999.9999\text{mm}$
Lead of screw thread	F(I)	F for metric, I for imperial	0.1-1000mm, 1-99teeth/inch
Core coordinates	IK	X Z axes coordinate increment value	$\pm 99999.9999\text{mm}$
Arc radius	R	Arc radius value, tool radius value	0.001-99999.999mm
Delay time	XUP	Delay time of designated delay	0.001-65s
Program entrance	P	Entrance of calling program segment	0000-99999
Repeat times	L	Times of cycle or subprogram calling L can be used as numbers of multiply screw thread	1-65000 1-99
Program skip	/	There is “/”befor N, this line does not run.	

#### 4.2.2 Program instruction table

Group	Nature	Code	Functions	Origin	Mode	remarks
1	Main control functions	G00	Rapid point positioning	√	√	
		G01	Linear interpolation		√	
		G02	Circular—clockwise		√	
		G03	Circular—counterclockwise		√	
		G32	spiral interpolation			
		G332	G02 spiral			
		G333	G03 spiral			
		G31	Check jump No alm			
G311	Check jump alm					

Loop command	G70	Finish machining loop		✓		
	G71	Cylindrical face thick loop		✓		
	G72	end face thick loop		✓		
	G73	close loop		✓		
	G74	end face deep hole loop		✓		
	G75	slot loop		✓		
	G76	complex screw thread loop		✓		
	G90	Circular loop		✓		
	G92	screw thread loop		✓		
	G93	tap loop		✓		
	G94	end face loop		✓		
	G22	loop end		✓		
	G800	cancel loop		✓		
	Go start	G26	Z、X go start			
		G261	X go start			
G262		Y go start				
G263		Z go start				
G264		A go start				
Go G25	G61	XZ Go G25				
	G611	X Go G25				
	G612	Y Go G25				
	G613	Z Go G25				
	G614	A Go G25				
Save	G25	Save current coor		✓		
Go home	G28	XZ go home				
	G281	X go home				
	G282	Y/C go home		✓		
	G283	Z go home				
	G284	A go home				
	M800	C go encode Zero				
e	G50	Setup coor system		✓		



		G52	Setup part coor ststem		√	
		G184	Setup current Tool coor			
		G185	Setup all Tool coor			
2	line	G96	Constant line speed cutting		√	
		G97	cancel	√	√	
	feed	G98	Set feed per minute	√	√	
		G99	Set feed per revolution		√	
	mode	G15	cancel	√	√	
		G16	bally coor program		√	
		G21	metric program	√	√	
		G20	imperial		√	
3	delay	G04	Programmed dwell			
4	cut	G60	Nicety stop	√	√	
		G64	Continuum part		√	
5	compensation	G40	Cancel cutter compensation	√	√	
		G41	Cutter in the left of workpiece		√	
		G42	Cutter in the right of workpiece		√	
6	Work coor	G53	Machine coor	√	√	
		G54	Work coor1		√	
		G55	Work coor 2		√	
		G56	Work coor 3		√	
		G57	Work coor 4		√	
		G58	Work coor 5		√	
		G59	Work coor 6		√	
7	SP	M03	Spindle on clockwise		√	
		M04	Spindle on		√	

		M05	counterclockwise Spindle off	✓	✓	
8	Cooling	M08 M09	Coolant on Coolant off	✓	✓ ✓	
9	Chuck	M10 M11	Chuck tightens Chuck loosens	✓	✓ ✓	
10	Tailstock	M79 M78	Tighten Loose	✓	✓ ✓	M79
11	Lubrication	M32 M33	Lubrication on Lubrication off	✓	✓ ✓	M32
12	Huff	M59 M58	Huff on Huff off	✓	✓ ✓	M59 output
12	user-define output	M61 M60	user-define1		✓ ✓	M61 output
		M63 M62	user-define2		✓ ✓	M63 output
		M65 M64	user-define3		✓ ✓	M65 output
		M67 M66	user-define4		✓ ✓	M67 output
		M69 M68	user-define5		✓ ✓	M69 output
		M71 M70	user-define6		✓ ✓	M71 output
		M73 M72	user-define7		✓ ✓	M73 output
		M75 M74	user-define8		✓ ✓	M75 output
		13	Input	M12 M13	Check M12 valid Check M12 invalidate	

		M14	Check M14 valid		✓	
		M15	Check M14 invalidate		✓	
		M16	Check M16 valid		✓	
		M17	Check M16 invalidate		✓	
		M18	Check M18 valid		✓	
		M19	Check M18 invalidate		✓	
		M28	Check M28 valid		✓	
		M29	Check M28 invalidate		✓	
		M22	Check M22 valid		✓	
		M23	Check M22 invalidate		✓	
		M24	Check M24 valid		✓	
		M25	Check M24 invalidate		✓	
14	SP Gear	M41	first gear			
		M42	second gear			
		M43	third gear			
		M44	fourth gear			
15	Jump	M97	jump			
		M98	call			
		M99	return			
16	Program	M00	pause			
		M01	M22 availpause			
		M02	Program end			
		M30	M05、M09 end			
		M20	Loop go start			
17	SP speed	S	First SP		✓	S=0-65000
		SS	Second SP		✓	SS=0-65000
18	Tool	Tab	A:xx B:xx		✓	A、b=00-12

## 4.3 Preparation functions

### 4.3.1 Programming stipulation

1, multiply instruction exist in a segment simultaneously: one program line allows multiply instructions in order to reduce the lines, but the same group of instruction can not share one segment.

2, within a program segment, instruction and parameters can be arranged optionally.

Such as: G01 U10 W-30 can be written: U10 G01 W-30

3, no repeat of instruction within a program segment.

4, no irrelative parameters and operation in a segment.

5, "0" before a instruction is allowed to delete, such as: G01 G03 can be written as G1 G3.

6, the command of optional point, line start or that after tool changing instruction must be programmed by absolute coordinates.

### 4.3.2 Instructions

#### (1) Rapid motion(G00)

Tool move to instructive postion according to G00 speed in paramter.

As absolute method, use section end point coordinate to program;

As increase method, use motion distance to program.

Format: G00 X/U- Y/V- Z/W- A- (Mode, original)
--

Note: X, Y, Z, A means motion axis. The data point out motion distance and direction by absolute or increase method.

G00 move to aim point according to line way.

Moving speed is determined by paramter.

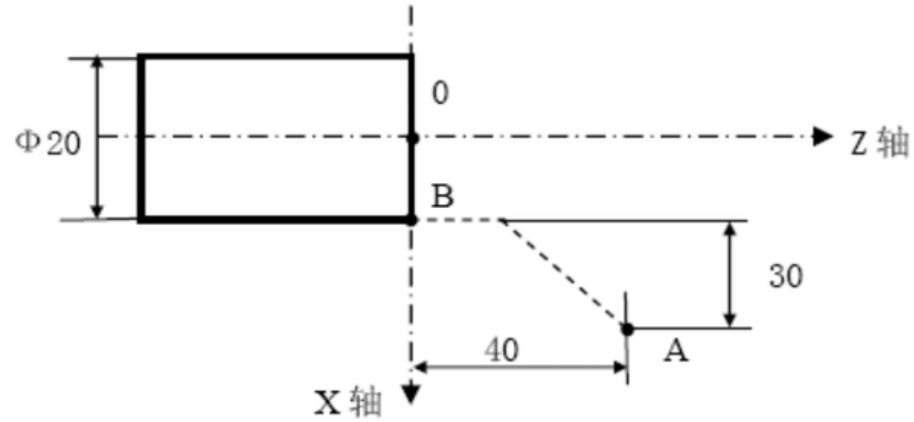

Example: from A to B.

Absolute program: G00 X20 Z0;

Relative program: G00 U-60 W-40;

## (2) Line interpolation(G01)

Used for single axis motion or 2,3,4 axis interpolation motion.

Format: G01 X/U- Y/V- Z/W- A- F- (Mode)

Note: X, Y, Z, A means motion axis. The data point out motion distance and direction by absolute or increase method. Motion speed is determined by F word. The F instuction is mode.

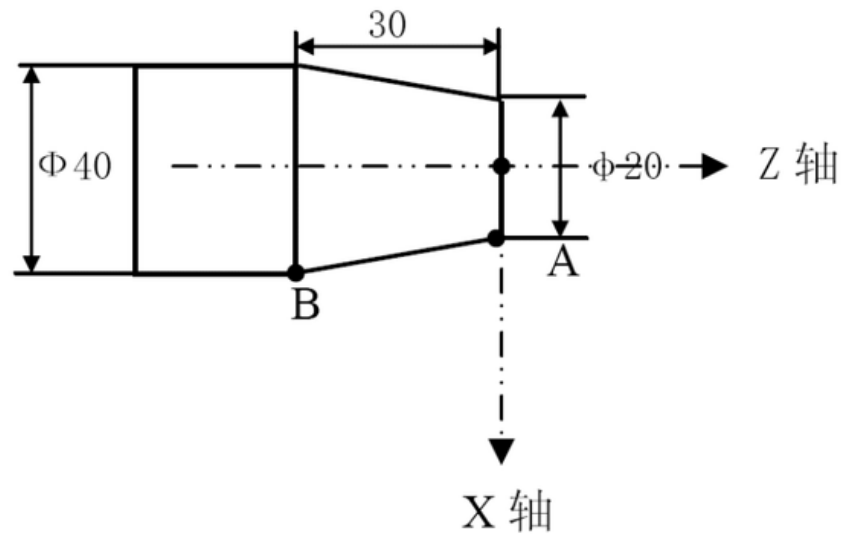

Example: from A to B.

Absolute program: G01 X40 Z-30 F100

Relative program: G01 U20 W-30 F100

### (3) Arc interpolation(G02/G03)

G02 stands for Circular clockwise interpolation, and G03 for Circular counterclockwise interpolation. I is the 2 times of increment of X axis which starting point to center of circle (needless to double it when X axis is radius programming), K is the increment of Z axis which starting point to center of circle, and X Z are the terminal coordinates. It can be also programmed by R not IK.

Format:

G02 X (U) \_\_ Z (W) \_\_ I\_\_ K\_\_ F\_\_;

G03 X (U) \_\_ Z (W) \_\_ I\_\_ K\_\_ F\_\_;

G02 X (U) \_\_ Z (W) \_\_ R\_\_ F\_\_;

G03 X (U) \_\_ Z (W) \_\_ R\_\_ F\_\_;

前刀架系统

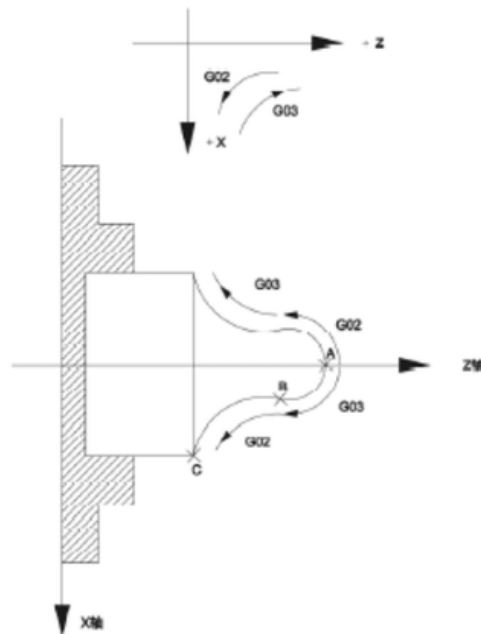

后刀架系统

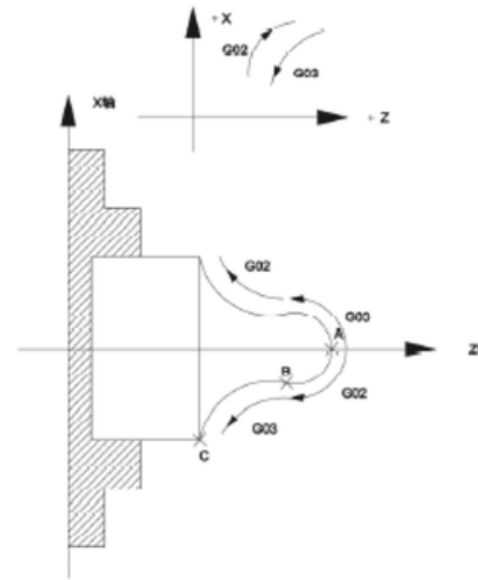

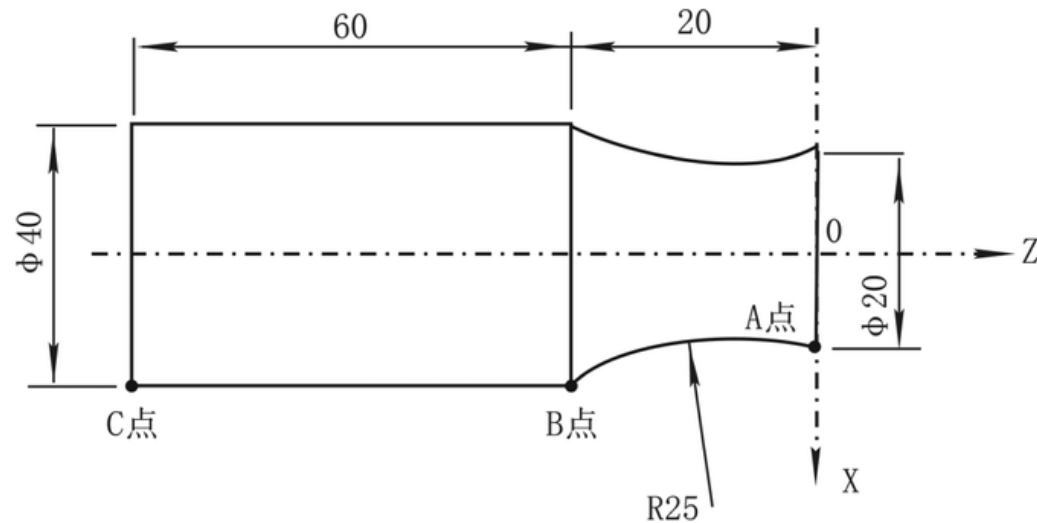

Example: from A to B.

Absolute program: G02 X40 Z-20 I25 K0 ;

Relative program: G02 U20 W-20 I25 K0 ;

R program: G02 X40 Z-20 R25 ;

G02 U20 W-20 R25 。

#### (4) Screw thread (G32)

Format: G32 Z (W) - X (U) - F (I) - SP-

G32 is the spiral interpolation machining instruction. Z/W is the length of Z axis, it cuts strait thread; X/U is the length of X axis, it cuts head face thread; F is metric lead, range is 0.1-1300mm; I is imperial lead, range is 1-99 teeth/inch; L is multiple thread head numbers, range is 1-999, default value is 1.

The use of thread machining instruction must be under the condition that machine has quipped with photoelectric encoder; otherwise the system is in the status of standby. When spindle rotates clockwise, it machinings plus thread in the Z axis negative direction, and left-hand thread in positive direction. The cutting feed speed  $F=KxN$  is appropriate to the machining thread, overhigh speed will destroy the teeth, this system requires  $N \leq 2000n/min$ ,  $F \leq 3000mm/min$ .

For example:

Strait thread: N0000 G32 W-30 K1.5 ; strait thread of length 30, lead 1.5

Metric thread: N0000 G32 W-30 I10.2 ; thread of each inch 101/2

Head face thread: N0000 G32 U-50 K2 ; thread of length 50, lead 2

If rough or fine machining is needed, it can add fine machining rotating speed into thread fine machining instruction.

For example1:

```
N0000 T0101 S1200      ; T1 is tool for rough machining, rotating
                        speed is 1200
N0010 G00 U-1          ; advance of tool
N0020 G32 W-30 K1.5    ; rough machining
```

For example2:

```
G00 U-62.0;
G32 W-74.5 F4.0;
G00 U62;
W74.5;
U-64;
G32 W-74.5;
G00 U64.0;
W74.5;
.....
```

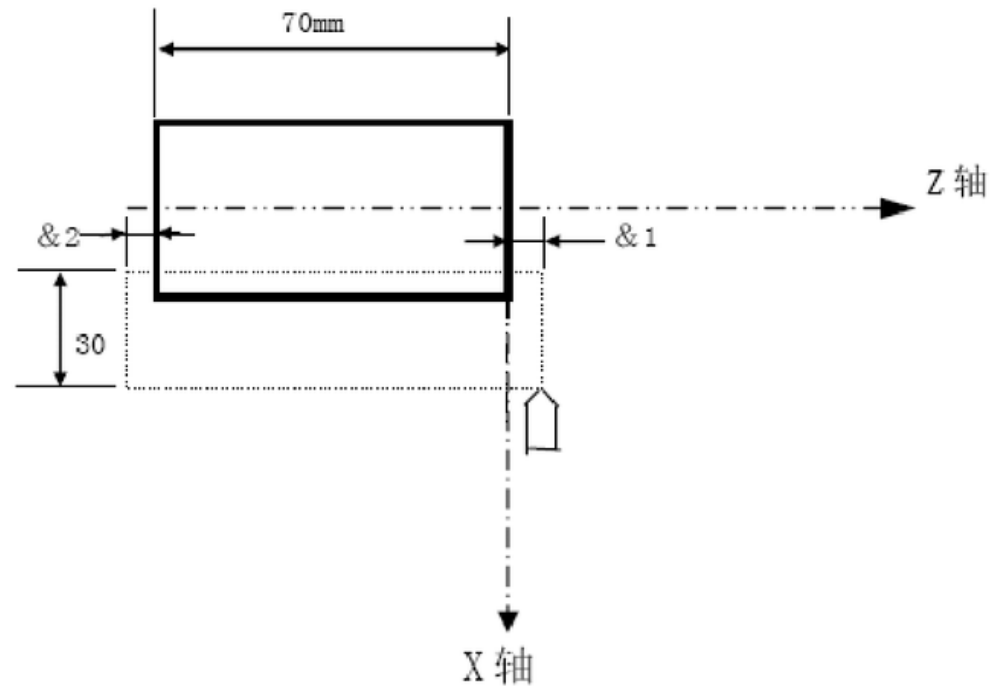

For example3:

```
G00 X12 Z3.0;
G32 X41.0 Z-41.5 F3.5;
G00 X50;
Z3;
```



```

X10;
G32 X39 Z-41.5;
G00 X50;
Z3;
.....

```

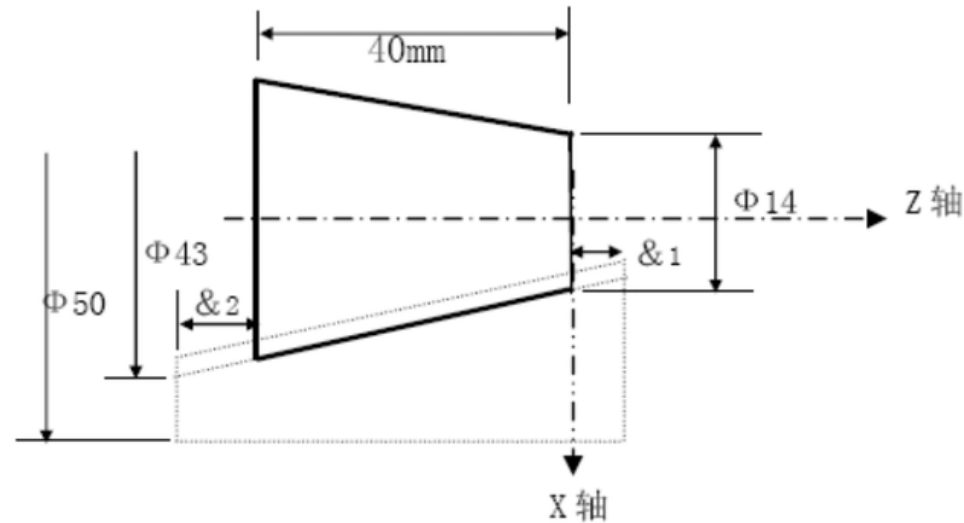

### (5) Circularity screw thread(G332、G333)

Format: G332/G333 Z (W) - X (U) - R - F (I) - SP-  
Use method refer G02、G03、G32instruction.

### (6) delay Instruction(G04)

Require of work process, delays some time before execute other motion.

Format: G04 P\_ X\_ U\_

P word unit ms, means delay time.

X word unit S, means delay time.

U word unit S, means delay time.

For example:

G04 X1;      delay 1s.

G04 P1000;    delay 1s.

G04 U1;      delay 1s.

**(7) Return Refernce(G28/G281/G282/G283/G284)**

Return Refernce instruction means tool go to reference point according to appointed axis.

format:	G28 X/UY/VZ/W;ZXY return to reference
	G281 ;only X return to reference
	G282 ;only Y return to reference
	G283 ;only Z return to reference
	G284 ;only A return to reference

**(8) Setup workpiece coordinate system (G50)**

Format: G50 X (x) Z (z) ;

**(9) Column or taper loop(G90)**

Column loop format: G90 X(U) \_\_ Z (W) \_\_ F\_\_;

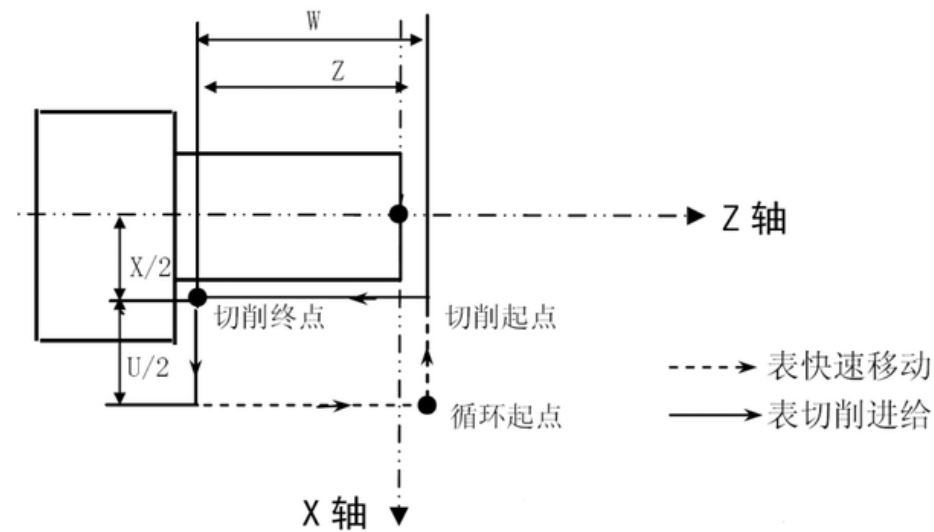

Column loop cotting

For example:

```

N10 T0101;
N20 G00 X55 Z4 M03;
N30 G01 Z2 F100 M08;
N40 G90 X45 Z-25;
N50 X40;
N60 X35;
N70 G00 X100 Z100;
N80 T0100 M09;
N90 M05;

```

N100 M30;

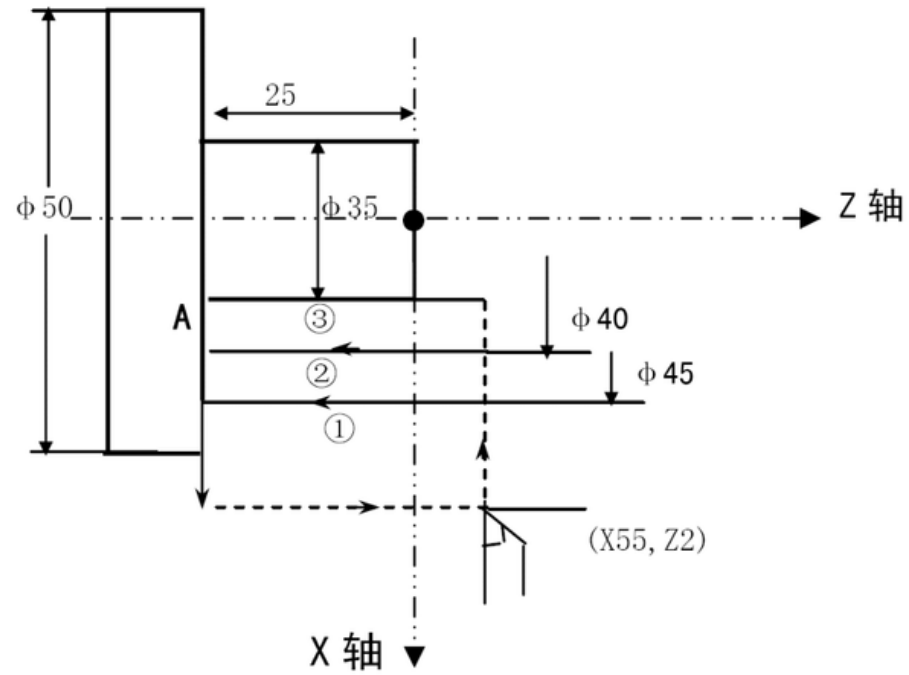

Taper loop format: G90 X(U) \_\_ Z (W) \_\_ R \_\_ F \_\_;

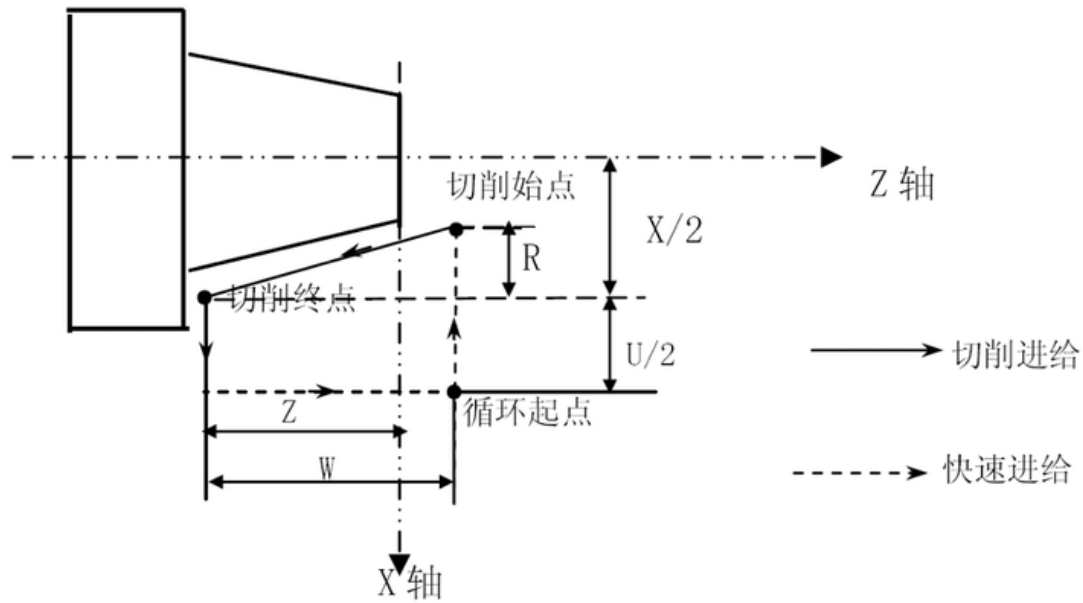

Taper loop cutting

For example:  
 N10 M03 S1000;  
 N20 T0101;  
 N30 G00 X65 Z5;  
 N50 G96 S120;

```

N60 G99 G01 Z2 F1 M08;
N70 G90 X60 Z-35 R-5 F0.2;
N80 X50;
N90 G00 G98 X100 Z100 M09;
N100 G97 S1000 T0100;
N110 M05;
N120 M30;
    
```

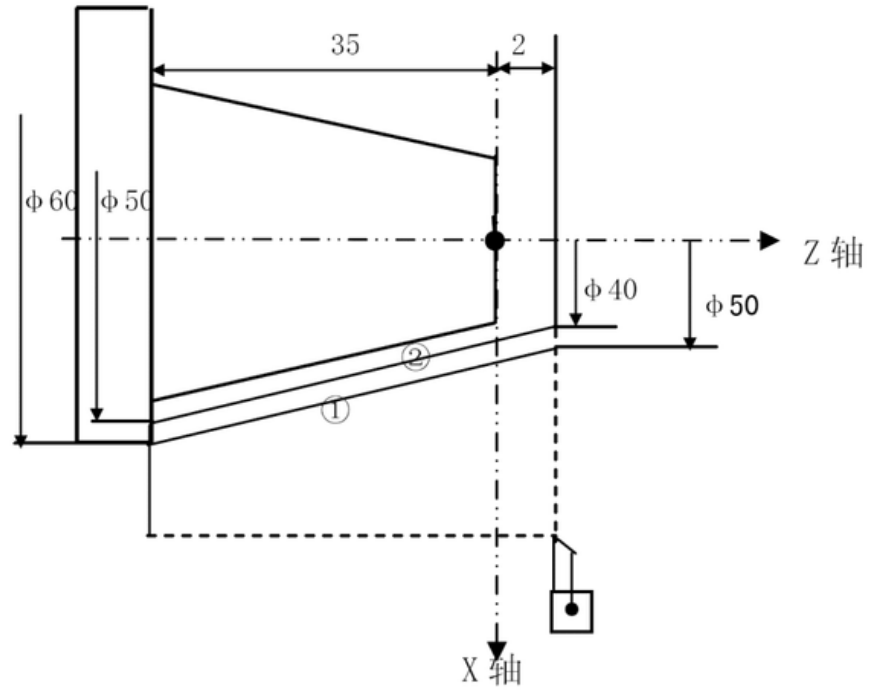

### (10) End face loop(G94)

Format: G94 X(U) \_\_ Z (W) \_\_ F\_\_;

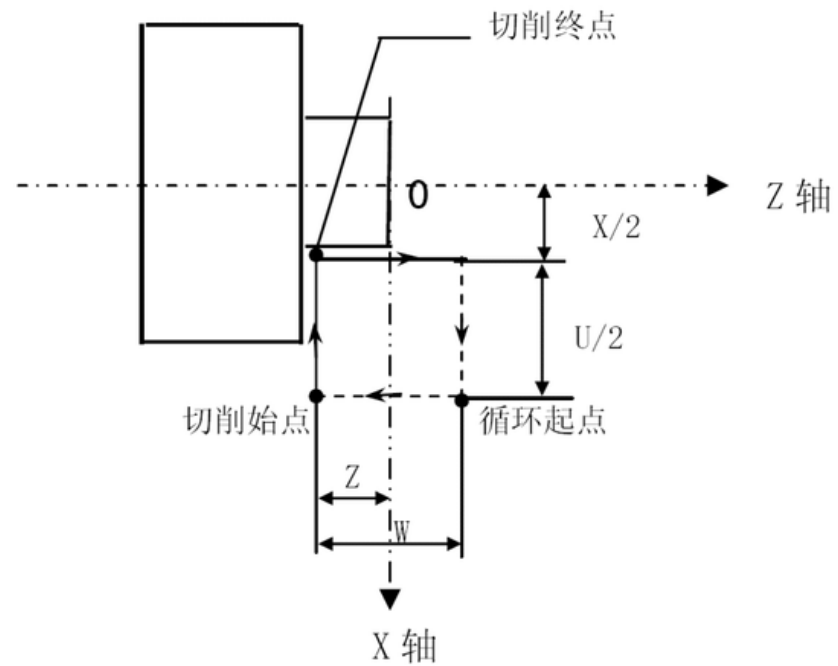

End face loop cutting

For example:

```

N10 M03 S1000;
N20 T0101;
N30 G00 X85 Z10 M08;
N40 G01 Z5 F200;
N50 G94 X30 Z-5 F100;
N60 Z-10;
N70 Z-15;
N80 G00 X100 Z60 M09;
N90 T0100 M05;
N100 M30;

```

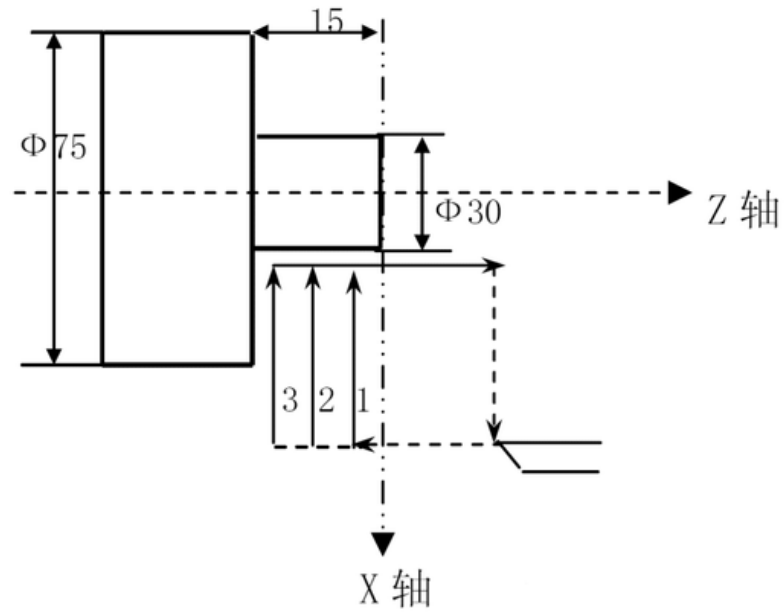

Taper end face loop format: G94 X(U) \_\_ Z (W) \_\_ R\_\_ F\_\_;

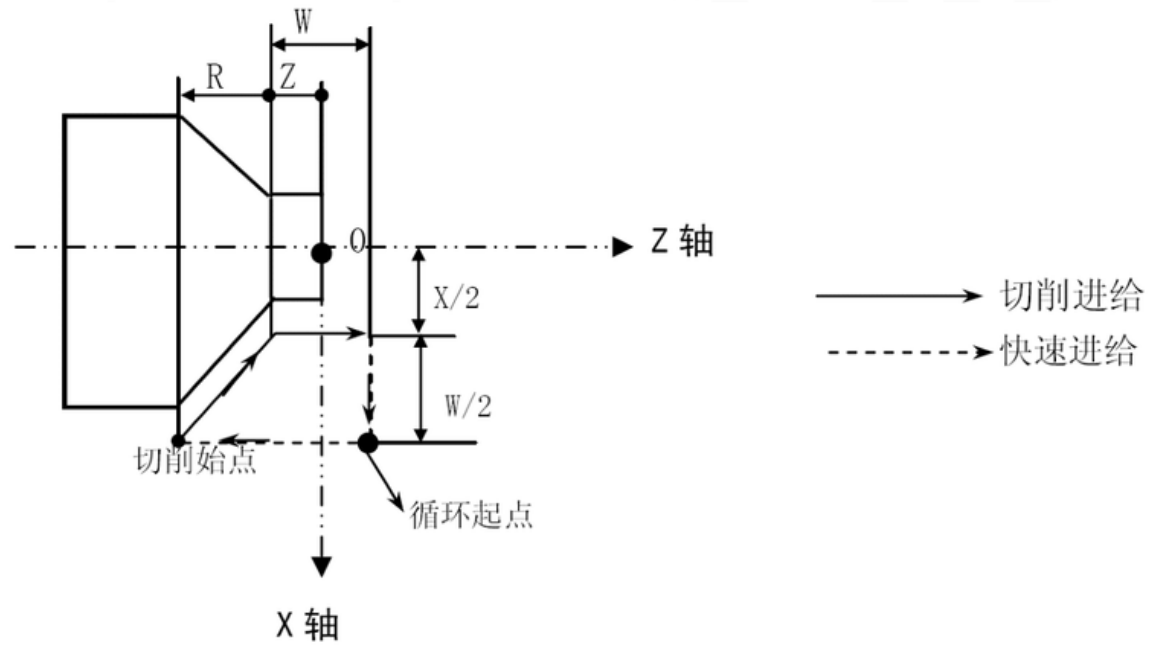

Taper end face loop cutting

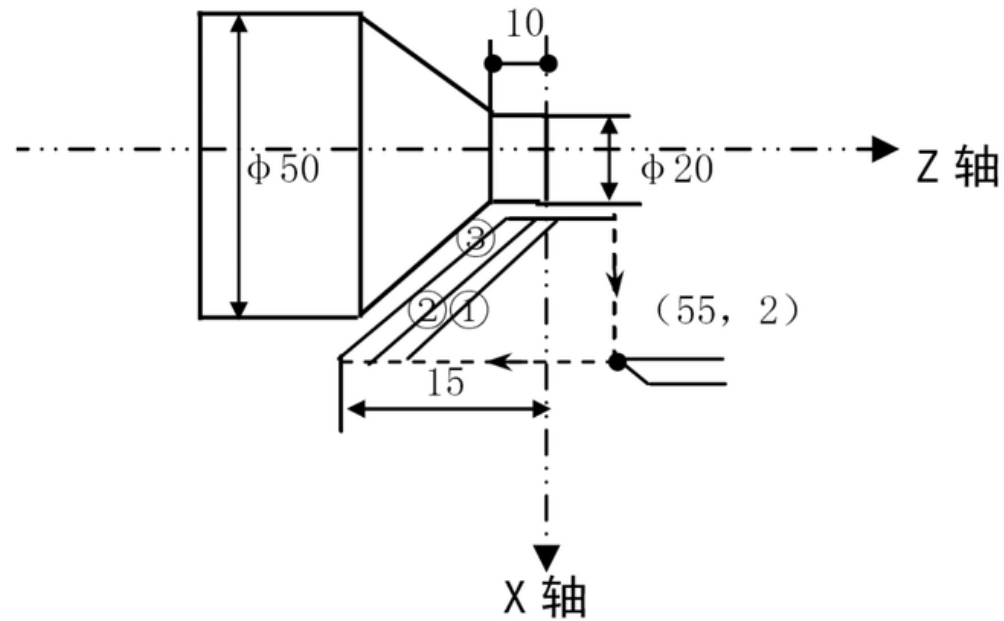

For example:

.....

```
N40 G01 X55 Z2 F200;
N50 G94 X20 Z0 R-5 F100;
N60 Z-5;
N70 Z-10;
N80 G00 X Z;
```

.....

### (11) Screw thread loop (G92)

Format:

指令格式: G92 X(U) \_ Z (W) \_ F(I) \_ R \_ L \_ J \_ K \_ P \_ ;

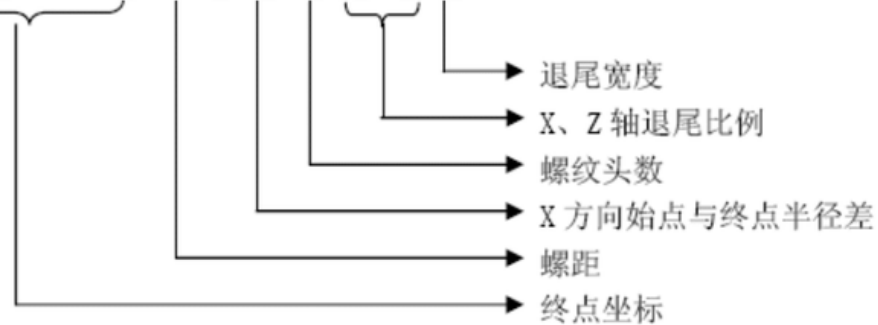

#### 1) Straight screw thread loop format:

G92 X(U) \_ Z (W) \_ F/I \_ ;

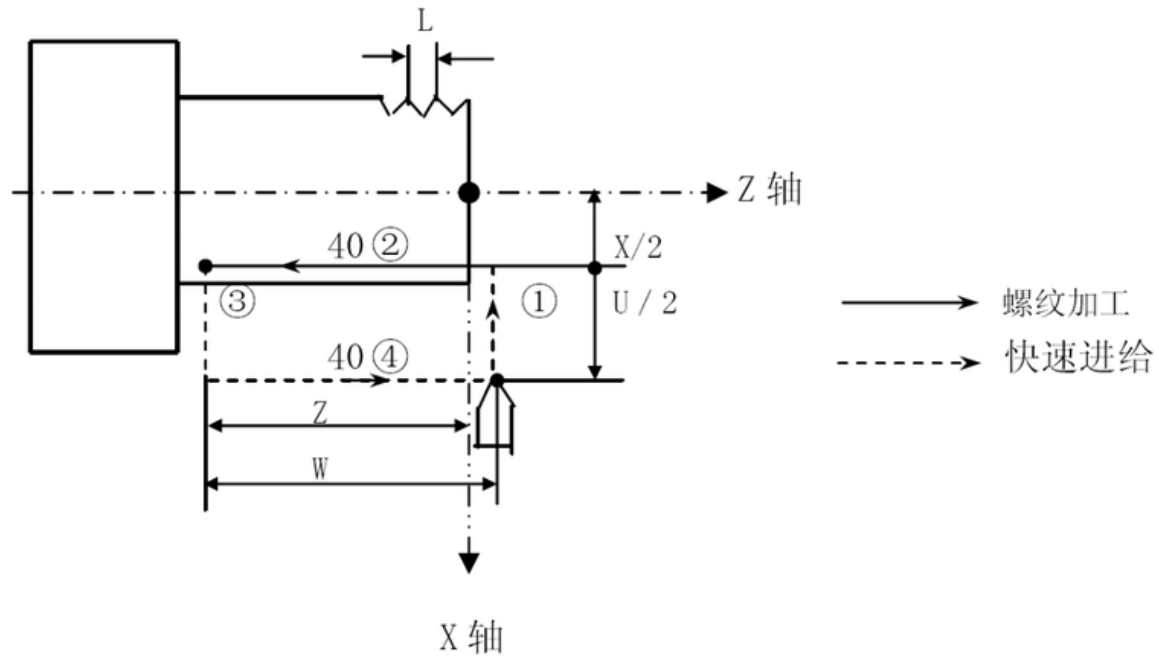

Straight screw thread loop

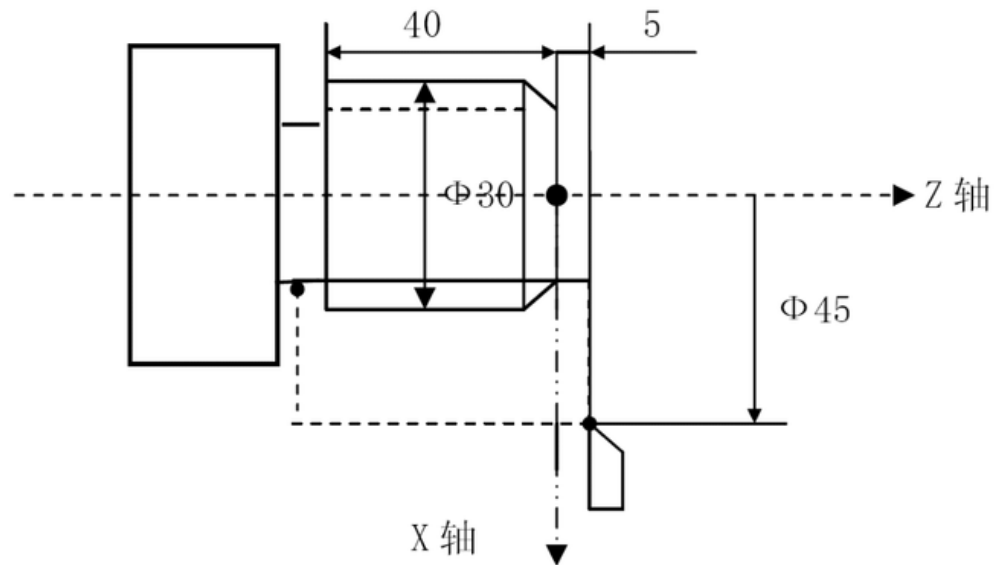

Format:

N10 M03 S××;

N20 T0101;

N30 G00 X45 Z5;

N40 G92 X29.2 Z-45 F1.5;

N50 X28.6;

N60 X28.2;

N70 X28.04;

N80 G00 X100 Z50;



N90 T0100 M05;

N100 M30;

2) Taper screw thread loop format:

G92 X(U) \_\_ Z (W) \_\_ R\_\_ F/I\_\_;

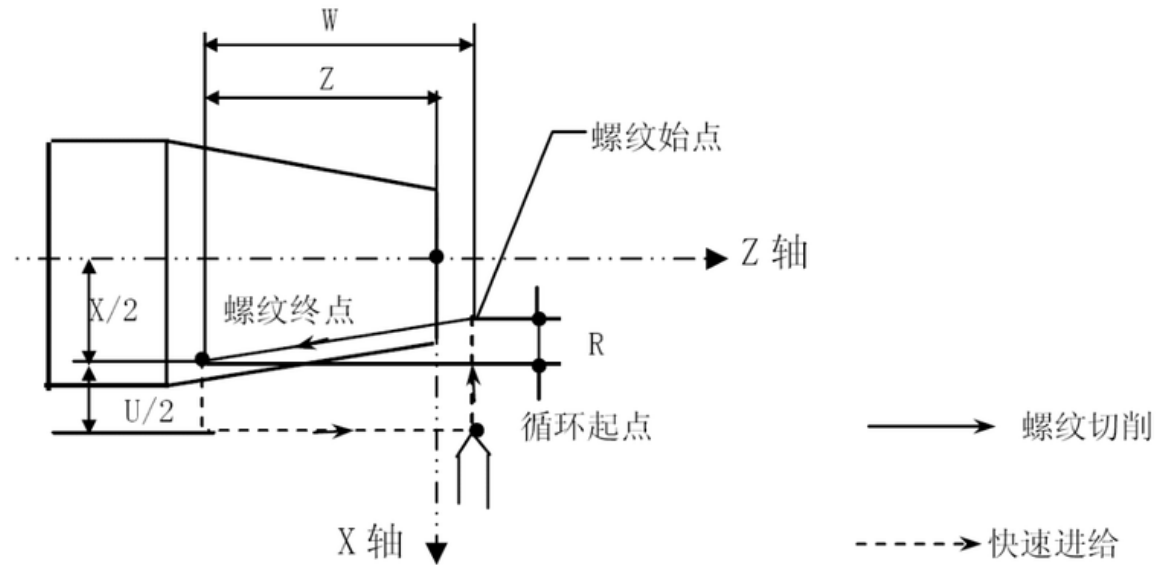

For example:

N10 M03 S××;

N20 T0101;

N30 G00 X55 Z10;

N40 G01 X60 Z5 F100;

N50 G90 X66.25 Z-60 R1.875;

N60 G92 X66.88 Z-50 R1.4 I11;

N70 X66.9 I11;

N80 X67 I11;

N90 X67.4 I11;

N100 X67.6 I11;

N110 X67.8 I11;

N120 G00 X100 Z50;

N130 T0100 M05;

N140 M30;

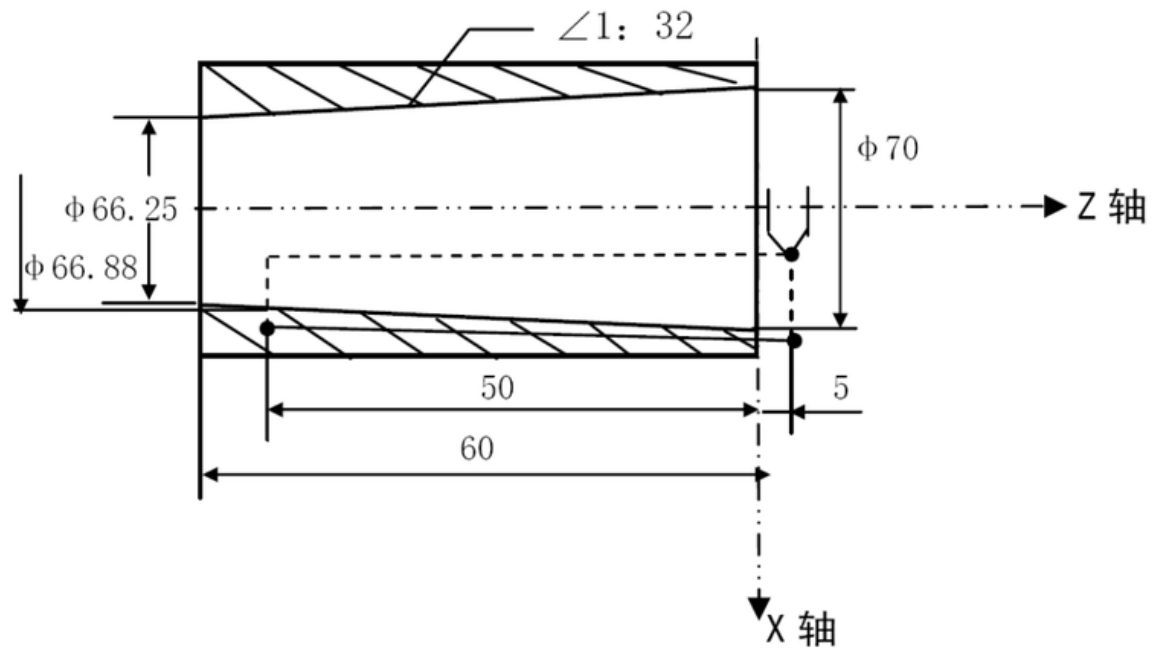

### (12) Tap loop (G93)

Format: G93 Z (W) F/I ;

For example:

M03 S500

G04 X1

G93 Z-100 F5

G00 X50

### (13) Column thick loop (G71)

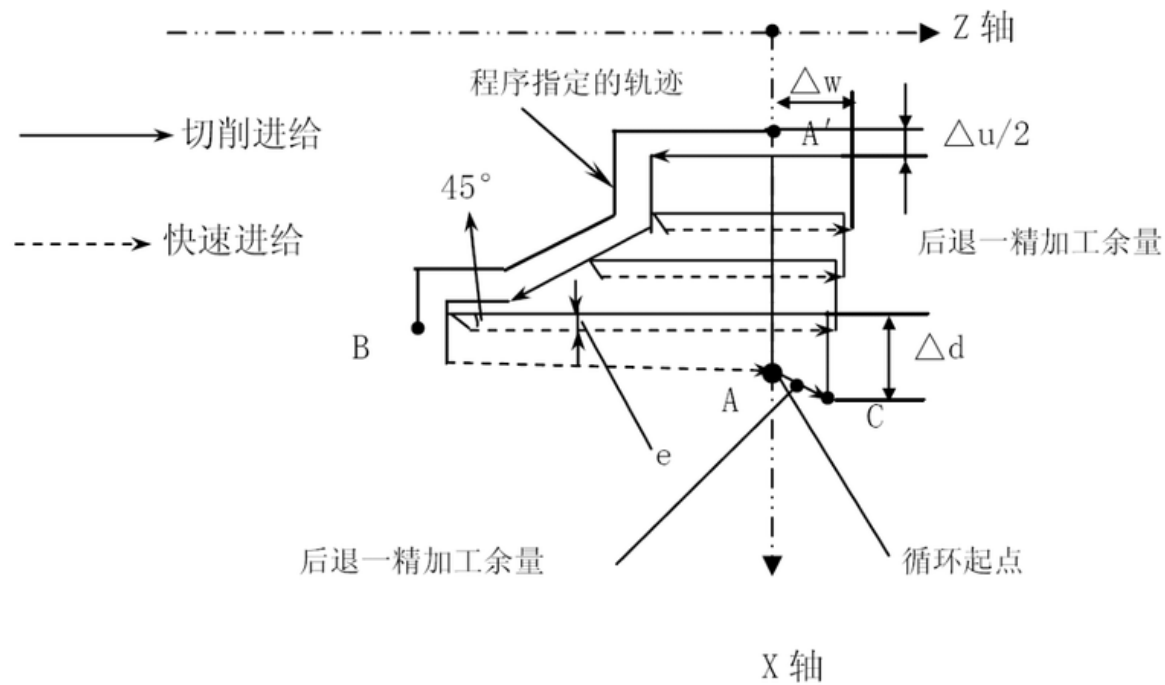

Column thick loop

Format:

G71 U ( $\Delta d$ ) R(e);

G71 P (ns) Q (nf) U ( $\Delta u$ ) W ( $\Delta w$ ) F (f) S (s) T (t);

$\Delta d$ : feed thickness, no signal; User parameter P1.

e: backward distance; User parameter P2.

ns: first N line.

nf: end N line.

$\Delta u$ : X remain; User parameter P4.

$\Delta w$ : Z remain; User parameter P5.

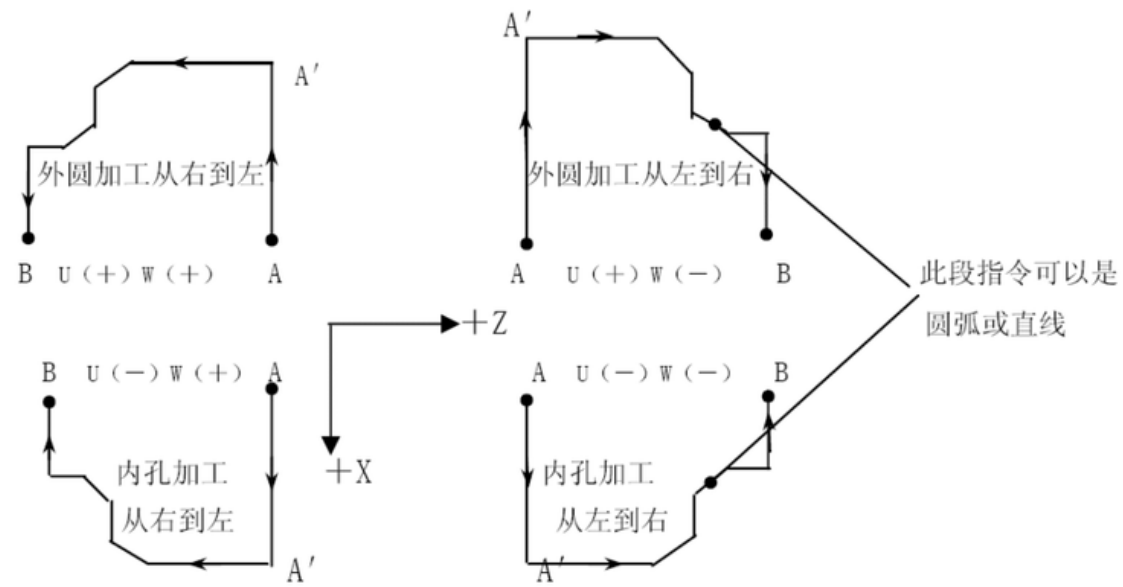

### (14) End face thick loop(G72)

Format:

G72 W ( $\Delta d$ ) R (e) ;

G72 P (ns) Q (nf) U ( $\Delta u$ ) W ( $\Delta w$ ) F (f) S (s) T (t) ;

$\Delta d$ 、e、ns、nf、 $\Delta u$ 、 $\Delta w$ 、f、s、t is same as G71.

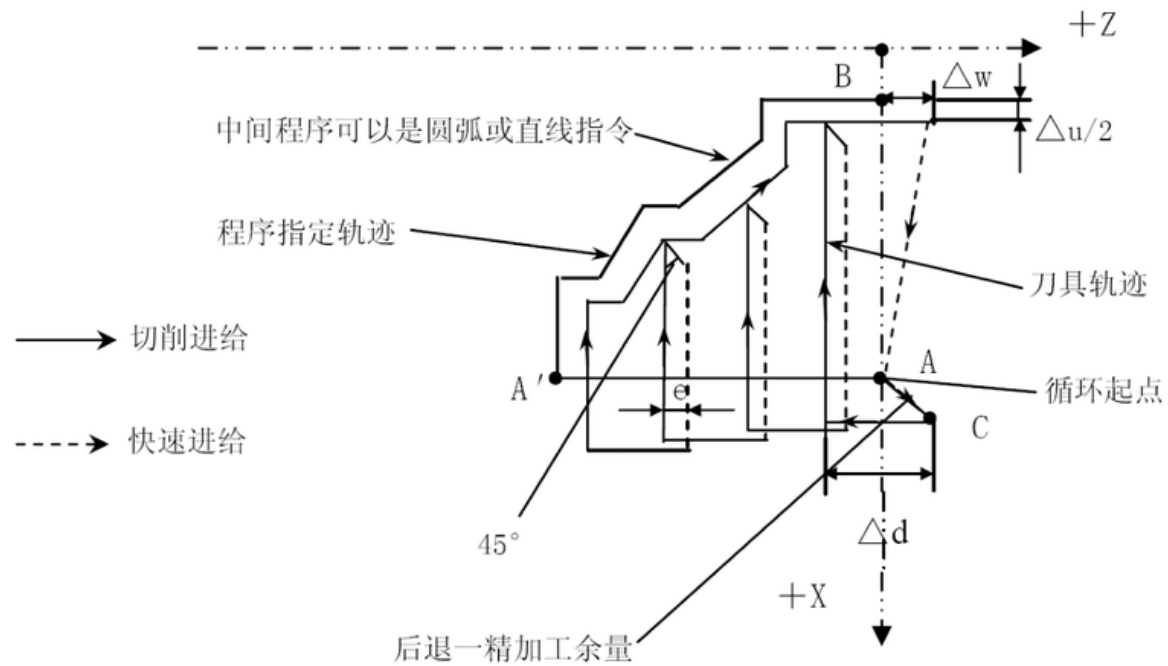

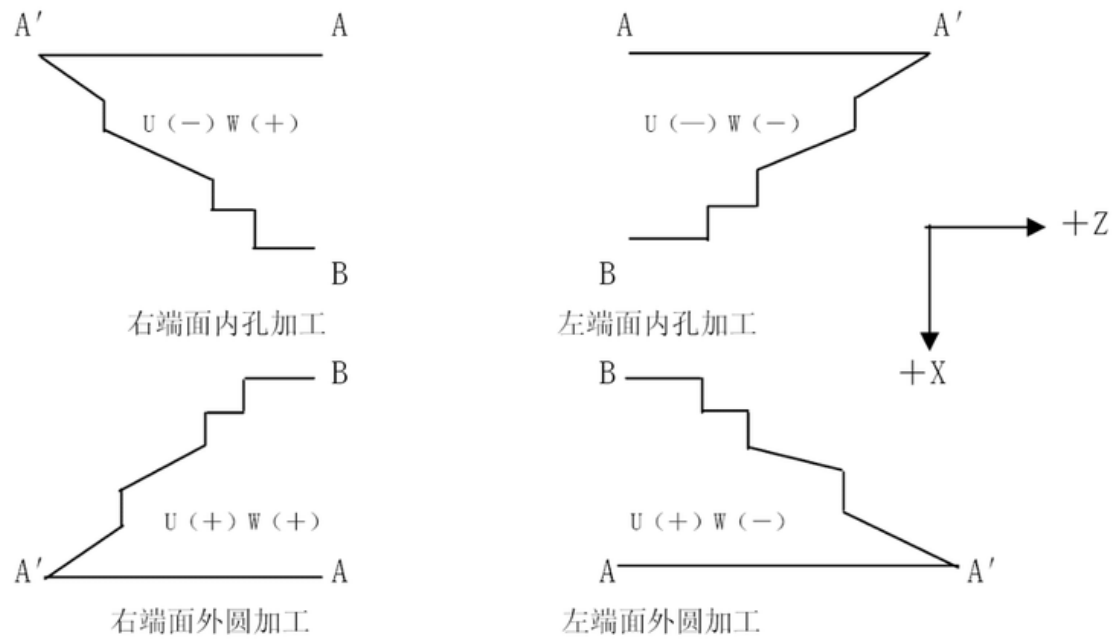

**(15) Close cutting loop(G73)**

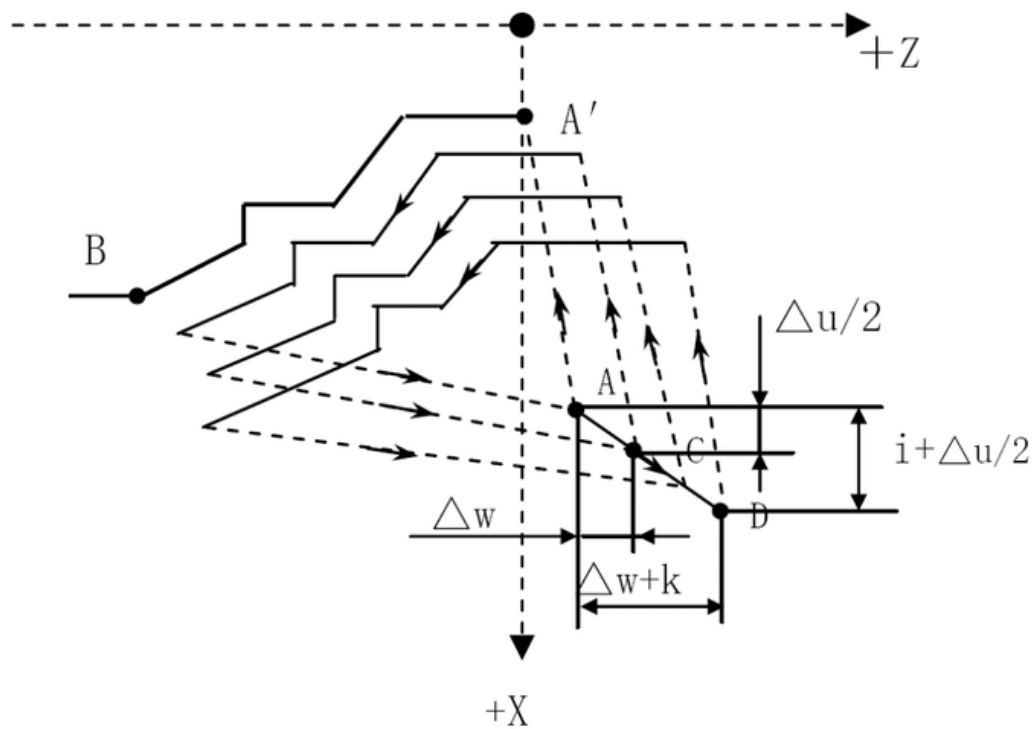

Format:

G73 U (i) \_\_ W (k) \_\_ R (d) \_\_;

G73 P (ns) \_\_ Q (nf) \_\_ U (Δu) \_\_ W (Δw) \_\_ F (f) \_\_ S (s) \_\_ T (t)

\_\_;

```

N (ns) .....; --\
          .....; |
          .       > A→A' →B ,ns to nf
          .       |
          .       |
          .       |
N (nf) .....; --/

```

i: X rough thickness; User parameter P7.

k: Z rough thickness; User parameter P8.

d: cutting times; User parameter P6.

Others is same as G71.

### (16) Finish machining loop (G70)

Format:

G70 P (ns) Q (nf)

For example1: G71 G70

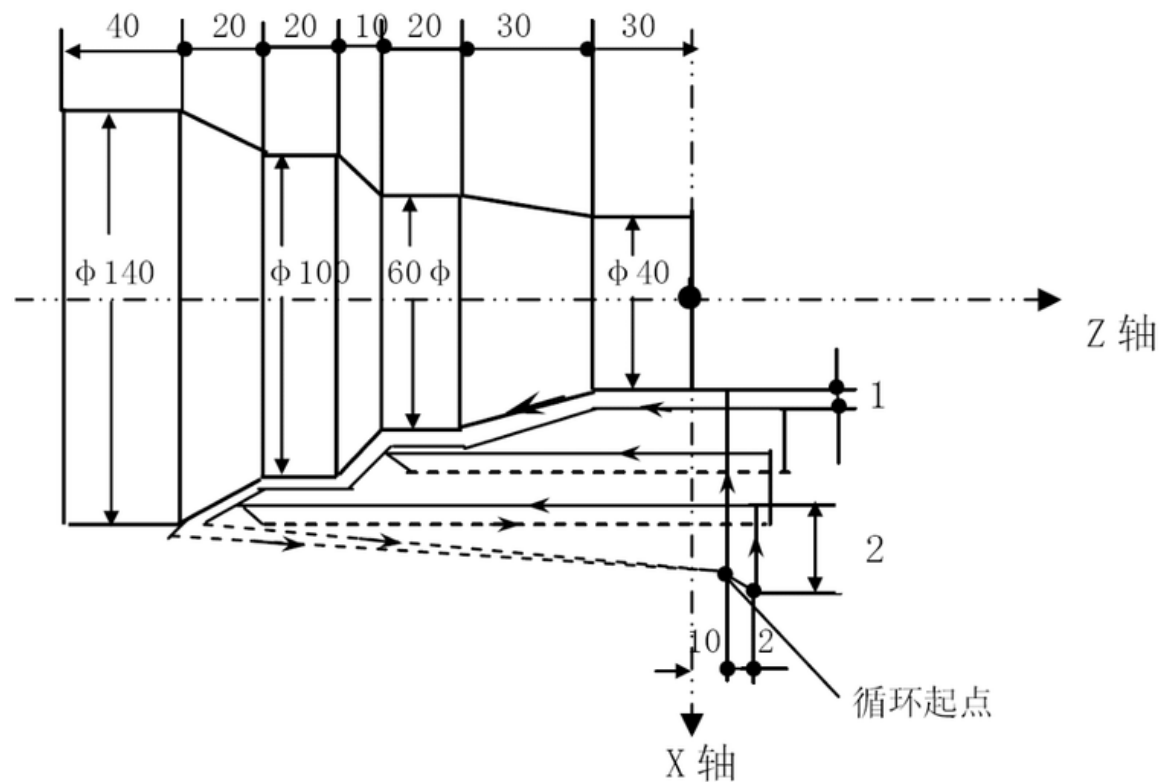

N10 M03 S1500;

N20 T0101;

```

N30 G00 X160 Z10;
N40 G71 U2 R1;
N50 G71 P60 Q120 U2 W1 F100 S2000
N60 G00 X40;
N70 G01 Z-30 F80;
N80 X60 W-30;
N90 W-20;
N100 X100 W-10;
N110 W-20;
N120 X140 W-20;
N130 G70 P60 Q120;
N140 G00 X200 Z50;
N150 T0100 M05;
N160 M30;

```

For example2: G72 G70

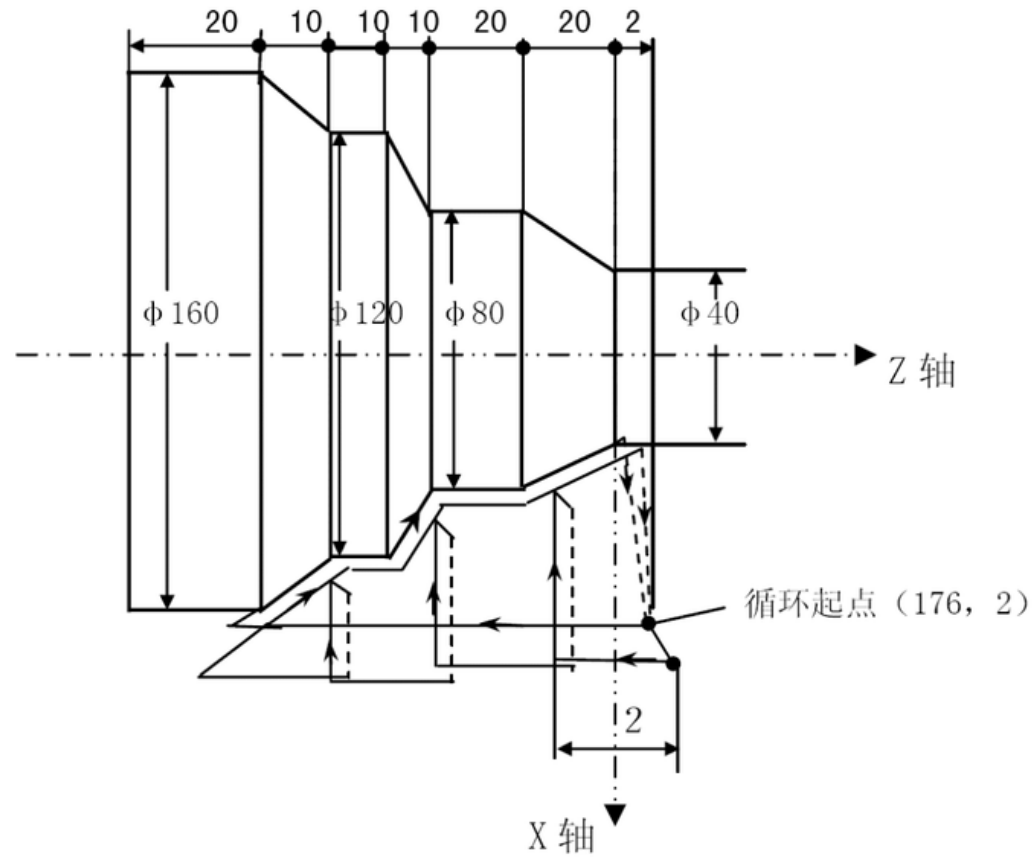

```

N10 M03 S2000;
N20 T0202;
N30 G00 X176 Z2;
N40 G72 W2 R1;

```

```

N50 G72 P60 Q120 U2 W1 F100 ;
N60 G00 Z-72;
N70 G01 X160 Z-70 F80;
N80 X120 W10;
N90 W10;
N100 X80 W10;
N110 W20;
N120 X36 W22.08;
N130 G70 P60 Q120;
N140 G00 X200 Z50;
N150 T0200 M05;
N160 M30;
For example3: G73 G70

```

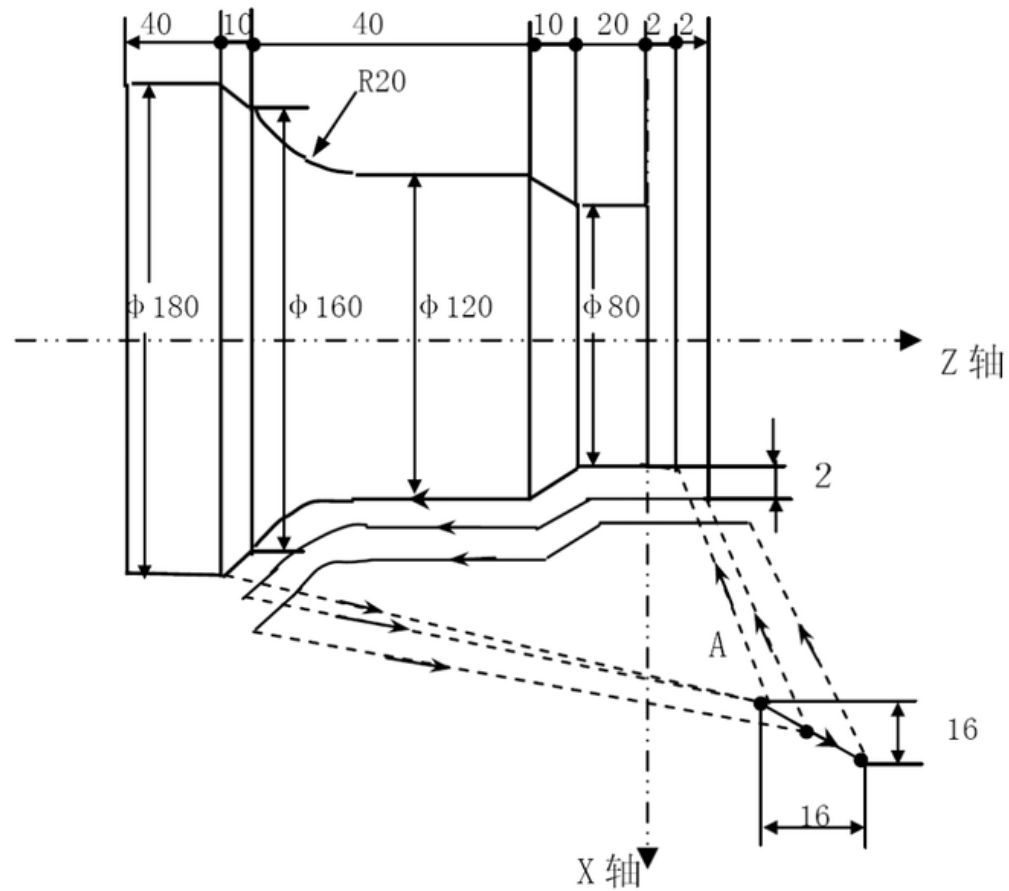

```

N10 M03 S3000;
N20 T0303;
N30 G00 X220 Z40;
N40 G73 U14 W14 R0.010;
N50 G73 P60 Q110 U4 W2 F100;

```



```

N60 G00 X80 Z2;
N70 G01 Z-20 F80;
N80 X120 W-10;
N90 W-20;
N100 G02 X160 W-20 R20;
N110 G01 X180 W-10;
N120 G70 P60 Q110;
N130 G00 X250 Z50;
N140 T0300 M05;
N150 M30;

```

### (17) End face deep hole loop(G74)

Format:

G74 R (e) ;

G74 X (u) P ( $\Delta i$ ) Z (w) Q ( $\Delta k$ ) F (f) ;

e: backward distance;User parameter P10.

Z (w) Z depth;

X (u) X end-point coordinate;

$\Delta k$ : Z feed thickness;User parameter P9.

$\Delta i$ : X feed thickness.

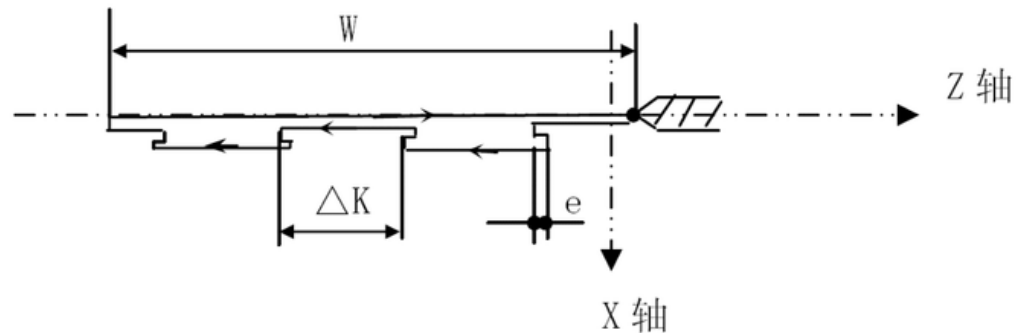

For example:

```

N10 G00 X0 Z10;
N20 G74 R2;
N30 G74 Z-80 Q10000 F800;
N40 G00 X50 Z50;
N50 M30;

```

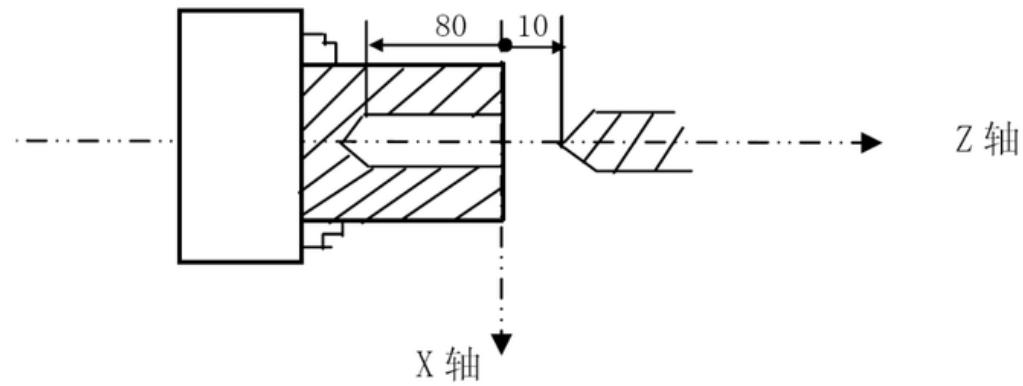

### (18) Slot cutting loop(G75)

Format:

G75 R(e)\_\_\_;

G75 X(U)\_\_\_ P( $\Delta i$ )\_\_\_ Z (w) \_\_\_ Q ( $\Delta k$ ) \_\_\_ F(f)\_\_\_;

e: backward distance; User parameter P10.

X (u) X depth;

Z (w) Z end-point coordinate;

$\Delta i$ : X feed thickness; User parameter P9.

$\Delta k$ : Z feed thickness.

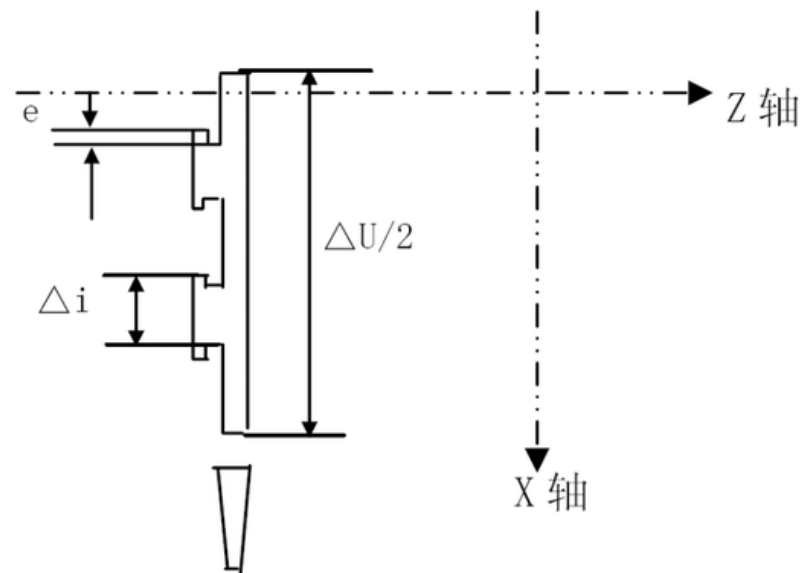

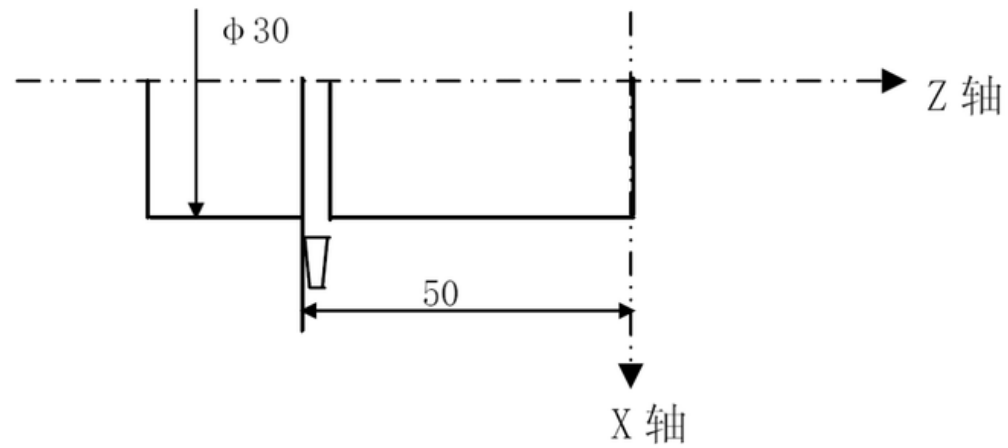

For example:

```
N10 M03 S1000;  
N20 T0101;  
N30 G00 X35 Z-50;  
N40 G75 R1;  
N50 G75 X-1 P5000 F60;  
N60 G00 X100 Z50 M09;  
N70 M05;  
N80 T0100;  
N90 M30;
```

### (19) Complex screw thread loop(G76)

As fig:

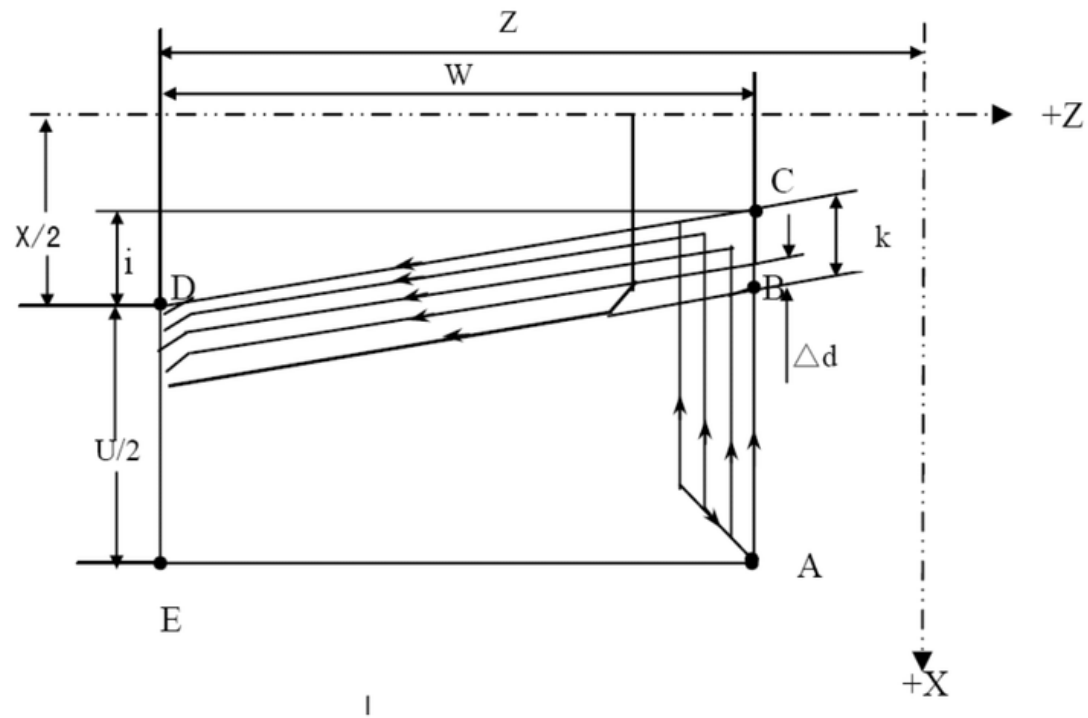

Cutting method:

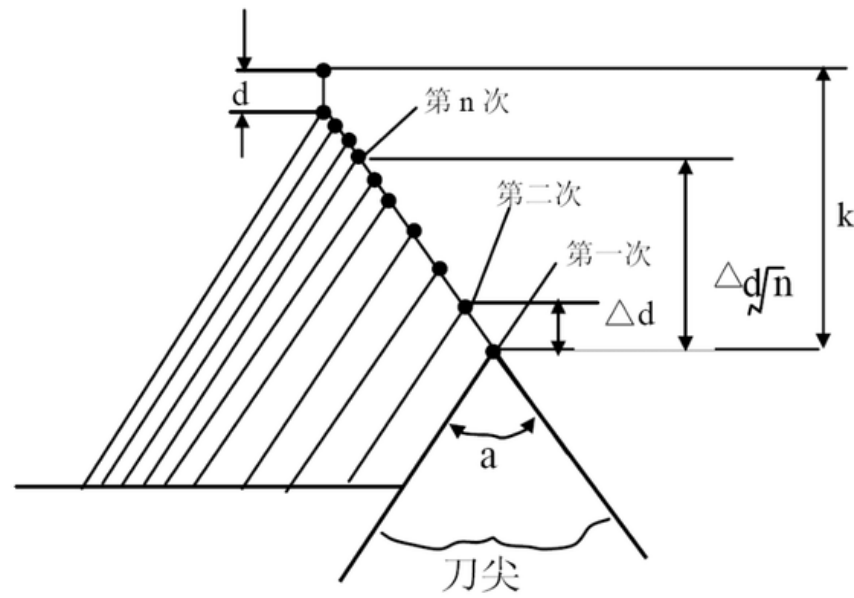

Format:

G76 P(b) (c) (m) (r) (a) Q( $\Delta d_{min}$ ) R(d) ;

G76 X(U) Z(W) R(i) P(k) Q( $\Delta d$ ) F(f) L(L) [or SP];

- b: 0——degression feed;
- 1——equidistance feed;
- c: 0——right enter;
- 1——left enter;

m: finish turn times, User parameter P11.  
 r: quit length, User parameter P12.  
 a: thread tooth angle (degree), User parameter P13.  
 $\Delta$ min: minimal cutting depth, User parameter P14.  
 d: finish turn remaining, User parameter P15.  
 I: X taper screw thread feed measure.  
 f: metric lead.  
 L: multiple thread head numbers.  
 SP: start angle: 0-360°

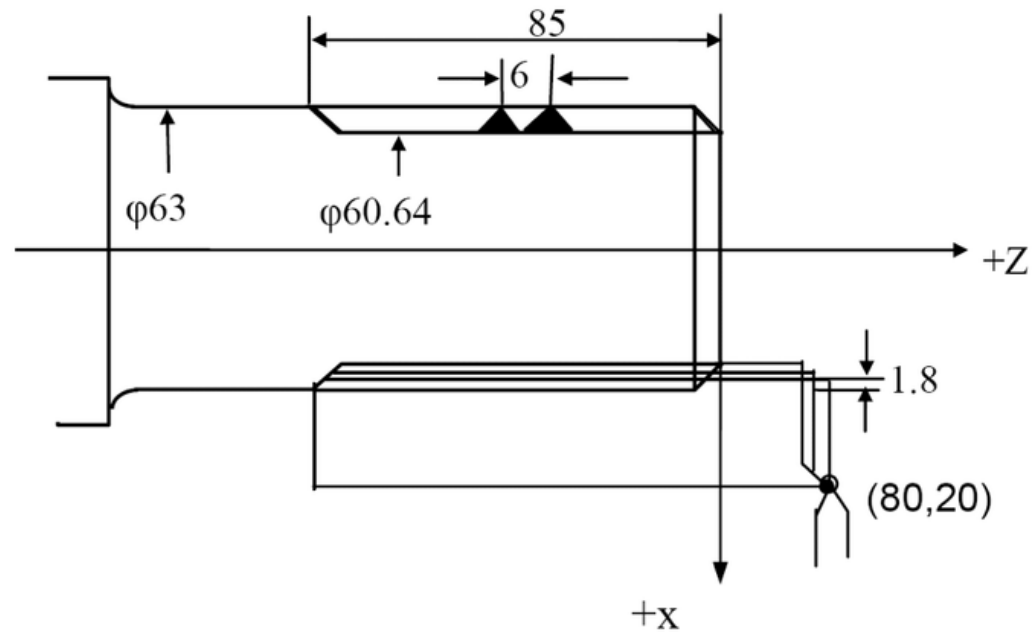

```

N10 M03 S1000;
N20 T0101;
N30 G00 X80 Z20;
N40 G76 P00011060 Q100 R0.1 ;
N50 G76 X60.64 Z-85 P3680 Q1800 F6.0 ;
N60 G00 X100 Z50;
N70 T0100;
N80 M05;
N90 M30;
    
```

### (20) Fix loop(G22、G800)

Format: G22 L-

.  
 .  
 .

```

G800 ;End
For example:
N0000 M03 M08
N0001 G0 X200 Z200
N0002 G01 W-100 F300
N0003 G22 L6 ; loop 6 times
N0004 G01 U-22 F100
N0005 W-11 U6
N0006 W-30
N0007 W-10 U5
N0008 G0 U10
N0009 W51
N0010 G800 ; loop end
N0011 G26
N0012 M30

```

### (21) Part coordinate setup(G52), Setup tool coor (G184、G185)

Format:

G52 X\_Z\_ ; absolute coordinate setup

G52 U\_W\_ ;relative coordinate setup

G52 X0Z0 ; cancel

G184 X\_Z\_P\_L\_ ;setup current&P&L tool absolute coordinate

G184 U\_W\_P\_L\_ ;setup current&P&L tool relative coordinate

G185 X\_Z\_ ; setup all tool absolute coordinte

G185 U\_W\_ ; setup all tool relative coordinte

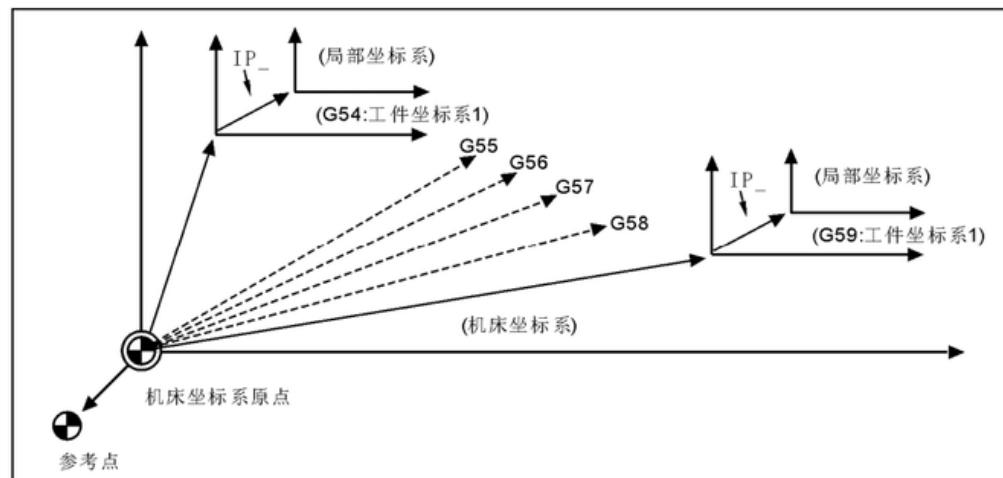

Part coordinate setup

For example:

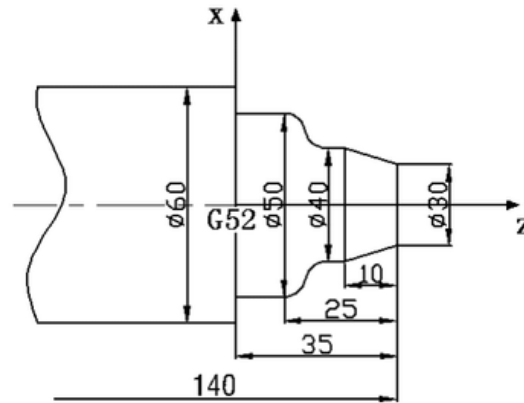

```

N1 G00 X60 Z20
N2 G52 X0 Z-236
N3 T0101
N4 M03 S800 M08
N5 G01 Z35 F100
N6 X-1
N7 X70
N8 G71 U2 R1
N8 G71 P10 Q15 U0.5 W0.5 F150
N10 G01 X30
N11 X40 Z25
N12 Z20
N13 G02 X50 Z15 R5
N14 G03 X60 Z10 R5
N15 G01 Z0
N16 G00 X70
N17 G52 X0 Z0
N18 M05
N19 M30

```

## (22) Back start point(G26、G261、G262、G263、G264)

Format:

G26、G261、G262、G263、G264; XZ、X、Y、Z、A

Format:

```

N0000 G00 X120 Z300 ;
N0001 G01 X150 Z50 F160 ;
N0002 G26 ;
N0003 M2 ;

```

**(23) Back to G25 point(G25、G61、G611、G612、G613、G614)**

Format:

G25 ;Save current coordinate

G61、G611、G612、G613、G614; XZ, X, Y, Z, A

For example:

```

N0000 G0 X20 Z80 ;
N0001 G01 U5 W-16 F200 ;
N0002 W-100 ;
N0003 G00 U10 ;
N0004 Z80 ;
N0005 G25
N0006 G01 U10 W-30 ;
N0007 G0 X100 Z200 ;
N0008 G61 ;
N0009 M2 ;

```

**(24) continue feed cutting(G60/G64)**

Format: G60 ; cancel

G64 ; continue feed

**(25) Constant speed cutting(G96/G97)**

Format: G96 S\_ Constant speed cutting

G97 cancel

For example:

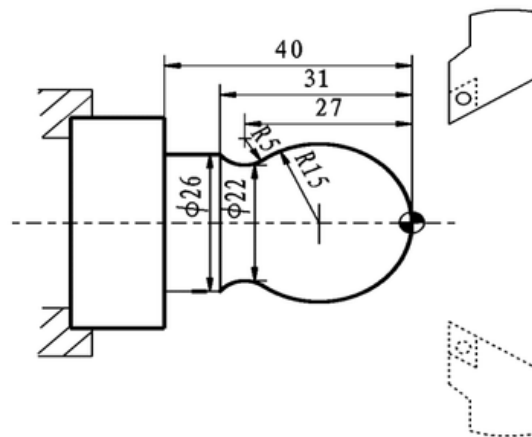

N1 T0102 X40 Z5

N2 M03 S400

N3 G96 S80



```

N4 G00 X0
N5 G01 Z0 F60
N6 G03 U24 W-24 R15
N7 G02 X26 Z-31 R5
N8 G01 Z-40
N9 X40 Z5
N10 G97 S300
N11 M30

```

## (26) Feed mode(G98、G99)

Format:

G98 feed per minute instruction

G99 feed per revolution instruction

## (27) Check skip(G31、G311)

Format: G31 X\_ Z\_ F\_ P\_ ;No alarm

G311 X\_ Z\_ F\_ P\_ ;alarm

P:Nline+(X00/X39+1000 or 2000), 1000 means availability skip, 2000 mean invalidation skip.

For example: G31 X50 Z100 F100 P331022 ;if X22 availability then go to N33.

G311 X50 Z100 F100 P2021 ;if X21 invalidation then go to next line.

## (28) Work coordinate(G53/G54/G55/G56/G57/G58/G59)

Format: G53(G54/G55/G56/G57/G58/G59)

G53 machine coordinate

G54 workpiece coordinate 1

G55 workpiece coordinate 2

G56 workpiece coordinate 3

G57 workpiece coordinate 4

G58 workpiece coordinate 5

G59 workpiece coordinate 6

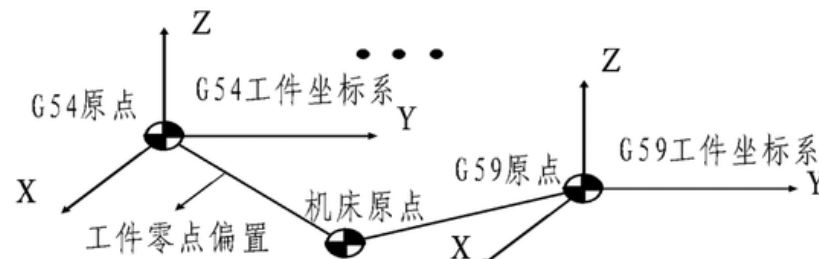

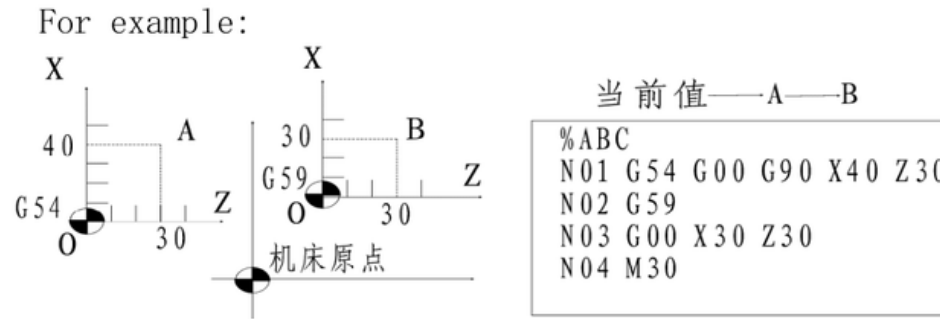

## (29) Tool radius compensate G40、G41、G42

Format :G40 ; tool radius compensation cancellation

G41 ; tool radius compensation of cutter in the left of workpiece offset.

G42 ; tool radius compensation of cutter in the right of workpiece offset.

The left and right in G41, G42 are viewed from direction of cutting, tool lies in the left or right of workpiece. Tool radius is designated by R. executing offset begins at the program line of G41, G42. in the closed angle, system generates automatically transiting arc, allowing tool radius offset vector of last program segment transmit to that of the next program segment. Tool offset vector describes value and direction method of tool offset, its radius vector is tool radius. For arc, its direction is in radius direction. For line, its direction is vertical to the line direction.

When it transits at the closed angle arc, it will cause errors when the angle is less than 180 degree, because the transition becomes the inner closed angle transition. This system only transits outer closed angle, and remains valid only for G01, G02, G03, that is, the outer closed angle between strait line and strait line, arc and arc, strait line and arc can generate transiting arc.

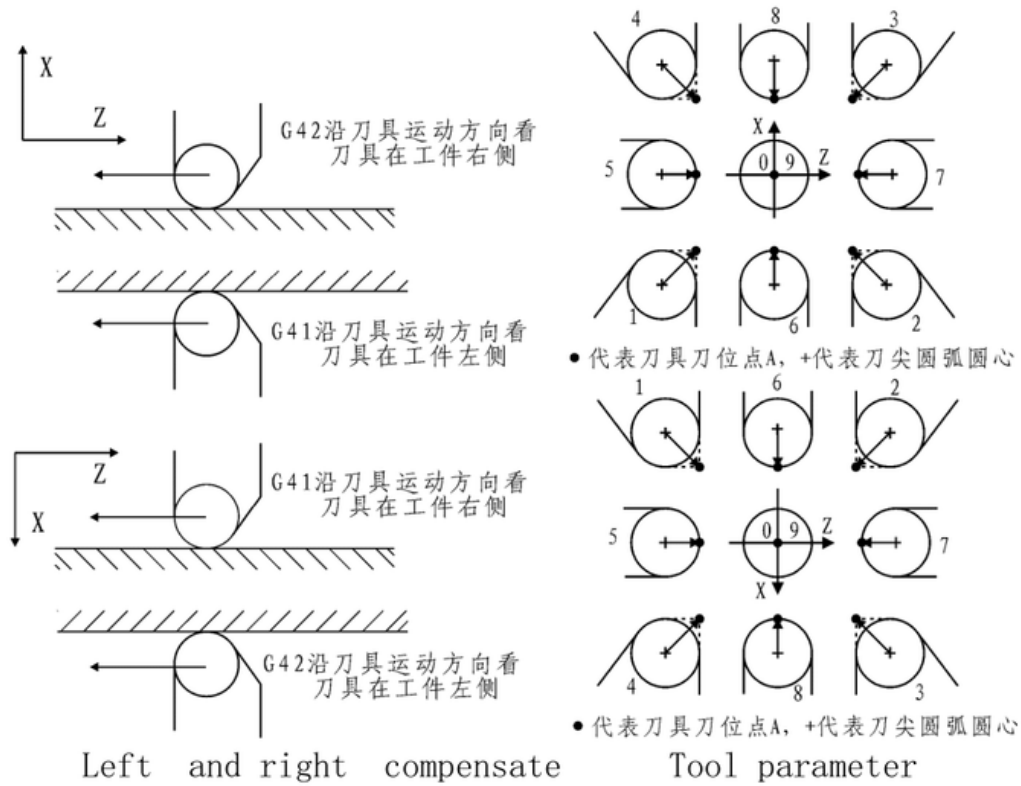

For example:

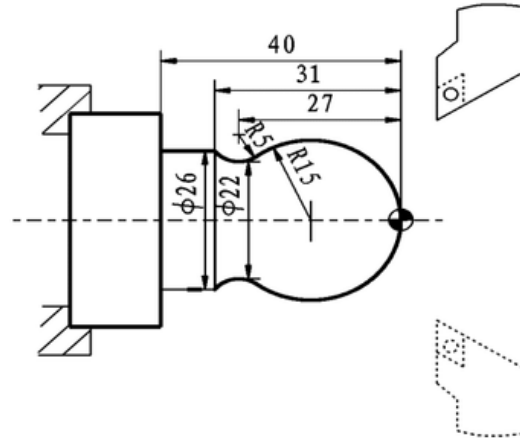

```

N1 T0101
N2 M03 S400
N3 G00 X40 Z5
N4 G00 X0 G42
N5 G01 Z0 F60
N6 G03 U24 W-24 R15
N7 G02 X26 Z-31 R5
N8 G01 Z-40
N9 G00 X30
N10 G40 X40 Z5
    
```

N11 M30

**(30) Pole coordinate program(G15/G16)**

Format:

```
G15      ; cancel
G16 IP-(XZ) ; pole coordinate
```

For example:

```
N1 G16 X0 Z0 ;
N2 G01 X30.0 Z100.0 F200.0
N3 X150.0 ;
N4 X270.0 ;
N5 G15 ;
N6 M02
```

**(31) Switch millimeter and inch(G20/G21)**

Format:

```
G20 ; inch;
G21 ; millimeter;
```

**(32) Call sub-program (M97/M98/M99)**

M97 P Non-condition to jump to P word

M98 P L Call sub-program. P word point out the name of sub-program.

for example: Psub\\%ab12 means the name of sub-program is  
CNC\\sub\\%ab12, L word point out call times.

M99 Back of sub-program

The Sub-program can embedded call as follow :

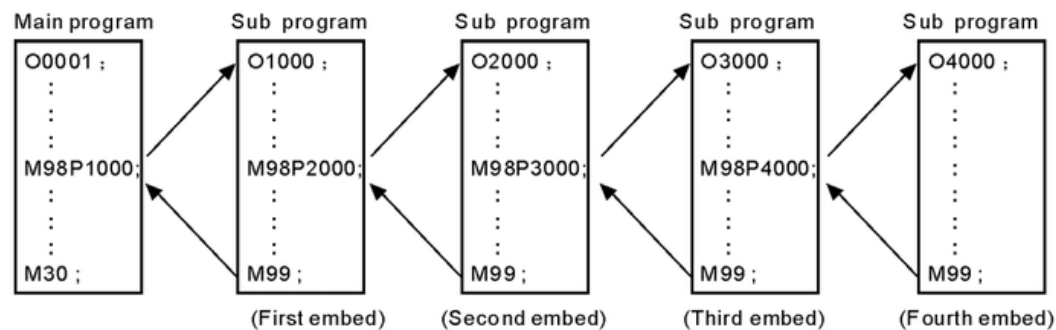

For example

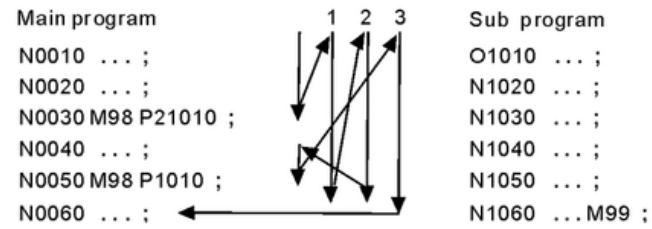

### (33) T tool

Format            fuction  
 Tab                a: Tool numbera, b: compensate number

Format:

```
N0000 T0101
N0001 G0 X30 Z500
N0002 T0303
N0003 G00 X50
N0004 T0505
N0005 M02
```

### (34) S、SS SP speed

The first SP use “S” ,speed parameter P36 control the highest speed,output 0-10V frequency conversion voltage.

The second SP use “SS” ,speed parameter P40 control the highest speed,output 0-10V frequency conversion voltage.

### (35) F feed speed

F use for G01、G02、G03 etc. feed speed.

G98: F0.01-20000mm/min, G99: 0.001-500mm/r.

## **Chapter 5 System installation and connection**

### **5.1 system installation and connection**

At first, users should check whether the hardware is complete, unwounded and compatible, such as: cnc system, driving power, servo motor, photoelectric encoder, electric tool carrier.

The installation of cnc system must be fastened tightly, with some spaces around to ensure the ventilation of air. Panel should be put in a place where it is not only convenient to operate and but also able to avoid hurt of heating by scrap iron.

Intense current, weak current must be put separately, cnc system and driver should be possibly away from the machine intense current. In order to reduce interference, all signal cables should be kept away from AC contactor. Photoelectric encoder, limit, basic point signal are advisably not to be connected directly to cnc system through intense current box. All power cords must be earthing.

Fix all plugs with screw. Forbid to insert and extract all cables when power is on.

In installation of cnc system, panel should avoid hurting by hard and sharp materials. If the painting of other part of machine is needed, please take off cnc system to keep it clean.

To ensure there is no strong magnet and current interference, keep away from inflammable, explosive and other danger materials.

### **5.2 system installation dimension**

This system has two types of installation, except that the installation dimension are different, the other functions are same.

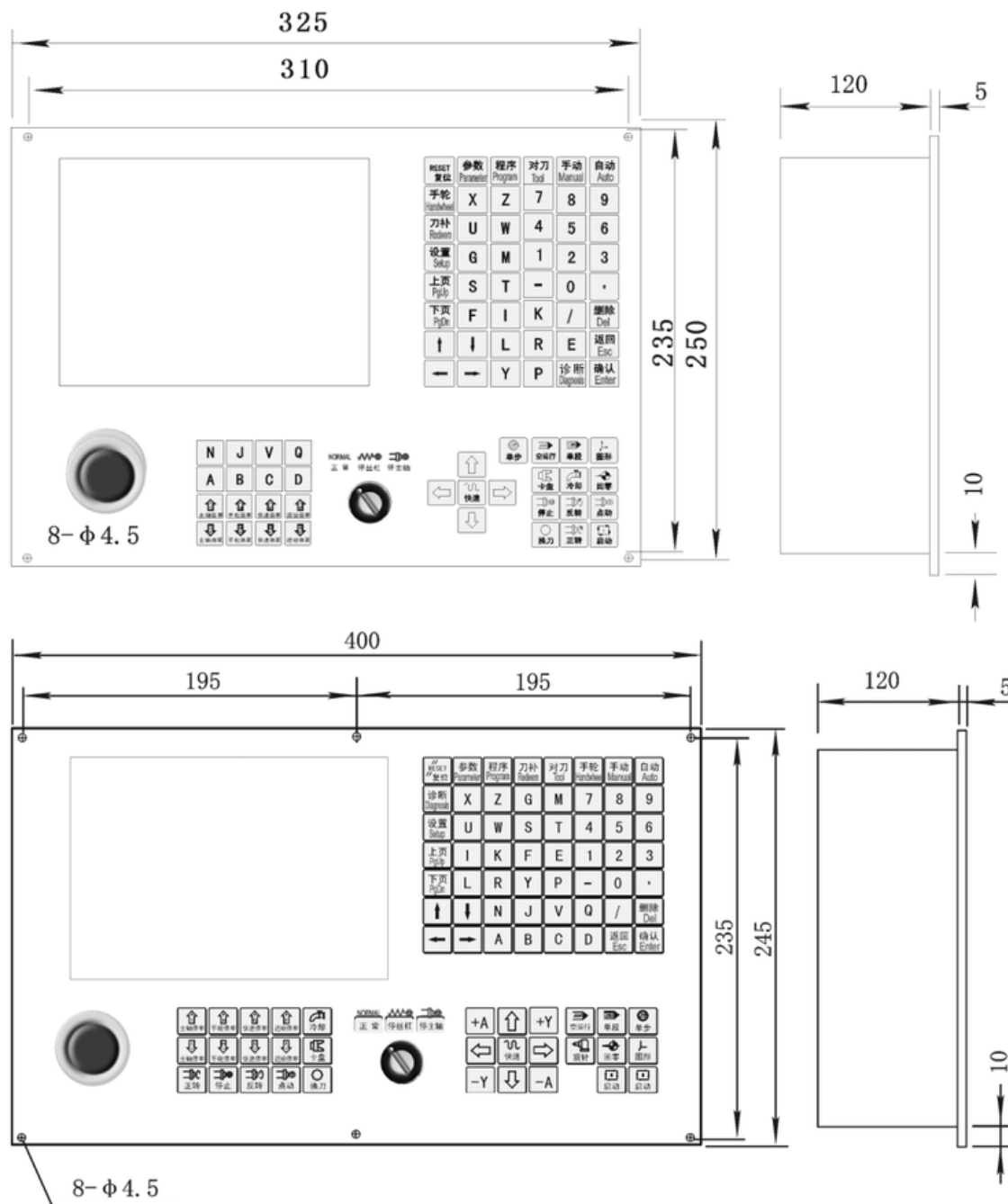

### 5.3 system rear view

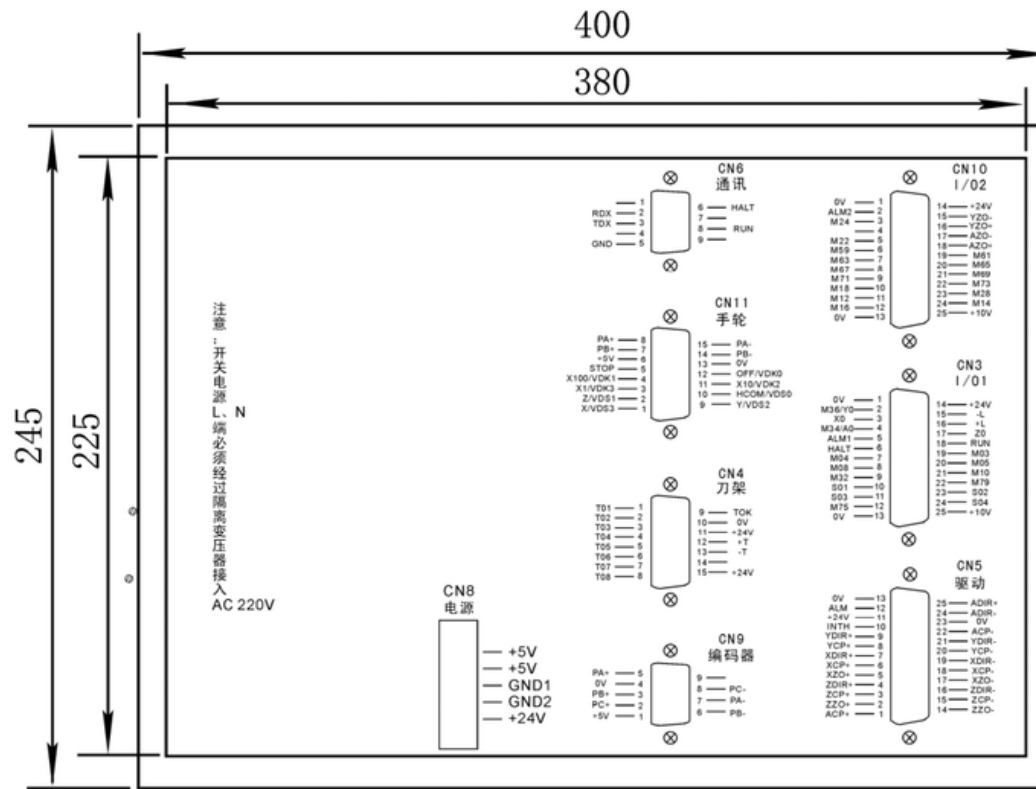

## 5.4 interface connection graph

### 5.4.1 CN4 and electric tool carrier connection

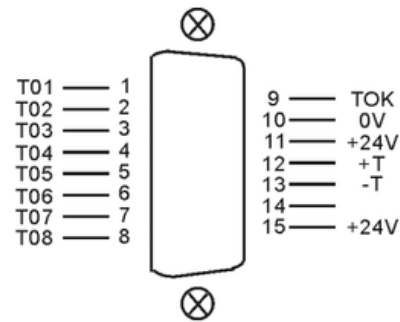

CN4 DB15(hole) electric tool carrier				
signal	pin	I/O	function	availability
0V	10	OUT	0V	0V
+24V	11、15	OUT	+24V	+24V
+T	12	OUT	Positive rotate	0V
-T	13	OUT	Reverse rotate	0V



T1	1	IN	T1 signal	0V
T2	2	IN	T2 signal	0V
T3	3	IN	T3 signal	0V
T4	4	IN	T4 signal	0V
T5	5	IN	T5 signal	0V
T6	6	IN	T6 signal	0V
T7	7	IN	T7 signal	0V
T8	8	IN	T8 signal	0V
TOK	9	IN	Lock signal	0V

System can control 1-99 Tools. Active tools is 8 Tools, default is 4. Totality Tools setup in “Redeem” press “C”. Interfix Tool parameter as:

- 1, Active tool function  
[1 mean Yes, 0 mean No]
- 2, Active tool number
- 4, Tool positive rotate max-time(s)
- 5, Delay time after tool positive rotate(ms)
- 6, Delay time after tool stop(ms)
- 7, Tighten time of tool reverse rotate(ms)
- 9, Have total signal TOK(1 mean have)
- 10, C Tool radius compensation's establish(0 mean A, 1 mean B)
- 11, C Tool radius compensation's cancel(0 mean A, 1 mean B)
- 20, Active tool mode  
[1 mean normal, 0 mean coding tool]

System output signal +T、-T:

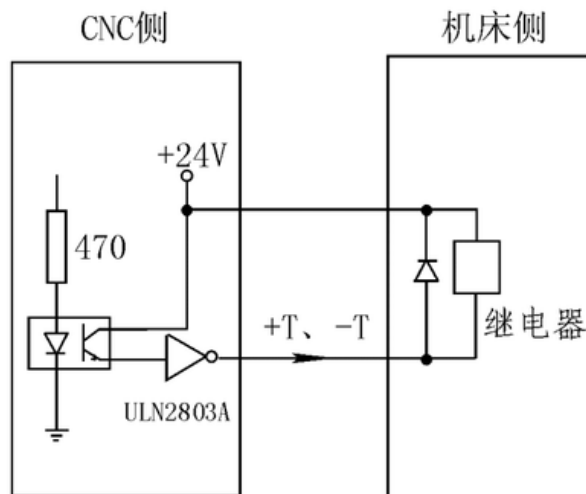

Tool input T1~T8、TOK signal:

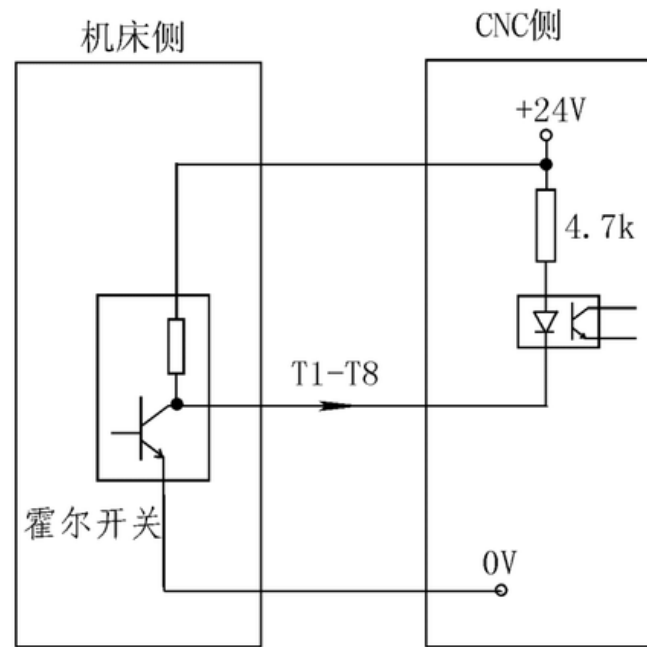

### 5.4.2 CN9 and spindle encoder connection

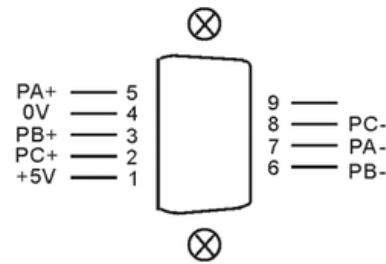

CN9 DB9(pin) spindle encoder				
signal	pin	I/O	function	availability
0V	4	OUT	0V	0V
+5V	1	OUT	+5V	+5V
PA+	5	IN	+A signal	5V
PA-	7	IN	-A signal	
PB+	3	IN	+B signal	5V
PB-	6	IN	-B signal	
PC+	2	IN	+Z signal	5V
PC-	8	IN	-Z signal	

Encode input signal PA、PB、PC:

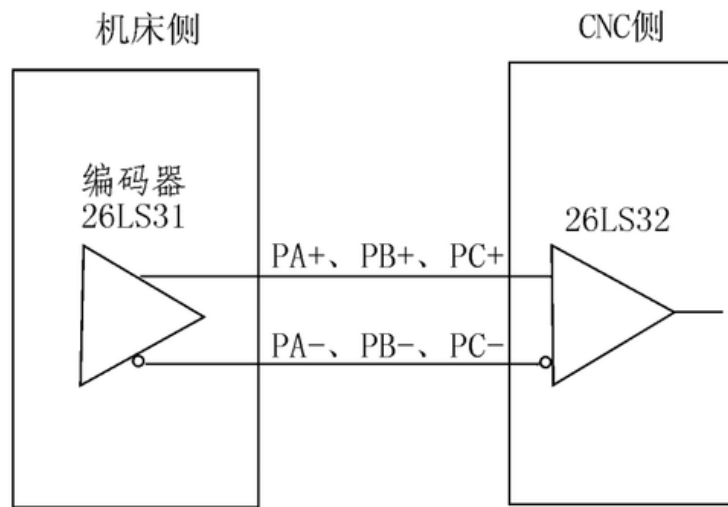

### 5.4.3 CN6 and computer system connection

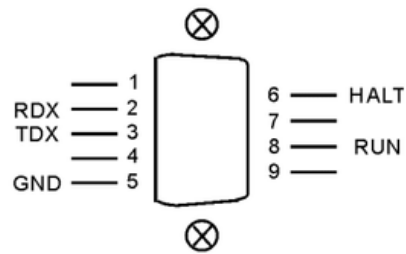

CN6 DB9(hole) RS232 communication				
signal	pin	I/O	function	availabilit
0V	5	OUT	0V	0V
RXD	2	IN	RXD	
TXD	3	OUT	TXD	
RUN	8	IN	run	0V
HALT	6	IN	pause	0V

CN6 connect fig:

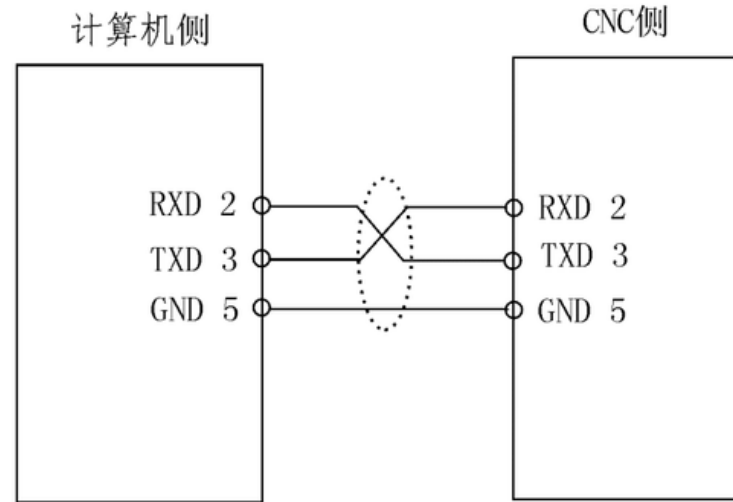

#### 5.4.4 CN3 and machine electric device I/O1 connection

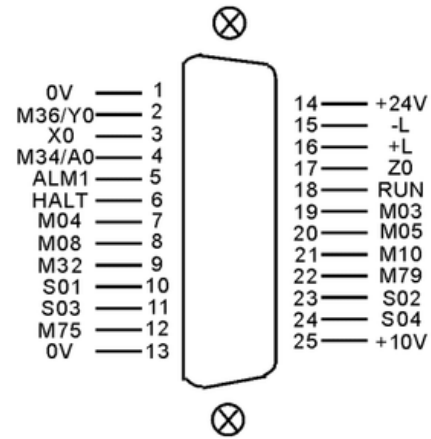

CN3 DB25(hole) I/O1 machine signal				
signal	pin	I/O	function	availabilit
0V	1	OUT	0V	0V
+24V	14	OUT	+24V	+24V
M36/Y0	2	IN	M36/Y0	0V
X0	3	IN	X axis Zero	0V
Z0	17	IN	Z axis Zero	0V
-L	15	IN	Positive limit	0V
+L	16	IN	Negative limit	0V
M34/A0	4	IN	M34/A0	0V
ALM1	5	IN	Transducer alarm1	0V
HALT	6	IN	Pause	0V
RUN	18	IN	Run	0V
M03	19	OUT	spindle clockwise	0V

M04	7	OUT	SP counter clockwise	0V
M05	20	OUT	SP stop	0V
M08	8	OUT	coolant	0V
M10	21	OUT	spindle chuck	0V
M32	9	OUT	lubricating	0V
M79	22	OUT	spindle tailstock	0V
S01	10	OUT	spindle first gear	0V
S02	23	OUT	spindle second gear	0V
S03	11	OUT	spindle third gear	0V
S04	24	OUT	spindle fourth gear	0V
M75	12	OUT	C axis mode	0V
+10V	25	OUT	the first spindle converting	0~10V
0V	13	OUT	0V	0V

### 5.4.5 CN10 and machine electric device I/O2 connection

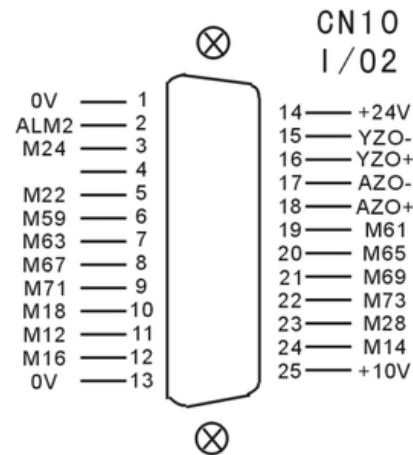

CN10 DB25(hole) I/O2 machine signal				
signal	pin	I/O	function	availability
0V	1	OUT	0V	0V
+24V	14	OUT	+24V	+24V
ALM2	2	IN	Machine alarm2	0V
M24	3	IN	M24	0V
M22	5	IN	M01 input	0V
M59	6	OUT	Huff	0V
M61	19	OUT	M61	0V
M63	7	OUT	M63	0V
M65	20	OUT	M65	0V

M67	8	OUT	M67	0V
M69	21	OUT	M69	0V
M71	9	OUT	M71	0V
M73	22	OUT	M73	0V
M18	10	IN	M18	0V
M28	23	IN	M28	0V
M12	11	IN	M12	0V
M14	24	IN	M14	0V
M16	12	IN	M16	0V
YZO+	16	IN	+Ymotor Zero signal	5V
YZO-	15	IN	-Ymotor Zero signal	
AZO+	18	IN	+Amotor Zero signal	5V
AZO-	17	IN	-Amotor Zero signal	
+10V	25	OUT	the second spindle converting	0~10V
0V	13	OUT	0V	0V

#### 5.4.6 CN5 and servo drive & motor connection

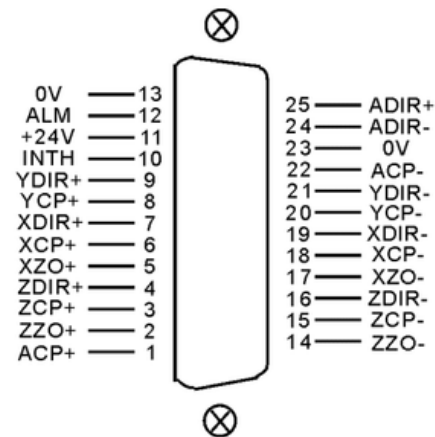

CN5 DB25(pin) servo drive signal				
signal	pin	I/O	Function	Availability
XCP+	6	OUT	X pulse signal +	5V
XCP-	18	OUT	X pulse signal -	
XDIR+	7	OUT	X direction signal +	5V

XDIR-	19	OUT	X direction signal -	
YCP+	8	OUT	Y pulse signal +	5V
YCP-	20	OUT	Y pulse signal -	
YDIR+	9	OUT	Y direction signal +	5V
YDIR-	21	OUT	Y direction signal -	
XZO+	5	IN	X motor Zero +	5V
XZO-	17	IN	X motor Zero -	
ZCP+	3	OUT	Z pulse signal +	5V
ZCP-	15	OUT	Z pulse signal -	
ZDIR+	4	OUT	Z direction signal +	5V
ZDIR-	16	OUT	Z direction signal -	
ZZO+	2	IN	Z motor Zero +	5V
ZZO-	14	IN	Z motor Zero -	
ACP+	1	OUT	A pulse signal +	5V
ACP-	22	OUT	A pulse signal -	
ADIR+	25	OUT	A direction signal +	5V
ADIR-	24	OUT	A direction signal -	
0V	13、23	OUT	0V	0V
ALM	12	IN	Servo alarm	0V
+24V	11	OUT	+24V	24V
INTH	10	OUT	Clear alarm	0V

CN5 X、Z connect to our Co.' S servo drive:

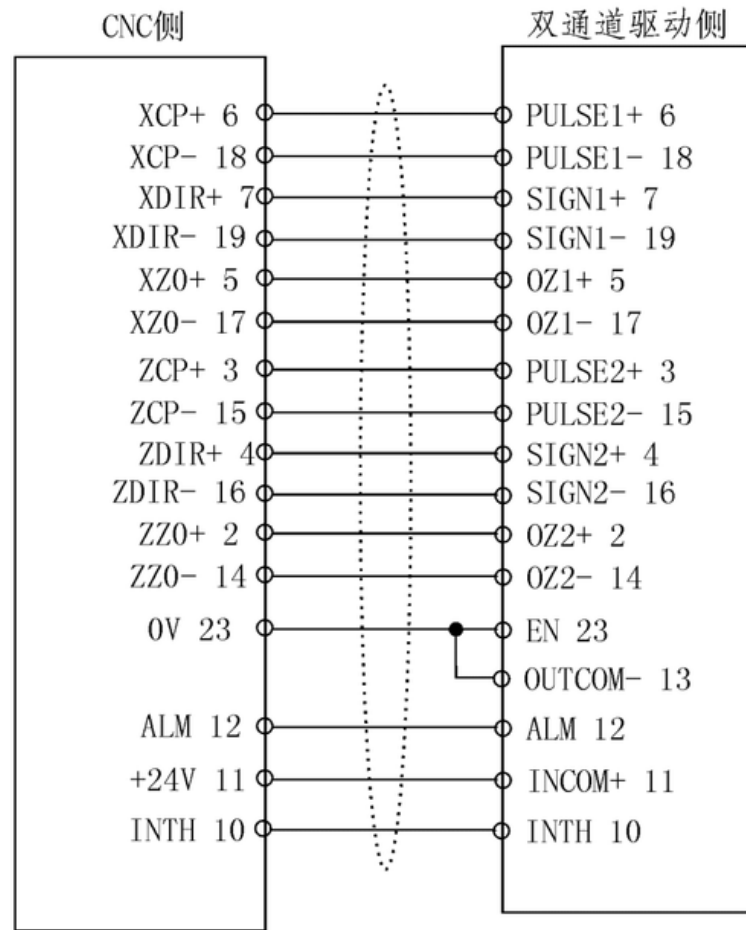

Servo alarm signal:

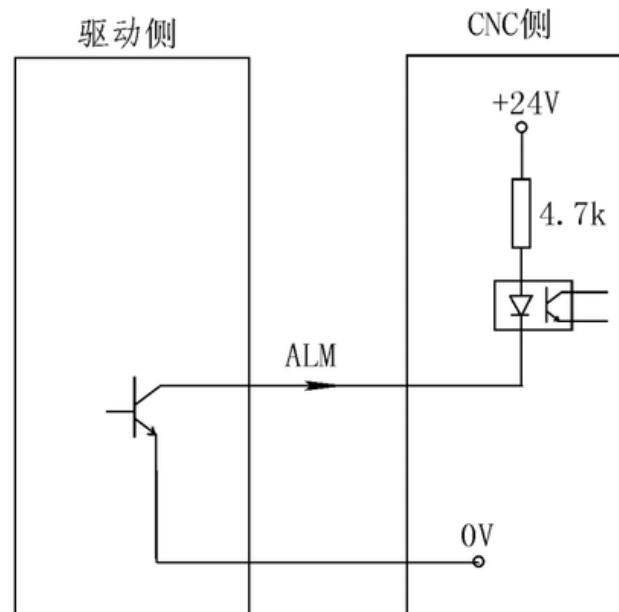



### 5.4.7 CN11 and hand wheel, band switch connection

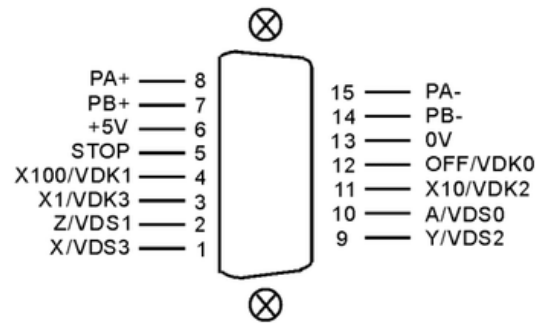

CN11 DB15(pin) hand wheel, band switch connection				
signal	pin	I/O	function	Availability
0V	13	OUT	0V	0V
+5V	6	OUT	+5V	+5V
PA+	8	IN	A signal +	5V
PA-	15	IN	A signal -	
PB+	7	IN	B signal +	5V
PB-	14	IN	B signal -	
STOP	5	IN	emergency stop	0V
OFF/VDK0	12	IN	Off/ feed amending 0	0V
X100/VDK1	4	IN	*100/ feed amending 1	0V
X10/VDK2	11	IN	*10/ feed amending 2	0V
X1/VDK3	3	IN	*1/ feed amending 3	0V
A/VDS0/HALT	10	IN	A/SP amending 0/halt stop	0V
Z/VDS1	2	IN	Z/SP amending 1	0V
Y/VDS2/RUN	9	IN	Y/SP amending 2/run	0V
X/VDS3	1	IN	X/SP amending 3	0V

#### 5.4.7.1 hand wheel

When “Other parameter” P1=1, It will be pend handwheel, and do not use band switch. “Axis parameter” P1=0, P2=0. “Other parameter” P33=0, P34=0. Input sigal A、X、Y、Z、X1、X10、X100 is choice switch.

Handwheel contact diagrammatic as:

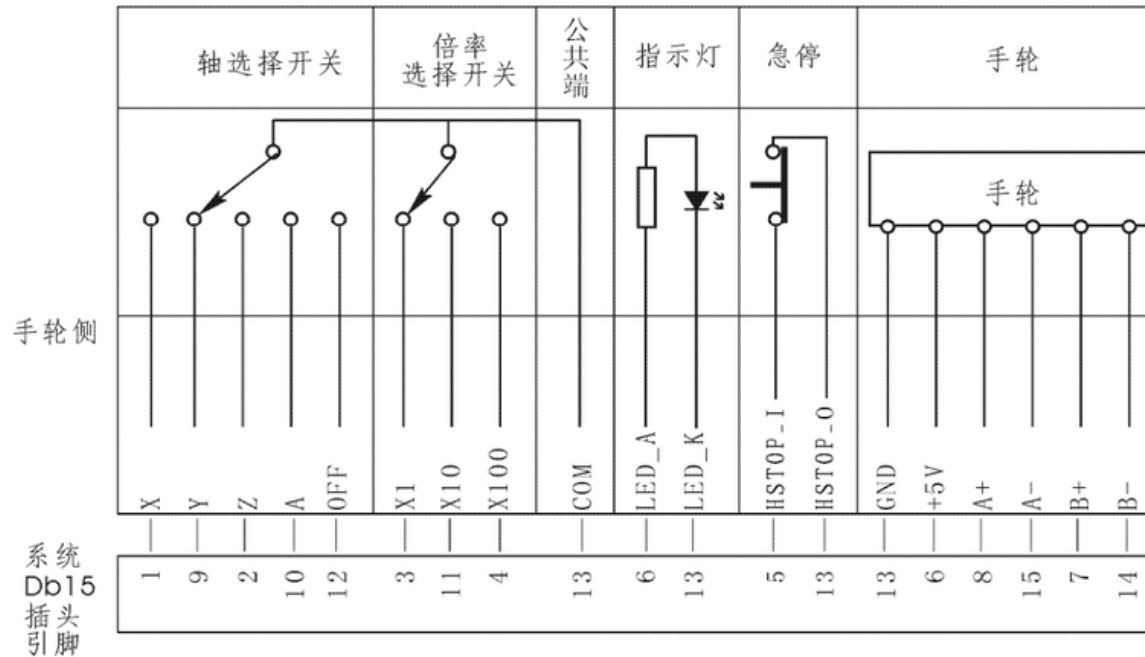

### 5.4.7.2 Band switch

When “Axis parameter” P1=1、P2=1, It will be band switch. and do not use pend handwheel. “Other parameter” P1=0、P33=0、P34=0. Input sigal VDS0(A)、VDS1(Z)、VDS2(Y)、VDS3(X) are spindle speed adjust switch. VDK0(OFF)、VDK1(X100)、VDK2(X10)、VDK3(X1) are G01/G02/G03 speed adjust switch.

### 5.4.7.3 Emergency Stop

STOP sigal is extemal emergency stop input sigal. “Other parameter” P27 setup “CLOSE” or “OPEN” .

### 5.4.8 General, motion cotrol I/O output port principle which is availability by "0V"

Output port of Y00-Y23 are availability by “0V”, the connection method as follow (take Y00 cotrol relay as example):

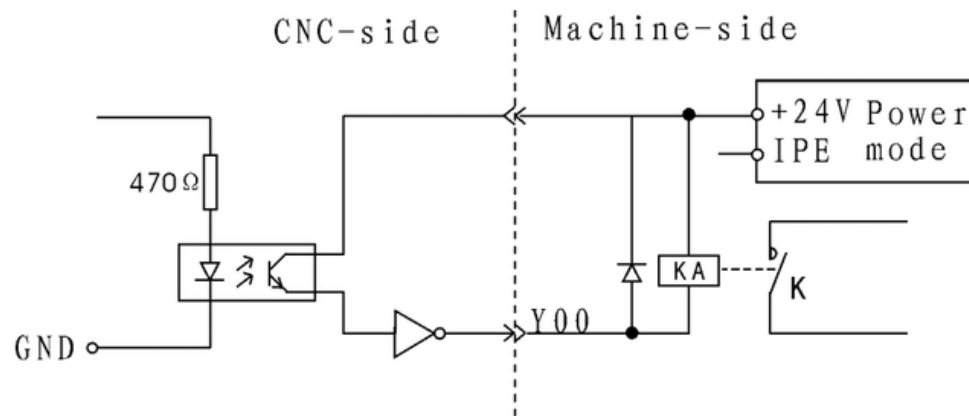

Specially pay attention: Because the output ports are the transistor output, thus the load electric current cannot be bigger than 150mA.

OUTPUT signal example M03 (M04、M05、M08、M10、M32、M79、M75、M59、M61、M63、M65、M67、M69、M71、M73、S01-S04) ;

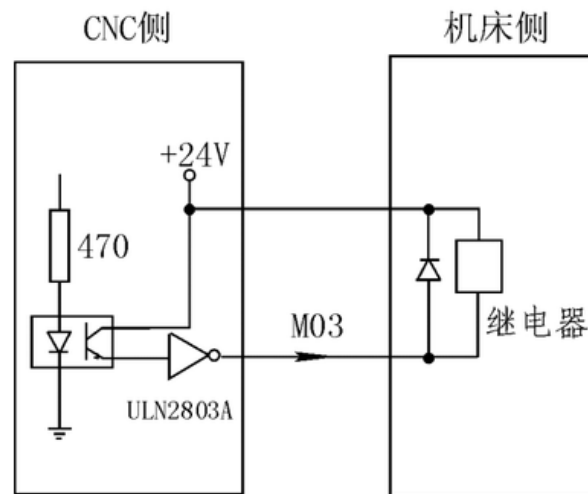

#### Notice:

1、IC ULN2803A control output signal:

1)、U28: M59、M61、M63、M65、M67、M69、M71、M73

2)、U29: M03、M04、M05、M08、M10、M79、M32、M75

3)、U30: +T、-T、S01、S02、S03、S04、LRUN、INTH

2、User-defined M71/M70、M73/M72 will maybe stuck control signal, "Other parameter" P20、P21 setup.

3、User-defined M65、M67、M69 will maybe stop\alarm\run output control signal; "Other parameter" P28、P29 setup.

4、All output signal is valid by 0V.

#### 5.4.8.1 CNC spindle control (M03/M04/M05)

**Axis parameter:**

- 7, Spindle stop time(10ms)
- 8, Spindle stop long signal  
[0 mean No, 1 mean Yes]
- 9, Check SP encode  
[1 mean Yes, 0 mean No]
- 10, SP encode pulse  
[4 times encode thread]
- 50, Have Spindle class control  
[1 mean open, 0 mean close]
- 51, Spindle class speed(1/100rpm)
- 52, Spindle class direction  
[0 mean M03, 1 mean M04]
- 53, Spindle class stop time(10ms)
- 54, Spindle class time(10ms)
- 55, Spindle stop time(10ms)
- 56, Spindle manual point M04 [8 mean M04]

**Speed parameter:**

- 8, Spindle`s manual speed(rpm)
- 36, Spindle first max speed(rpm)
- 37, Spindle second max speed(rpm)
- 38, Spindle third max speed(rpm)
- 39, Spindle forth max speed(rpm)
- 40, Second Spindle max speed(rpm)

**Other parameter:**

- 13, Does lock for Spindle & chuck(0 mean no)

#### 5.4.8.2 CNC lubrication control (M32/M33)

**Other parameter:**

- 4, Have auto lubricate(0 yes/1 no)
- 5, Auto lubricate time(0.01s)
- 6, Auto lubricate stop time(s)

#### 5.4.8.3 CNC stuck/ finial control (M10/M11、 M79/M78)

**Other parameter:**

- 2, lather outside chuck  
[1 extroversion, 0 diffidence]

- 13, Does lock for Spindle & chuck (0 mean no)
- 15, Chuck clamp M10/loose M11 checking (1 mean need)
- 16, Finial forward M79/backward M78 checking (1 mean need)
- 20, stuck control signal (0 single, 1 double M10/M71)
- 21, finial control signal (0 single, 1 double M79/M73)
- 22, Outside chuck control (0 no, 1 yes)
- 23, Outside finial control (0 no, 1 yes)
- 24, M10M11 short signal time (s)
- 25, M79M78 short signal time (s)

## 5.4.9 Reference points connections in/out port principle

### 5.4.9.1 Tool Limit

Take +L、-L axis as example

Model: NPN approach switch

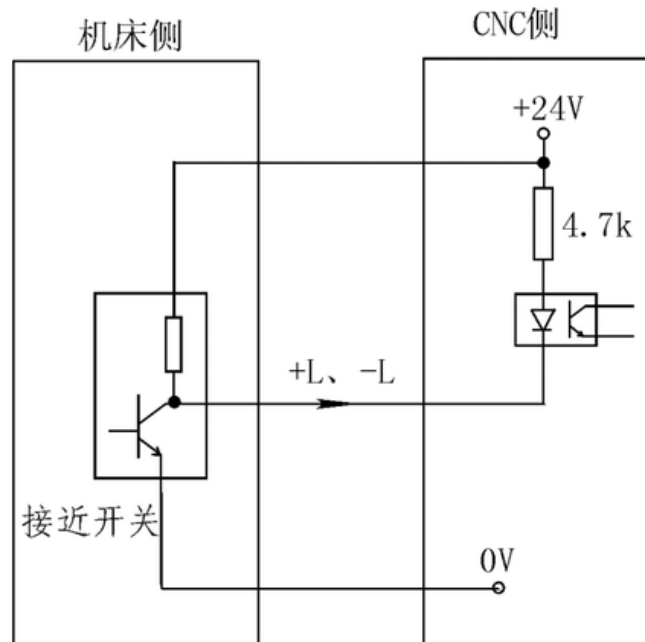

Mode2: general switch

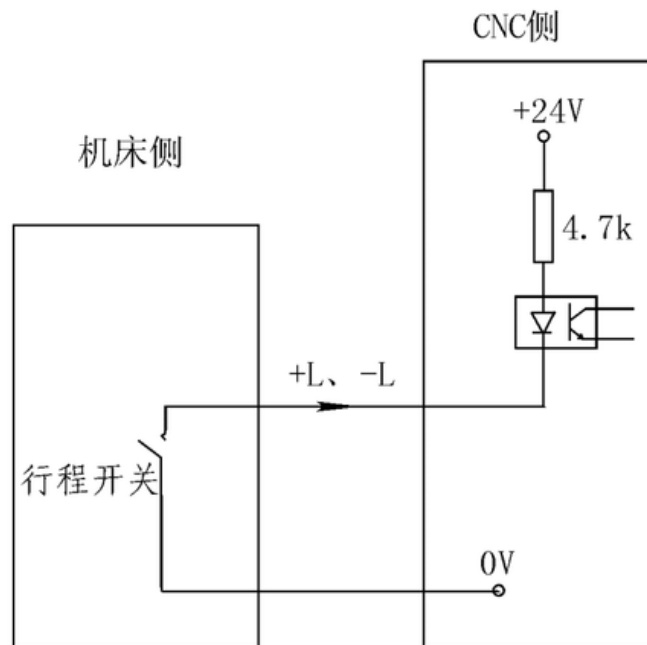
**Axis parameter:**

21, XZ positive limit

[0 open, 1 close]

22, XZ negative limit

[0 open, 1 close]

**5.4.9.2 Tool Reference zero**

Take X0、Z0 axis as example

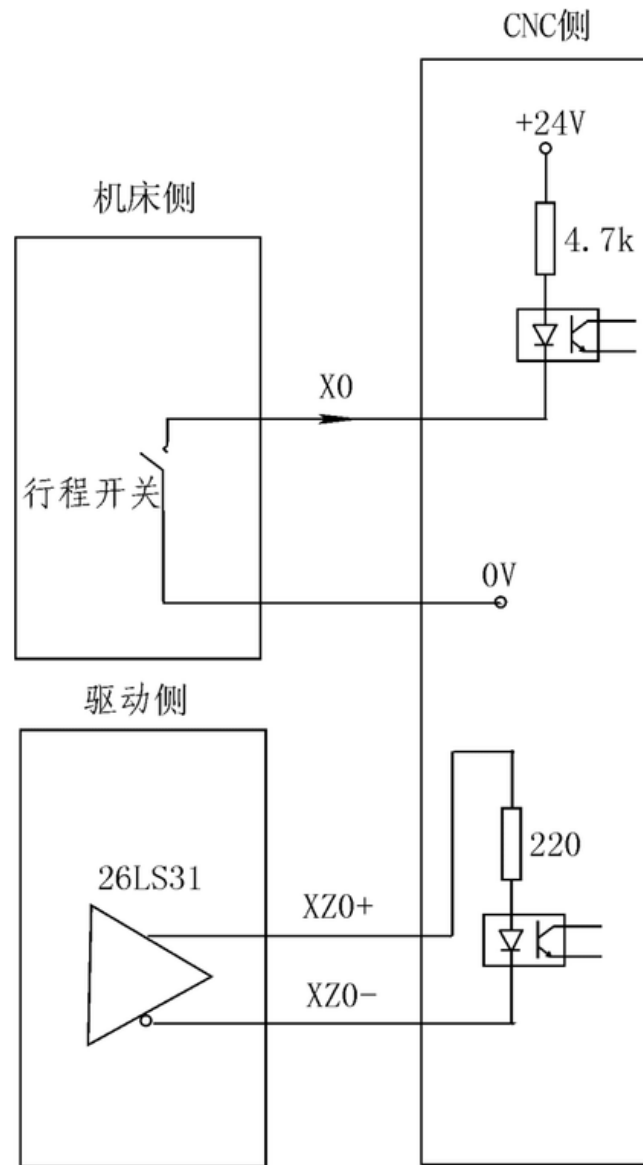
**Axis parameter:**

23, float zero bit paramter

[D3X;D4C(Y);D5Z;D6A;0 mean machine Zero;1 mean float Zero]

24, X coor float zero set

25, Z coor float zero set

26, Feed axis home

[1 mean No use, 0 mean clew, 8 compulsion, 9 must compulsion]

27, Feed axis home mode

[0 reverse check, 1 reverse No check, 2 No reverse check, 3 No reverse No check]

28, Home reverse direction

[D2X;D3C(Y);D4Z;D5A;D8=1fristZ;0Positive;1Neqative]

29, Home switch set

```
[DOX;D1C(Y);D2Z;D3A;1Close;0 Open]
30,X check zero max lenth(100um)
[radius]
31,Z check zero max lenth(100um)
32,X Home offset(10um)
33,Z Home offset(10um)
```

#### 5.4.9.3 ALM、ALM1、ALM2、door alarm/M12、Emergency-stop

##### Other parameter:

```
7,Door switch checking M12(0 no,1 yes)
8,Door switch(0 open,1 close)
17,servo ALM1 (0 open,1 close)
18,SP ALM2 (0 open,1 close)
26,Emerge Stop(0 open,1 close)
27,Emerge Stop2(0 open,1 close)
28,Run status output M69 STOP output M65(0 invalid,1 valid)
29,Alarm status output M67(0 invalid,1 valid)
```

#### 5.4.9.4 User-defined M12 (M14、M16、M18、M28、M22、M24、 RUN、HALT、Emergency-stop) sigal contact mode

Model: general switch

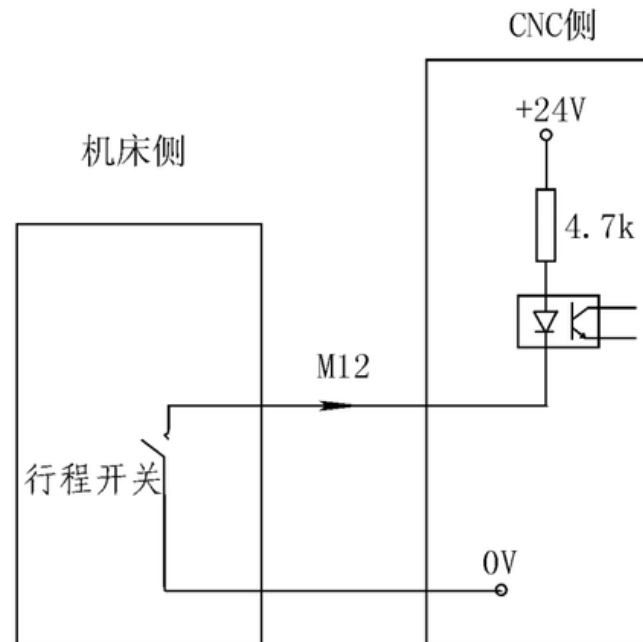

Mode2: NPN approach switch



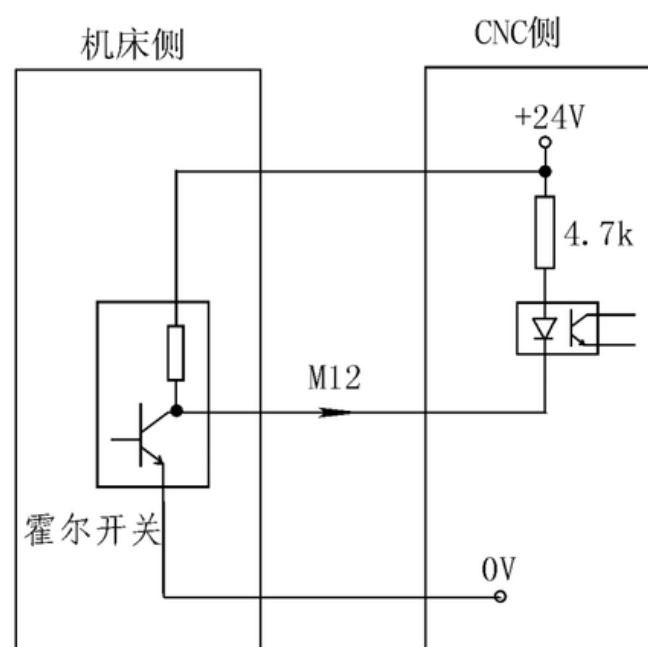

**Notice:**

- 1、M12、M14、M16、M18、M28 are multifunctional sigale, only use one.
- 2、All input sigal is valid by 0V.

## **Chapter 6 System's daily maintenance and repair**

In order to plenty use CNC system's function and promote efficiency, the most important work is correctly using system, and notice system's daily maintenance work, promote Mean Time Between Failures MTBF. Now this system's maintenance method is introduced as follows:

### **6.1 System's maintain**

6.1.1 System's using must be under the good circumstance.

6.1.2 Operator、programmer and repairer must be familiar with NC machining technology, and according the require of user book correctly use, do one's best to avoid improper operation.

6.1.3 Everyday operator should clean the system's box and panel in case for corrupt thing and sundries to damnify it.

6.1.3 When CNC system's using time is over three month, operator should open the system box and clean inside.

6.1.4 If not using system for long time, should boot the system one time every week.

### **6.2 Ordinary trouble**

#### **6.2.1 System can't boot**

- 1) check if power is normal.
- 2) check if power switch is turn on.
- 3) check insurance.

#### **6.2.2 No display as boot**

- 1) Boot again or reset.
- 2) Check if switch power's +5V、+12V、-12V、-24V are normal.
- 3) Check if transformer is bad.
- 4) Check if LCD's bright adjust and connection are normal.
- 5) Check if computer main board is normal.

#### **6.2.3 System's control disorganize**

- 1) Not correct operation.
- 2) The switch power's anti-jamming ability descend.
- 3) System's work circumstance become bad.

#### **6.2.4 User's program lose**

The DC battery on system main board can insure user's program and parameter don't lose. When system isn't used for half year or system has been used for over two years, the battery maybe invalidate, therefore, should exchange battery.

#### **6.2.5 Machining precision is bad**

- 1) CNC machine's reverse interval would change after using for a period of time, it needs to revise on time.
- 2) Best to revise base point before machining in order to insure the start point's precision.
- 3) Machining speed and cutting depth is improper.
- 4) Machine connector's prick melt falls off.
- 5) Tool isn't tightened.
- 6) Piece clamp isn't good.
- 7) Tool's giving up isn't equality because piece's dimension isn't uniformity.
- 8) Machine problem.

## Chapter 7 Appendix

### Appendix: binary、decimal switch table (0 — 15)

decimal	binary D7 .....D0	decimal	binary D7 .....D0
0	0 0 0 0 0 0 0 0	8	0 0 0 0 1 0 0 0
1	0 0 0 0 0 0 0 1	9	0 0 0 0 1 0 0 1
2	0 0 0 0 0 0 1 0	10	0 0 0 0 1 0 1 0
3	0 0 0 0 0 0 1 1	11	0 0 0 0 1 0 1 1
4	0 0 0 0 0 1 0 0	12	0 0 0 0 1 1 0 0
5	0 0 0 0 0 1 0 1	13	0 0 0 0 1 1 0 1
6	0 0 0 0 0 1 1 0	14	0 0 0 0 1 1 1 0
7	0 0 0 0 0 1 1 1	15	0 0 0 0 1 1 1 1

**Note:** Because of many kinds of reasons this Manual book may have some mistakes. Our company will provide the high quality service and the technical support for every customer.

