



PRADO

AUTOMAÇÃO INDUSTRIAL

Mach3 Ethernet Motion Controller EC500 User's Manual



Contents

1. Brief Description of the EC500 Motion Controller	1
2. Safety Notes	1
3. Physical Installation of the device	2
4. Controller EC500 Power Solution	3
5. Wiring and Ports Description	4
5.1 Ethernet Communication Interface to PC	5
5.2 Stepper/Servo Motor Control Interface Connection	7
5.3 Spindle Control Output Port	8
5.4 General output interface	9
5.5 Function Switch for MPG and Connection for MPG	11
5.6 Serial extend port	12
5.7 Input Ports	12
5.8 Power Supply for Controller System and Power Supply for IO Port	15
5.9 LEDs Indicator for Power and communication with Mach 3 software	15
6. Mach 3 Configuration	16
6.1 PlugIn	16
6.2 Open Mach3 Software and connect with right PlugIn file	16
6.3 Check EC500 Plug-In in the Mach3 software	17
6.4 Motor Tuning and Setup	18
6.5 Port and Pins Setup	19
6.6 MPG Settings	22

1. Description of the EC500 Motion Controller Device:

For firstly of all we thank you for your interesting in our product and for reading this user's guide.

The EC500 is a high-performace external motion controller for Mach3, with ethernet interface,supporting standard MPG pendant.The device can communicate with a connection to a control computer's network.The network connection can be built with direct connection or via router/Swith devices.

The computer connects to the EC500 via a standard Ethernet cable.The cable may be shielded or unshield-ed.An advantage of the Ethernet compared to a USB is that the cable length maybe as long as 100 meters.The maximum length for a USB cable is 5 meters,and that is pushing it in a noisy working environment.Another advantages is that Ethernet uses transformers for coupling the data signals,which galvanically isolates the computer from the downstream electronics.

The device can be used to control machine tools with stepper or servo motor controls with pulse and direc-tion interfaces;the controller can output a maximum of 460kHz stepping frequency for each axes and can work with upto 6-axes.The Controller is 3-6 Axis for user's options.

This user's guide describes how to establish connection between the device and controler computer,the device and stepper/Servo drives and spindle motor,how to setup the LAN network and the device for the communication.This document also describs the inputs and outputs,the electrical parameters and properties of the motion controller.It guides the users how to run the device with Mach3 software,and how to set the parame-ters in the software.

Here is the brief description for the device:

- 1) Motion control 3-6 Axis(X,Y,Z,A,B,C) for option,max frequency output 460Khz/Axis;
- 2) Main power supply 24VDC,Current should higher than 1A;
- 3) IO Power is 24VDC power supply input,current should higher than 1A;
- 4) IO Power is 24VDC power supply input,current should higher than 1A. (By the IO power supply,system already supply the power for IO ports.So no need the external power supply for IO port anymore.);
- 5) 18 opto-isolated digital input ports,16 opto-isolated digital output ports;
- 6) 1 analog output port of 0-10V adjustable speed for spindle (can change to PWM output port);
- 7) ARM motion control chip;
- 8) Compatible with Standard MPG and also Digital Dream MPG

Accessories:

Beside the main products,in our package,there are accesories:1pcs 1.5meter Ethernet cable.

2. Safety Notes:

Moving objets like machine tool axes and automatical equipments can be very dangerous.Always make sure to keep all machines safety standards.Always install E-stop switches and the required safety equipments to your control system and make sure that the equipment controlled by our device meets all the safety standards.

Always keep the controller dry and away from falling chips and dust,protect the device from taint damage.Avoid conneciton mistakes,avoid high voltage damage,avoid operation errors.

Protect the device from direct intensive sunshine beams and from extreme temperature levels and from extra high humidity weather.

We cannot take the responsibility for any persernal injury and financial loss caused by any device failure or caused by following an error in this documentation.

3. Physical Installation of the device(Unit:mm)

The EC500 motion controller is with the sealed shell structure,there are 4pcs mounting holes around the controller.We can fix 4pcs 4mm diameter holes at the cabinet,and install the controller into the cabinet.



Picture 3-1 EC500 Front Appearance and size

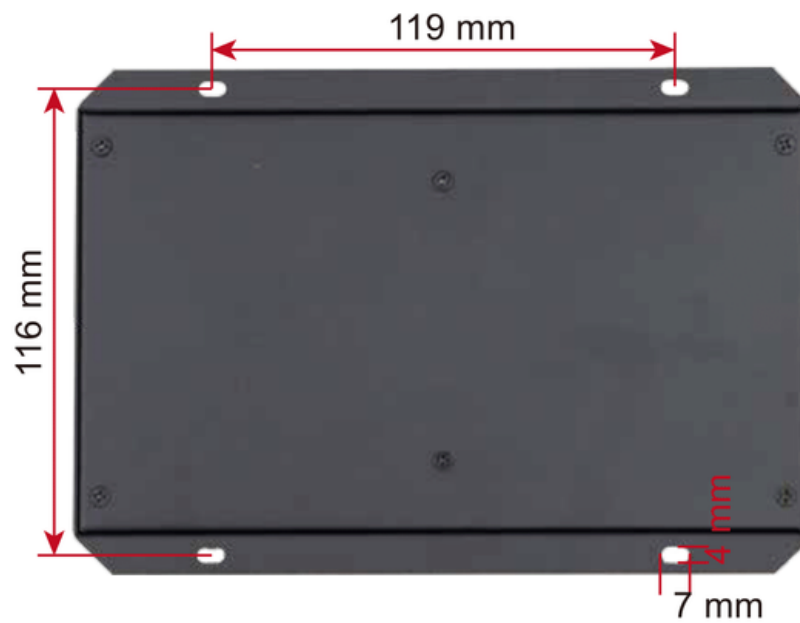

Picture 3-2 EC500 Installation Dimensions

4. Controller EC500 Power Solution

The power supply solution in the field of the Industrial automation is always very complicated, there is a lot of the GND, now we describe the structure of the power structure as below:

The power structure as the Picture 4-1, Power supply input and Ethernet port share common GND, stepper control module, Input&Output module, Spindle control module and MPG Port share common GND, between the two sector there is photoelectric isolation. Inside of the board, there is GND as common-, no need to connect external power supply.

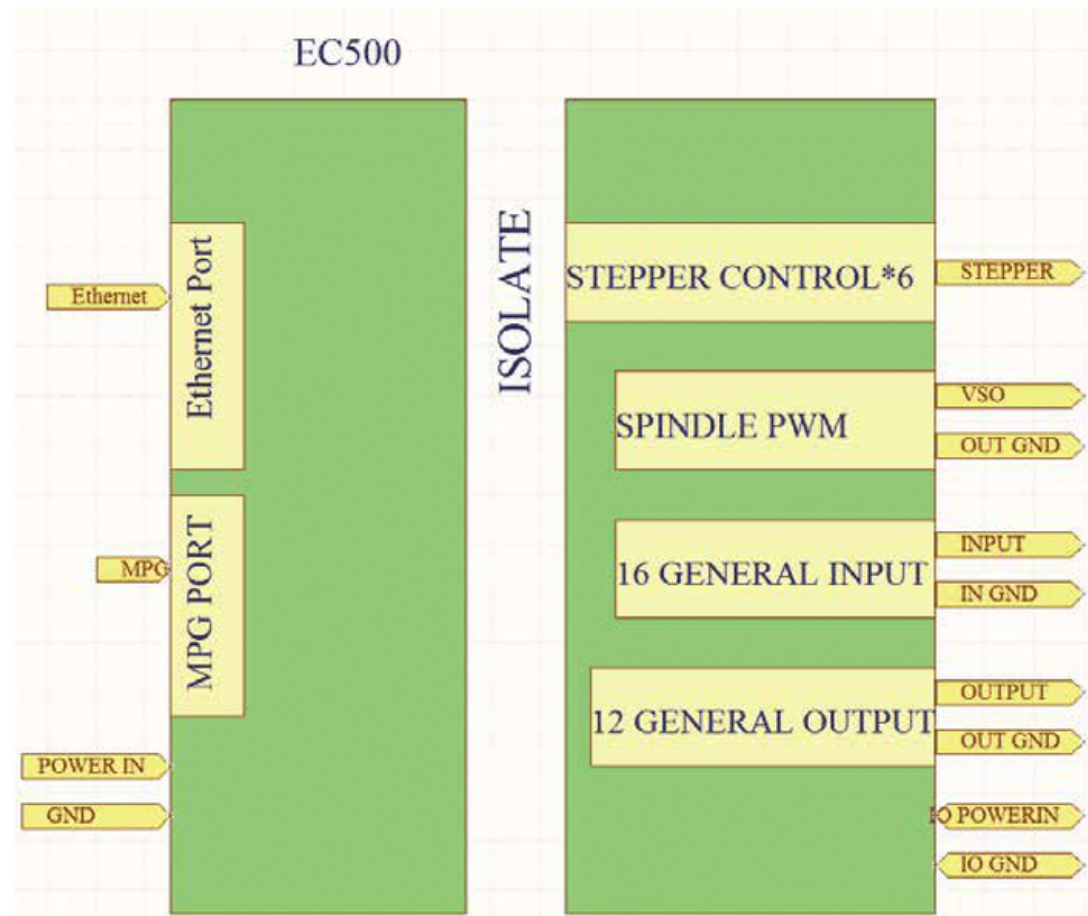

Picture 4-1 EC 500 Power supply structure

5. Wiring and Ports Description

The following drawing shows the main connections of our device. We will describe one by one in next pages. Here are:

- 1 : Ethernet Communication Interface to PC
- 2 : Stepper/Servo motor Driver connection port
- 3 : Spindle Control Output Port
- 4 : General Output Interface
- 5 : MPG Port
- 6 : Functional Switch for MPG: Standard MPG or Digital Dream MPG
- 7 : Serial Extend Port
- 8 : Input Port: Limit/Home/Probe and so on
- 9 : IO Power Port
- 10 : Main Power Port
- 11 : Power and Communication LED Indicator

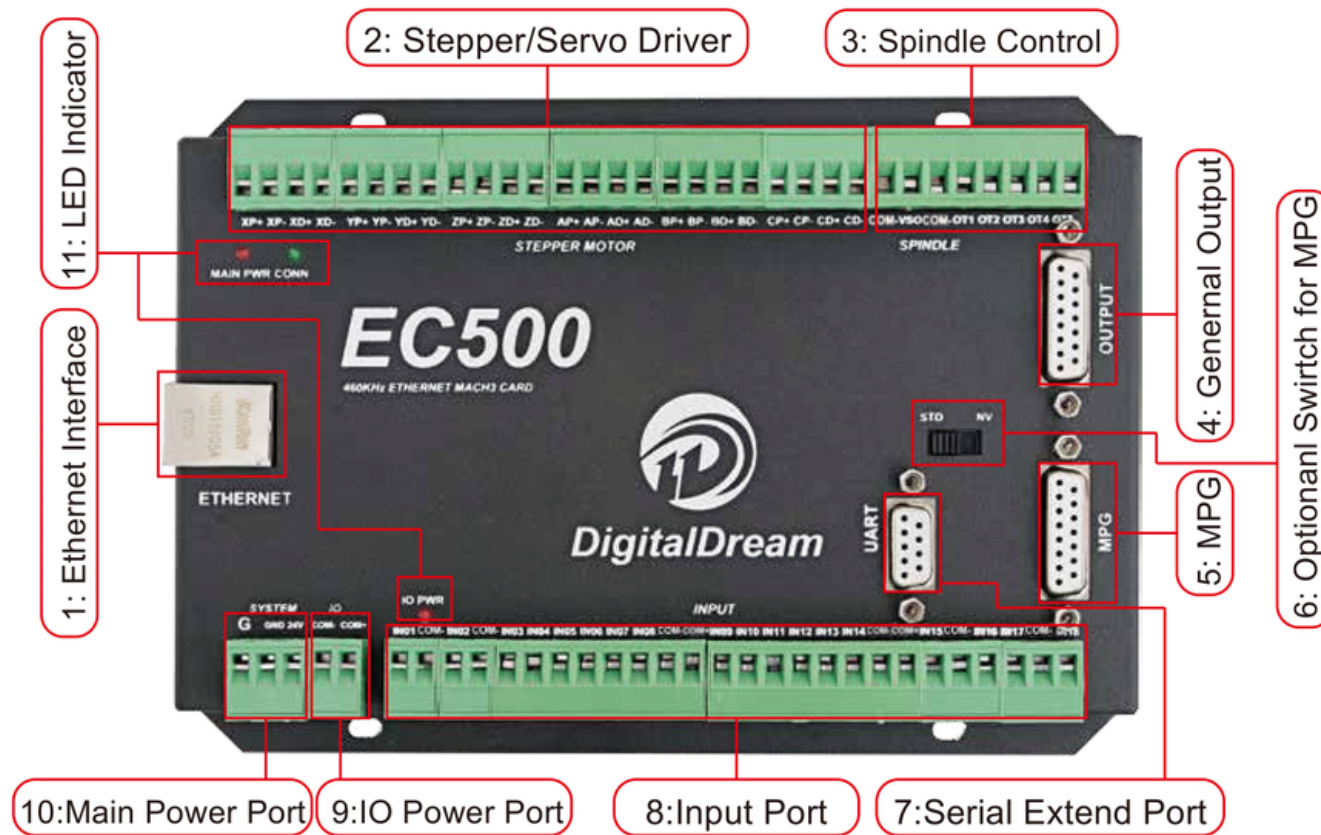

Picture 5-1 EC500 Wiring Over-view

5.1 Ethernet Communication Interface to PC

To setup the network on the computer side there are two ways for our device:

- 1) Setup with direct connection to a LAN network card;
- 2) Setup with connection via switch/router.

5.1.1 Setup with direct connection to a LAN network card.

Firstly connect the EC500 controller to PC by the ethernet cable.

To Setup the connection with direct cable connection click on the name of the connection and on the pop-up window press the Properties button. Please note that for this action to work the user must have administrator rights in Windows account. Control Panel -> Network and Internet -> Network Connections.

Pls remember to shut down the firewall of the computer before the connection.

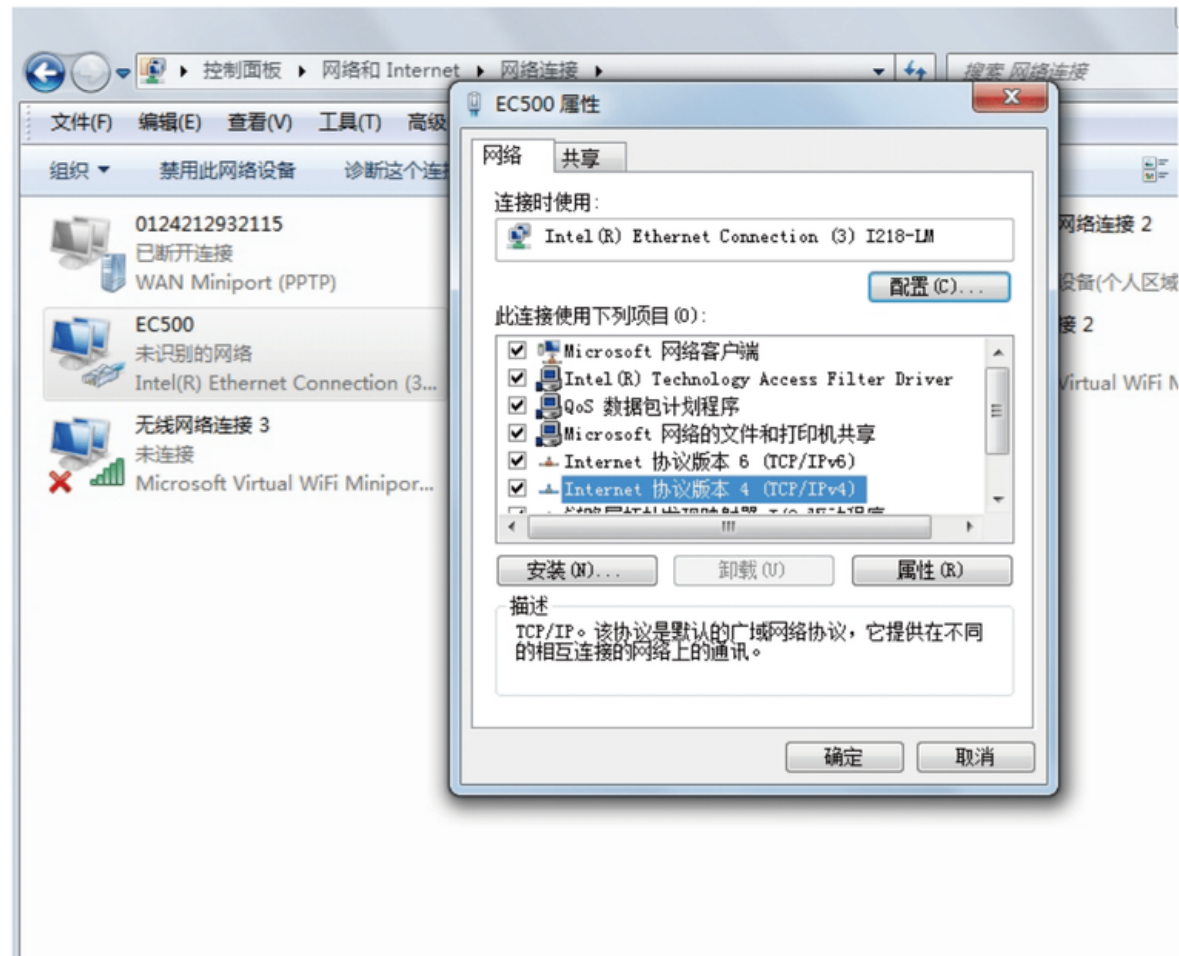

Picture 5-2 EC500 Ethernet Communication Setup

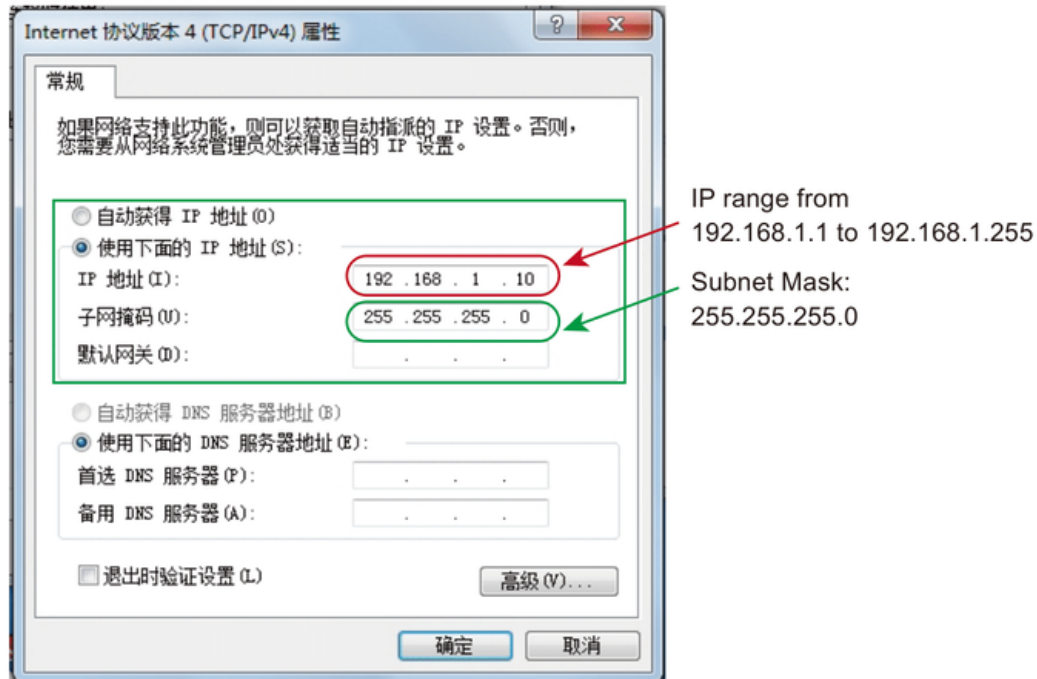

Picture 5-3 EC500 Ethernet Communication Setup IP No.

5.1.2 Setup with direct connection via switch/router.

To Setup the connection with connection via a switch or router device click on the name of the connection and on the pop-up window press the Properties button. Please note that for this action to work the user must have administrator rights in Windows account. On the popup window find and select the 'Internet Protocol Version 4(TCP/IPv4)' row and click the Properties button. Find and click 'Obtain an IP address automatically' and system will setup the connection.

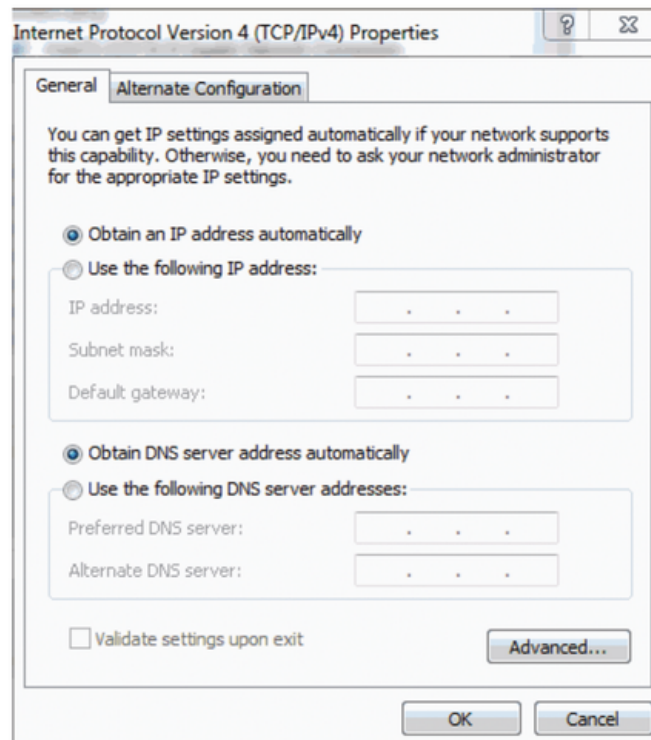

Picture 5-4 EC500 Ethernet Communication via switch/router

5.2 Stepper/Servo Motor Control Interface Connection



The device can be used to control machine tools with stepper or servo motor controls with pulse and direction interfaces upto 6-axes.

Motor Driver Connection(5V)	
PIN Mark	Description
XP+	X Axis Pulse Output +
XP-	X Axis Pulse Output -
XD+	X Axis Direction Output +
XD-	X Axis Direction Output -
YP+	Y Axis Pulse Output +
YP-	Y Axis Pulse Output -
YD+	Y Axis Direction Output +
YD-	Y Axis Direction Output -
ZP+	Z Axis Pulse Output +
ZP-	Z Axis Pulse Output -
ZD+	Z Axis Direction Output +
ZD-	Z Axis Direction Output -
AP+	A Axis Pulse Output +
AP-	A Axis Pulse Output -
AD+	A Axis Direction Output +
AD-	A Axis Direction Output -
BP+	B Axis Pulse Output +
BP-	B Axis Pulse Output -
BD+	B Axis Direction Output +
BD-	B Axis Direction Output -
CP+	C Axis Pulse Output +
CP-	C Axis Pulse Output -
CD+	C Axis Direction Output +
CD-	C Axis Direction Output -

Picture 5-5 EC500 Stepper/Servo Mark and description

5.3 Spindle Control Output Port

As Picture 5-1 showed, No.3 terminal block is for Spindle control output. We define the interface from left are COM-, VSO, COM-, OUT1, OUT2, OUT3, OUT4, OUT5. They are Ground of output, Speed adjusting voltage, Ground of output, Digital output1, Digital output2, Digital output3, Digital output4, Digital output5.

Take Nowforeuer inverter as the example. Spindle control output and the inverter connection showed as Picture 5-6. X1 control spindle Clockwise RUN and STOP, AIN1 modify spindle's speed. if we need to control spindle anti-clockwise RUN and STOP, we need to connect X2 to OUT2.

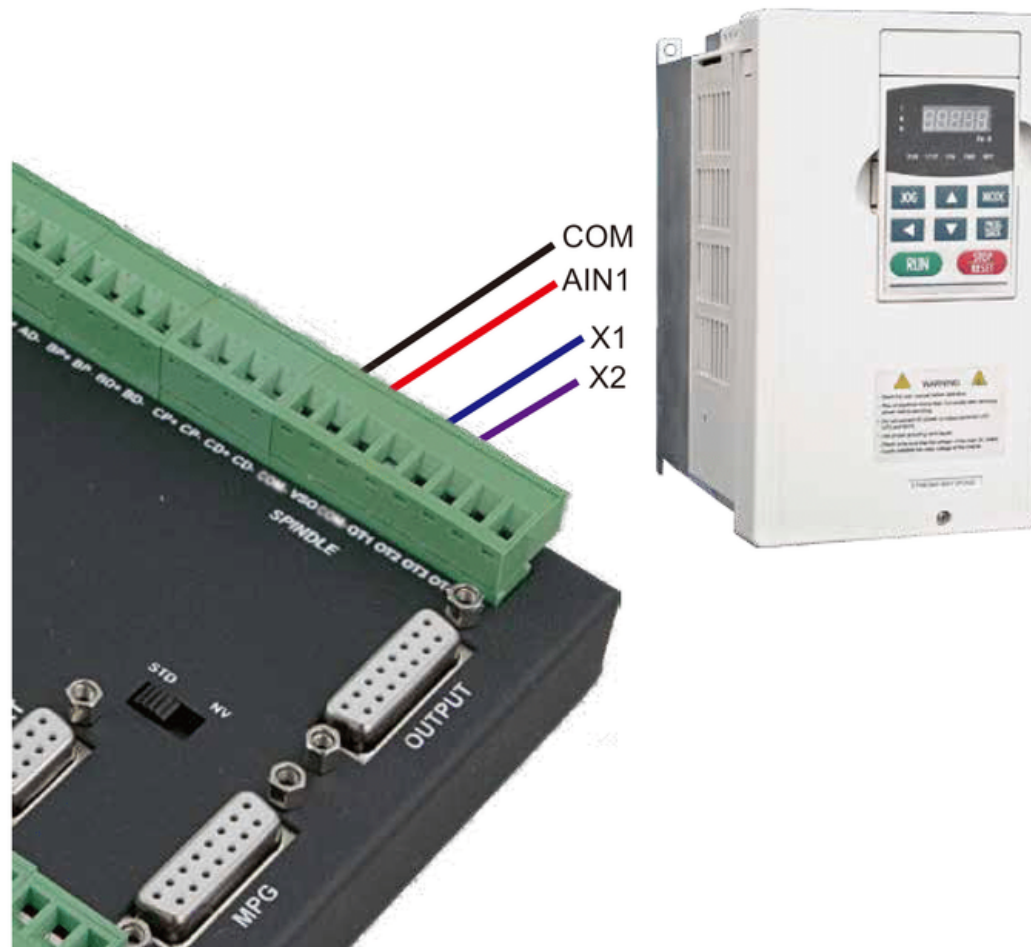

Picture 5-6 EC500 Spindle Control Setup

VSO connects to Speed adjustment which defined by voltage 0-10V.

The relationship Max. Spindle speed and current spindle speed is as below:

$VSO(\text{Output Voltage}) = 10 * \text{current spindle speed}(S) / \text{Maximum Spindle Speed}(\text{Max.S})$.

For example if we set the Max Speed is 24000, and we need the current spindle speed is 18000, then $VSO = 10 * 18000 / 24000 = 7.5V$.

The following picture 5-7 is the setting method of Max. speed in Mach3 software.



Picture 5-7 EC500 Spindle Motor Max Speed Setting

5.4 General output interface

As the Picture 5-1 showed, the marked No. 4 is General output interface. This is a DB15 port.

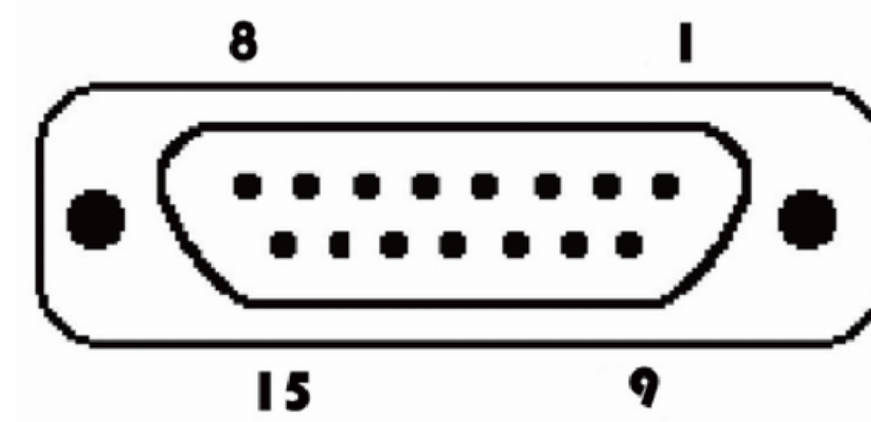

Picture 5-8 General Output DB15 Pin No.

PIN No.	Mark	Definition
1	COM+	IO power +
2	OUT6	OUTPUT 6
3	OUT8	IOOUTPUT 8
4	OUT10	OUTPUT 10
5	COM-	Common Ground for output
6	OUT13	OUTPUT13
7	OUT15	OUTPUT15
8	GND	Common Ground for output
9	VCCIO	IO power +
10	OUT7	OUTPUT 7
11	OUT9	OUTPUT 9
12	OUT11	OUTPUT 11
13	OUT12	OUTPUT 12
14	OUT14	OUTPUT 14
15	OUT16	OUTPUT 16

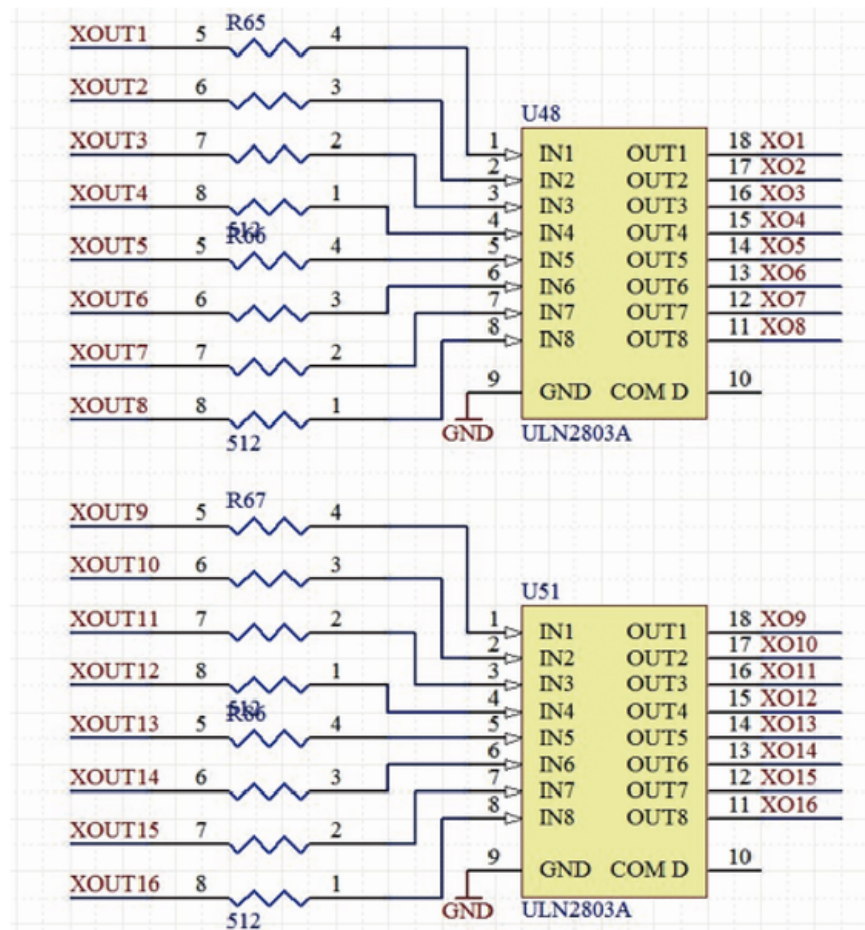

Picture 5-9 OUTPUT port internal structure

The general output interface has a built-in relay drive circuit, which can be directly connected to less than the 100mA relay. Reference Picture 5-10. for wiring with relay, using output 6 (Pin No.2).

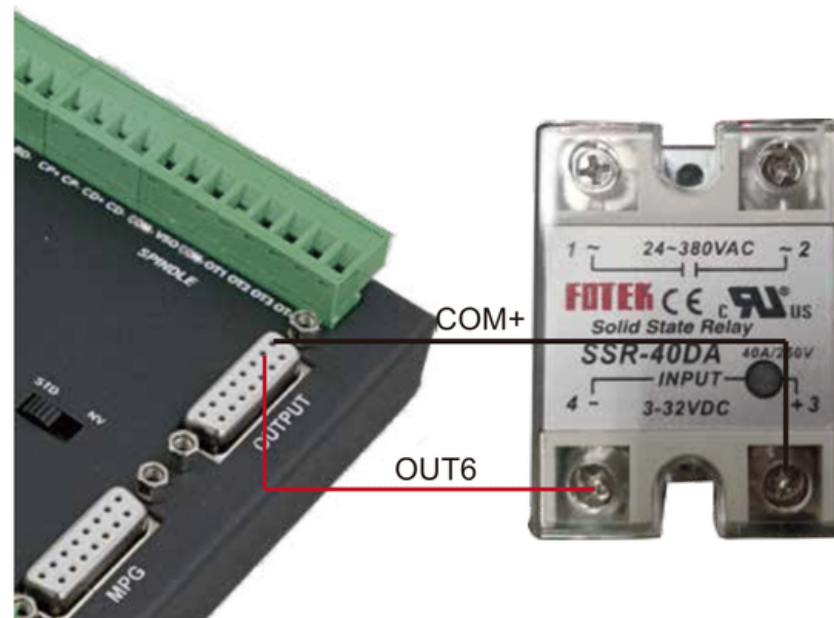

Picture 5-10 Solid Relay Connection

5.5 Function Switch for MPG and Connection for MPG

As the Picture 5-1 showed, the marked No.6 is the switch for the options of two type MPG. For EC500, it can supply both standard MPG and NV-MPG which is made by our company Digital Dream. The Marked No. 5 is the interface for the connection of MPG.

The difference connection for Standard MPG and NV-MPG is from the Pin1 and Pin 2. Pls check the following table. Pls don't also forget when you need standard MPG turns the switch to STD, and when you need NV-MPG, switch it to NV. Then wiring the connections of MPG interface.

MPG TYPE	STD(STANDARD MPG)		NV(NVMPG)	
PIN NO.	Mark	Definition	Mark	Definition
1	BIN	Select Axis B	T1OUT	OUT for serial port
9	CIN	Select Axis C	R1IN	IN for serial port

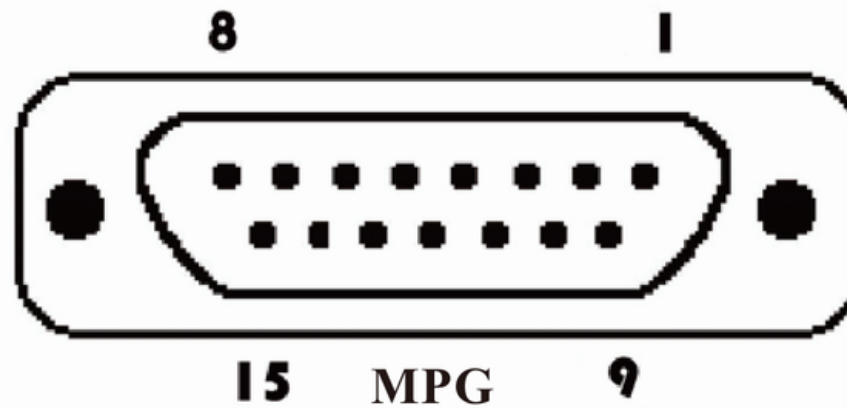

PIN No.	Mark	Definition
1	T1OUT	TXD of Serial port
2	VMPG	Power supply + for MPG(5V)
3	WHA+	A phase positive of the encoder
4	WHB+	B phase negative of the encoder
5	XIN	X axis select input
6	ZIN	Z axis select input
7	X100IN	100 rate select input
8	EP	Estop port
9	R1IN	RXD of Serial port
10	GND	Ground and common end
11	WHA-	A phase positive of the encoder
12	WHB-	B phase negative of the encoder
13	YIN	Y axis select input
14	AIN	A axis select input
15	X10IN	10 rate select input6

5.6 Serial extend port

As the Picture 5-1 show, The marked No. 7 port is Serial extend port. The interface is mainly used for extended serial devices, such as IO extensions or HMI interface extensions.

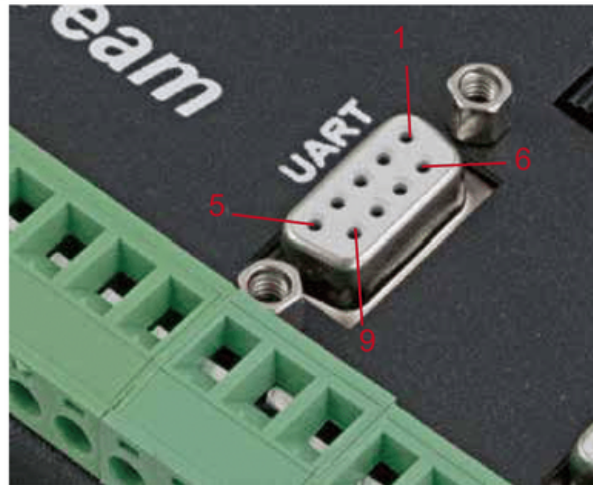

Picture 5-11 Extended Serial Port

PIN No.	Mark	Definition
1&6	VCC5	5V Power+
2	RXD	Receive for serial port
3	TXD	Transmit for serial port
5&9	GND	Ground
4&7&8	NC	Reserved

5.7 Input Ports

As the Picture 5-1 showed, Marked No. 8 position is for Input ports. They are the optical isolated Input interface. The Mark information from left to right is: IN1, COM-, IN2, COM-, IN3, IN4, IN5, IN6, IN7, IN8, COM-, COM+, IN9, IN10, IN11, IN12, IN13, IN14, COM-, COM+, IN15, COM-, IN16, IN17, COM-, IN18.

Internal structure see as Picture 5-12.

2 lines Proximity Switch/ordinary fretting switch / drawing see as Picture 5-13.

3 lines Proximity Switch connection Picture 5-14 and Picture 5-15, brown cable for Proximity switch connect with 12V, Black cable connect channel, blue cable connect with GND1. Pls note Only support NPN type 3 lines proximity switch.

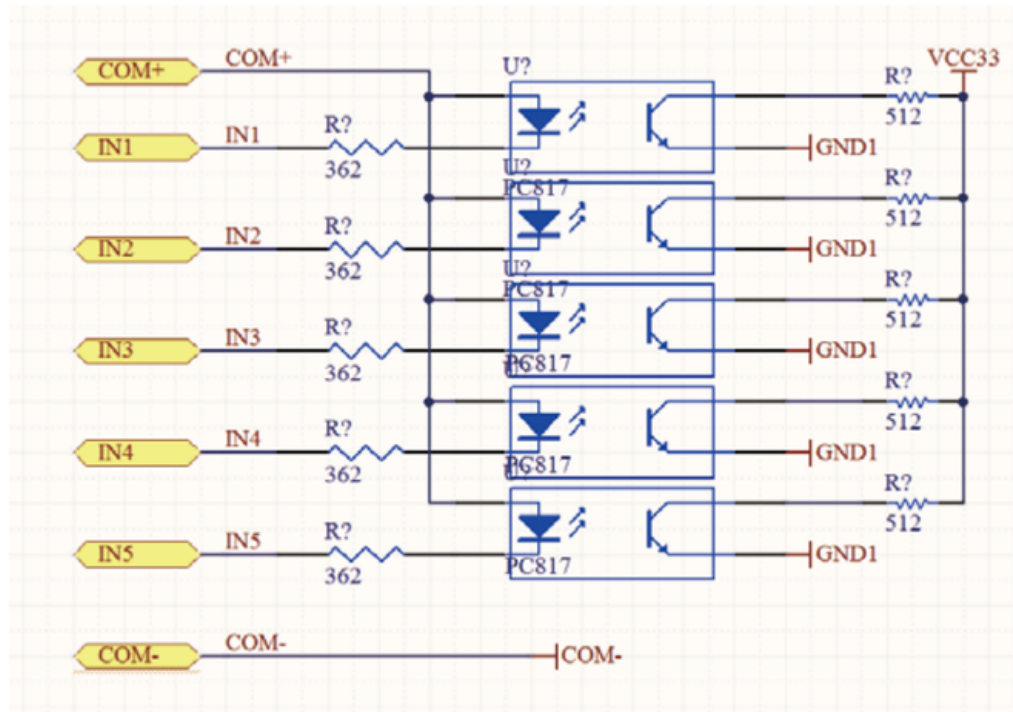

Picture 5-12 Internal structure of Input interface

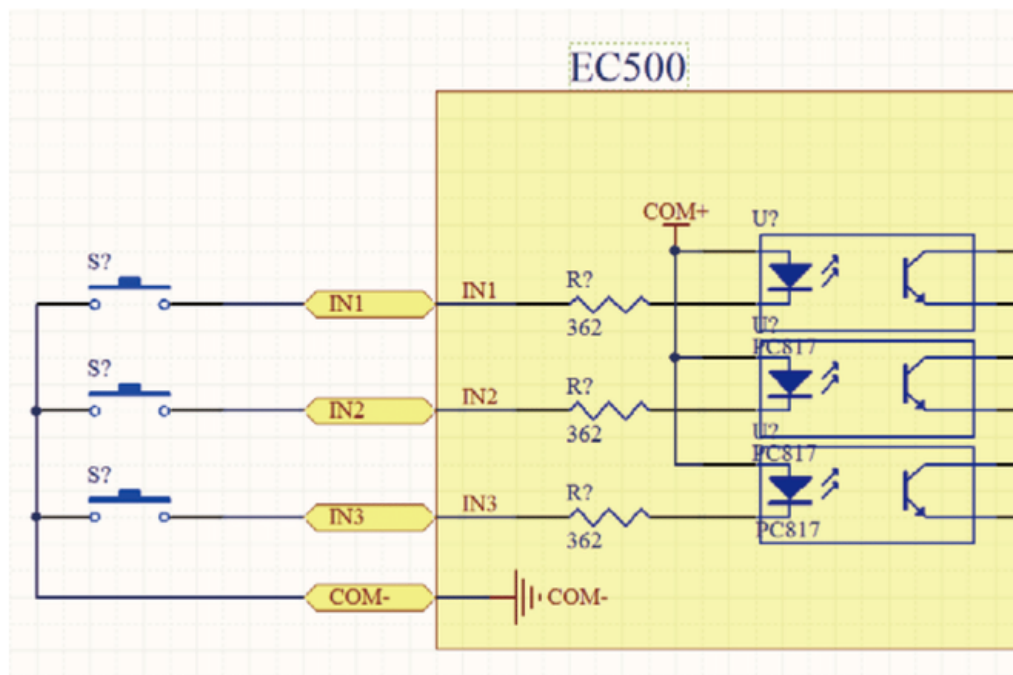

Picture 5-13 Probe/Estop/ and other switch input connection

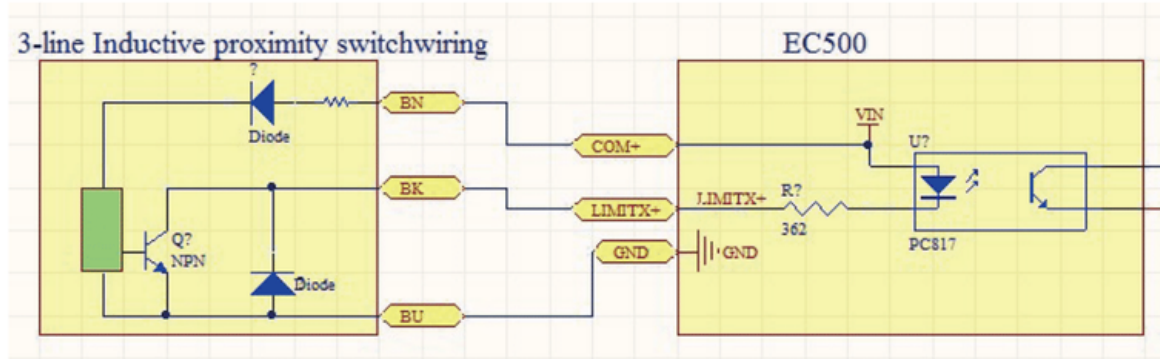

Picture 5-14 NPN 3 lines Proximity Switch connection drawing

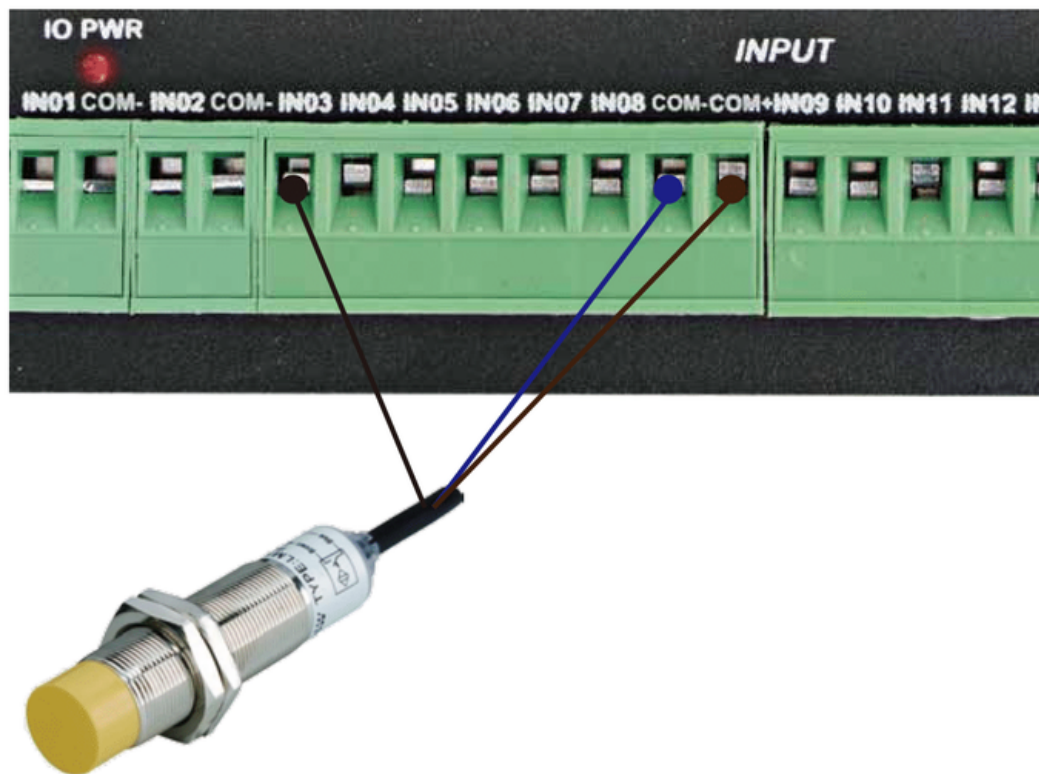

Picture 5-15 NPN 3 lines Proximity Switch Connection Example

5.8 Power Supply for Controller System and Power Supply for IO Port

As the Picture 5-1 show, The marked No. 9 port is the power supply port for IO port, and Marked No. 10 is for the power supply for Controller System. The access voltage range is 24VDC, and the power demand is not less than 20W. As shown in the picture, the left terminal is power - and the right terminal is power +, they shared one common GND. See the Picture 5-16 as below:

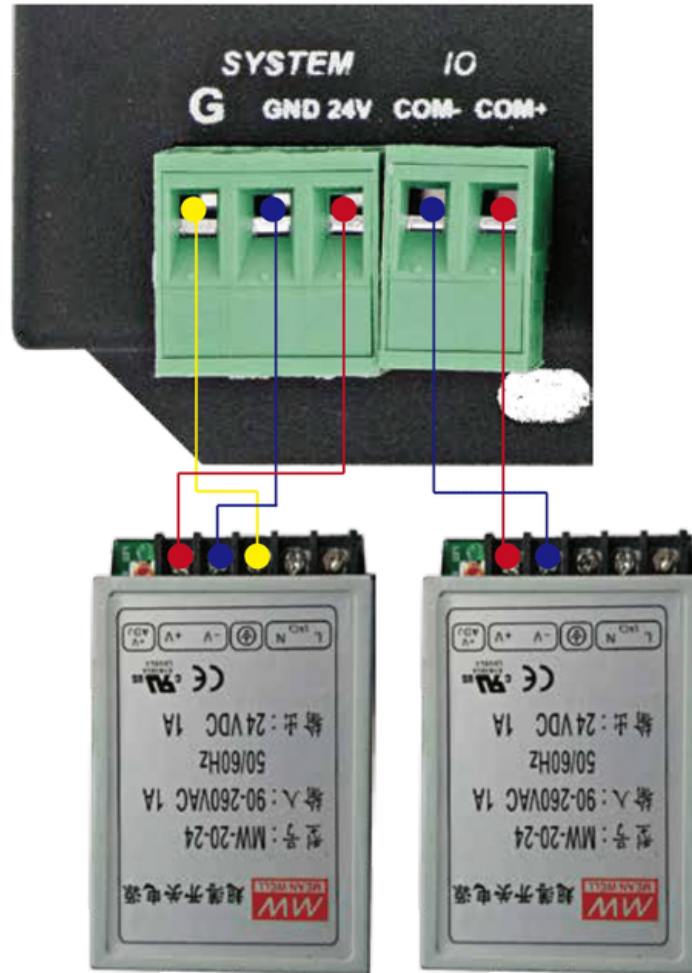

Picture 5-16 Power supply for Controller System and for IO Port

5.9 LEDs Indicator for Power and communication with Mach 3 software

As the Picture 5-1 show, There are 3 Indicator LEDs for the controller power, IO Power and communication with Mach3 respectively.

If the controller and IO power supply are configured in right way, the Main Power LED and IO Power LED turn to Red.

The LED marked "CONN" represents the status of the communication with Mach3 software. If a link has not been established, the LED will not light.

6. Mach 3 Configuration

6.1 PlugIn

When you purchase our product, we will supply a software package in the U-disk, which contains “DigitalDream” PlugIn, and the EC500 Manual.

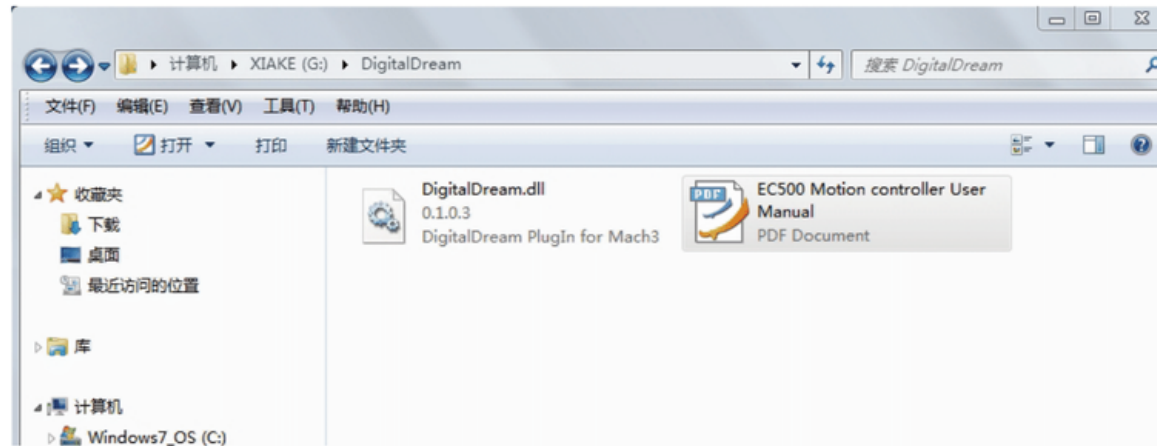

In your computer which you will run the EC500 controller, you must already installed the Mach 3 Software, and now pls copy the PlugIn in to C:\Mach3\PlugIn. (If the user install the Mach 3 software in C-disk.)

6.2 Open Mach3 Software and connect with right PlugIn file

Double-click the icon mach3mill  . Enter into Mach3 software. Pop-up the plug-in box as below left picture. Then Click “Create Profile” and name it to “DigitalDream”, click “Default profile values” and confirm it by “OK”

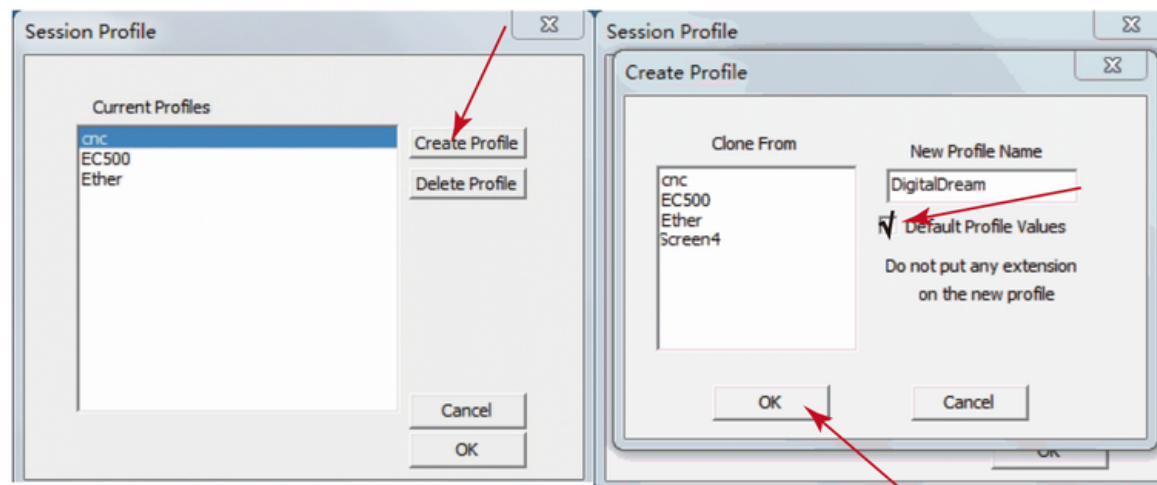

After Click “OK”,it will popup a window for the options of DLL file as below,pls choose “Digital Dream” as below.Then press OK. If you do not want to the dialog box to show again any more, select ‘Don’t ask me this again’.If connect successfully,Status bar will show “EC500 device is connected to your computer”.

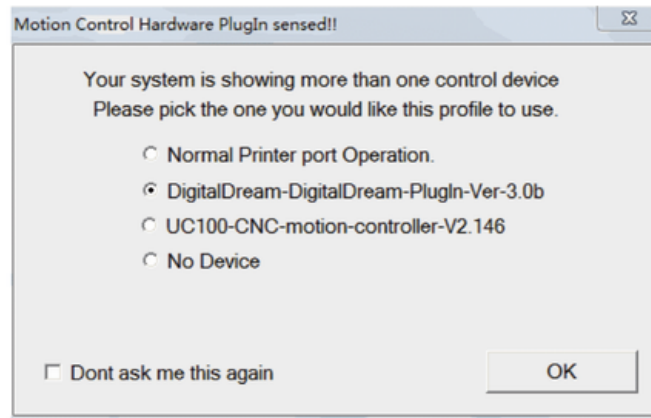

6.3 Check EC500 Plug-In in the Mach3 software

Click config plugins in the software main menu,in the pop-down menu select ‘PluginConfig’,it will show the DigitalDream Plug-In is enabled:

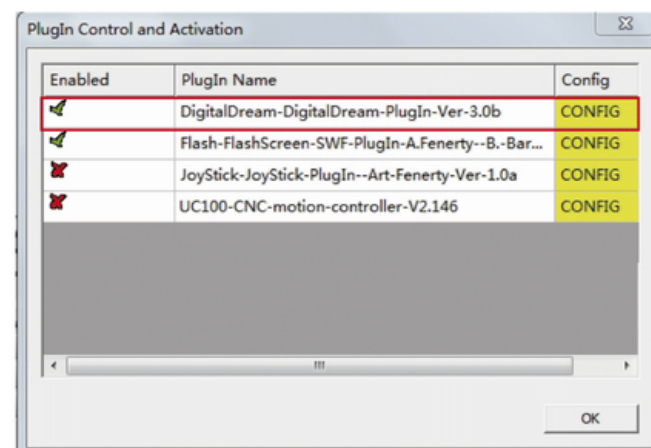
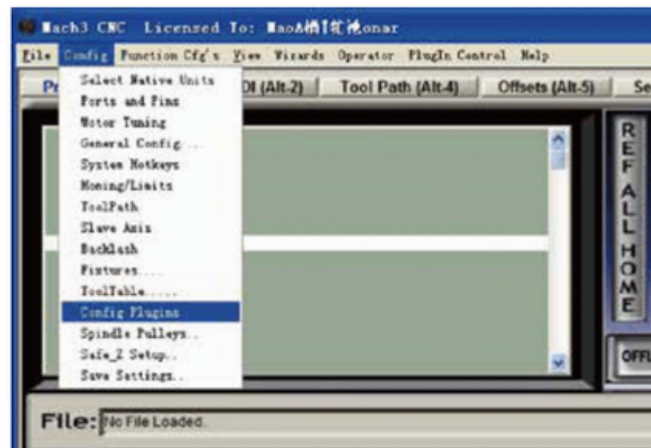

6.4 Motor Tuning and Setup

Click Main Menu 'Config', select the 'Motor Tuning' from its pop-down menu:

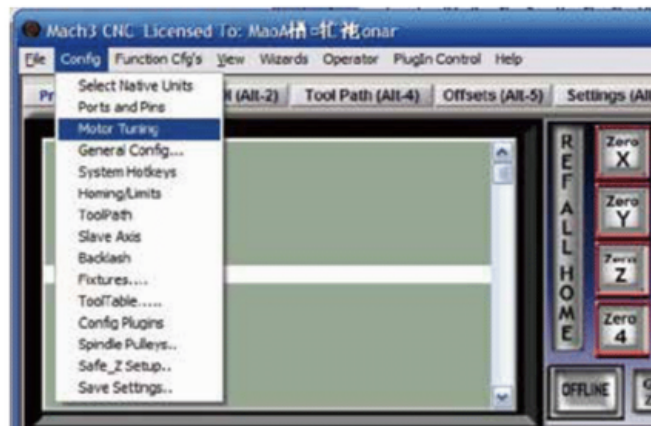

Then the screen display as below:

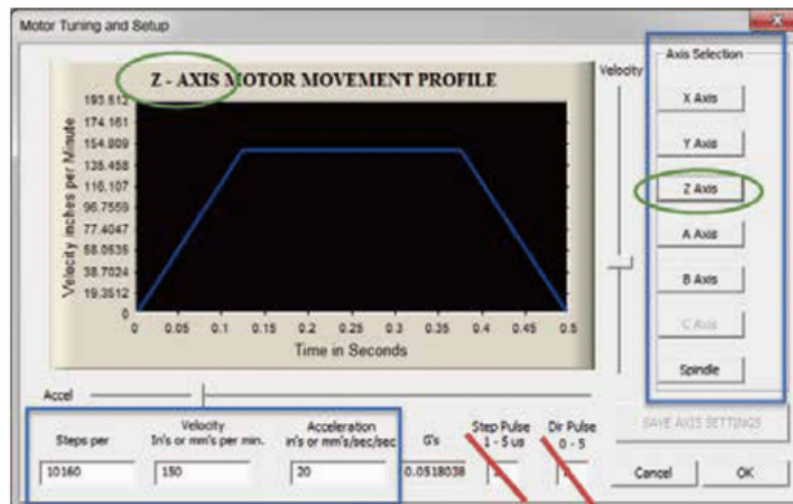

Mach3's Menu -> Config -> Motor Tuning (and Setup).

The Step Pulse and Direction Pulse fields are used for a Ethernet Port connection from your computer to your hardware.

The Steps per Unit, Velocity (Units per Minute) and Acceleration fields are critical for tuning your motors. The Steps per Unit is determined by your hardware for each axis. The velocity is the maximum speed you want your axis to move. The acceleration is the maximum acceleration rate your motors should run at (to prevent stalling or missed steps). This needs to be done for each of your axes.

Don't forget to save the data when you finished the data setting of every axis. For example, you click Z Axis, and save all the data into the column, then you must click "SAVE AXIS SETTING", then the data can be saved.

6.5 Port and Pins Setup

First, make sure you have your Motor Outputs assigned correctly (Menu -> Config -> Ports & Pins as below:

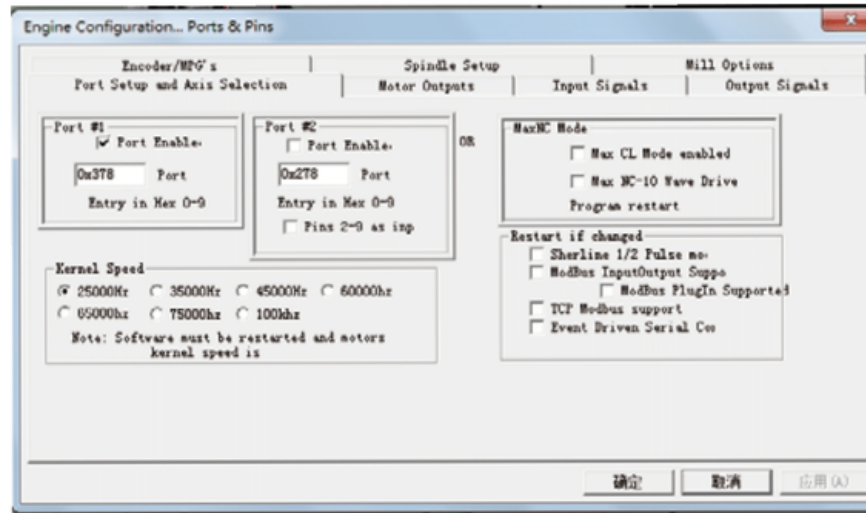

Then go to Right Lables: Motor Outputs and start to configurate as below:

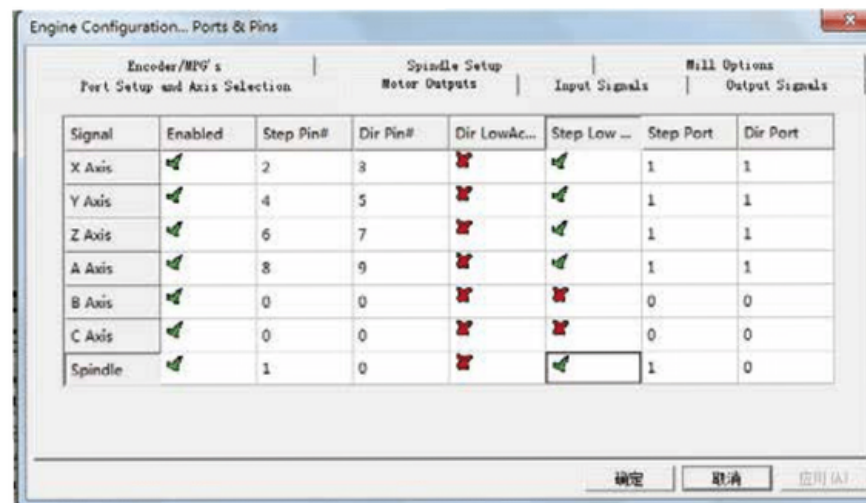

This page is to select the stepper motor control pins. Because Stepper motor control pins address are fixed by the controller board, So here only need to define the Pin address(No.s),we can define other parameters meter. To make sure the Z axis to the right direction(Up is '+',down is '-'), Z axis's "Dir low" should be set to"".Other axes's should be set as the user's request.

Second, make sure that you have your home switches assigned correctly (Menu -> Config -> Ports & Pins -> Input Signals). While you could use a single input for your X, Y, Z, and A homes, it is much better to have them as separate inputs! Our EC500 controller has plenty of inputs available and it allows Mach to home all of your axes at the same time if you wish (although you typically have your Z axis home after the rest of your axes so you don't crash your head).

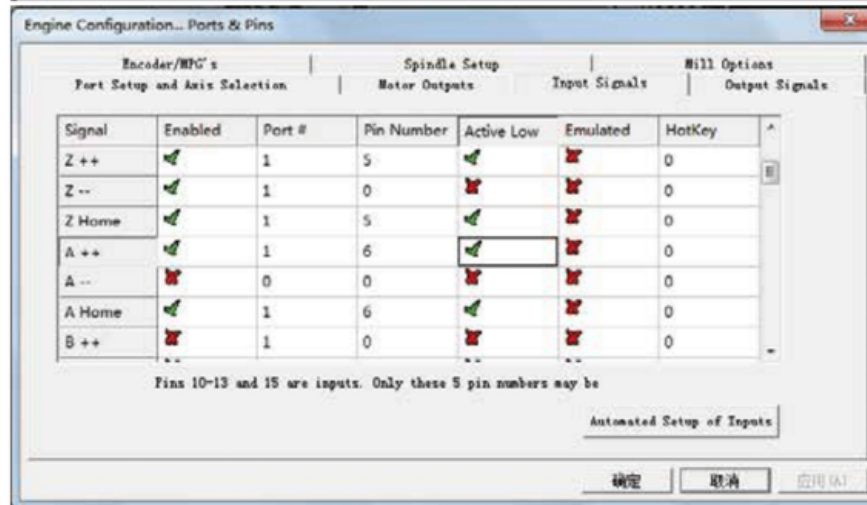
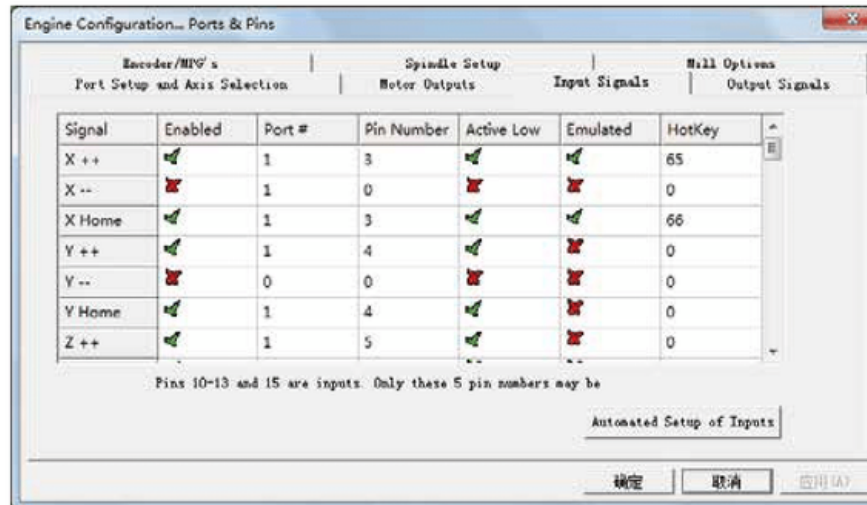

Here you can configure according to your actual needs the corresponding function. Optional Function include XYZABC 6axis's Upper and lower limit、XYZABC 6axis's HOME point. We set upper limit and home of XYZA to 3456 corresponding IN3/IN4/IN5/IN6 of the Controller board.

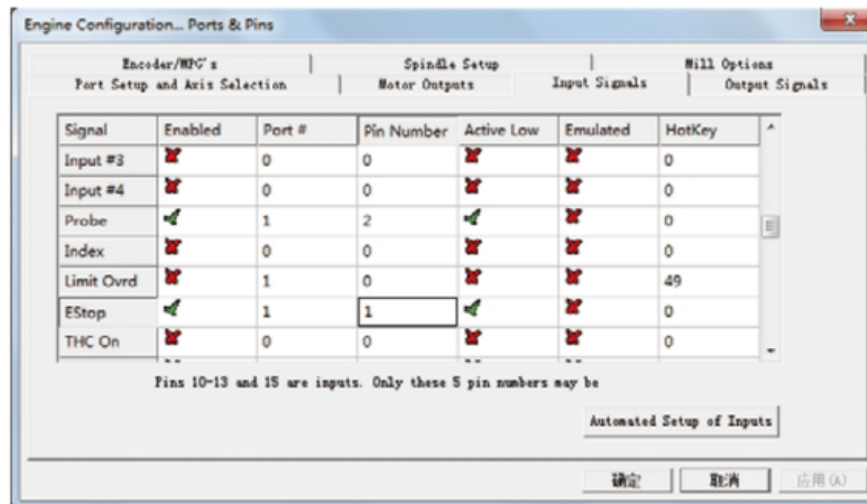

Click “Spindle Setup” switch to the spindle settings page.

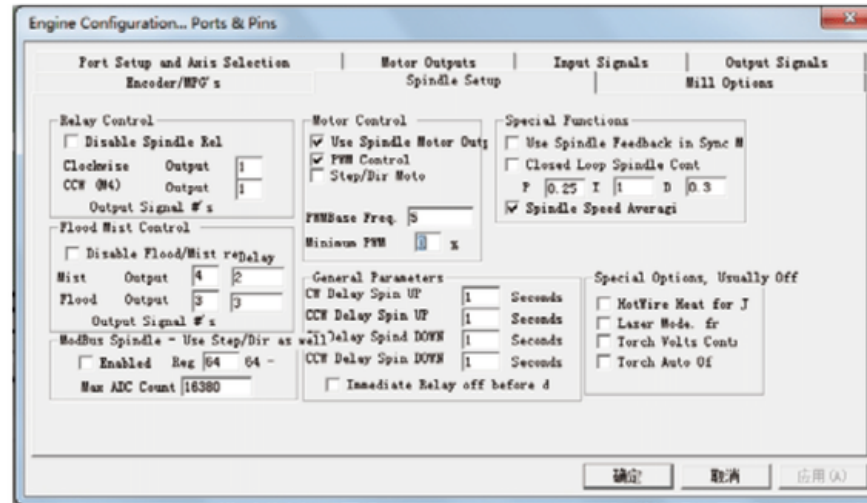

Here we can configure the spindle rotates CW、Reverse CCW、Mist、Flood pin.,They have been configured as 1、2、3、4. Corresponding to output#1~output#4 in Figure4-11.output#1~output#6 in Output Signal Setup dialog can be Configured into these 4 signals. Here we only configure CW/MIST/FLOOD. CW is controlled by OUT1. MIST is controlled by OUT2. Flood is controlled by OUT3. Here we note correspondence between 2 page. Please select “use spindle motor output” if required PWM speed spindle. And select “PWM Control”. Our PWM pin fixedly arranged on a special pin on Stepper motor setting dialog.

Here by our controller we already define all the Output Ports to Port No. 2.

All Output Ports are defined to Port No. 2.

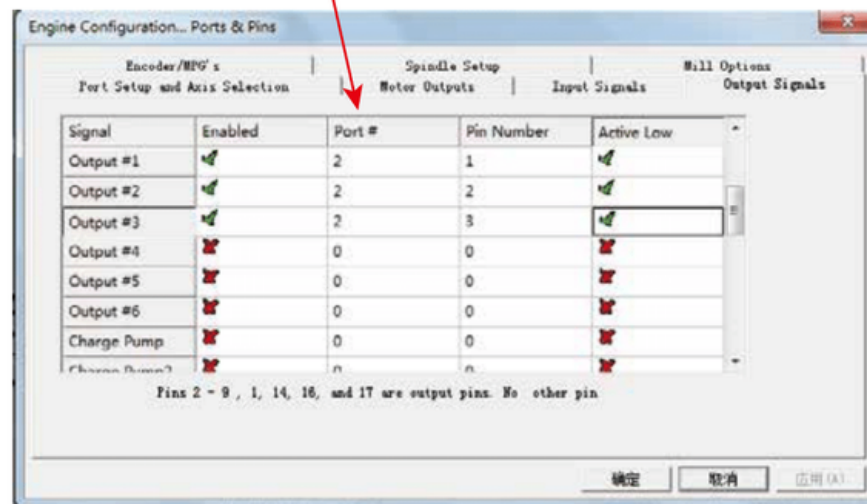

Spindle setting corresponds to the output configuration

6.6 MPG Settings

Firstly pls note the Picture 5-1 and the making No. 6,switch to the type of the MPG that you want,and connect the MPG pins in right way as the description of Page 11(Function Switch for MPG),then go to Mach 3 and Menu -> Config -> Config Plugins

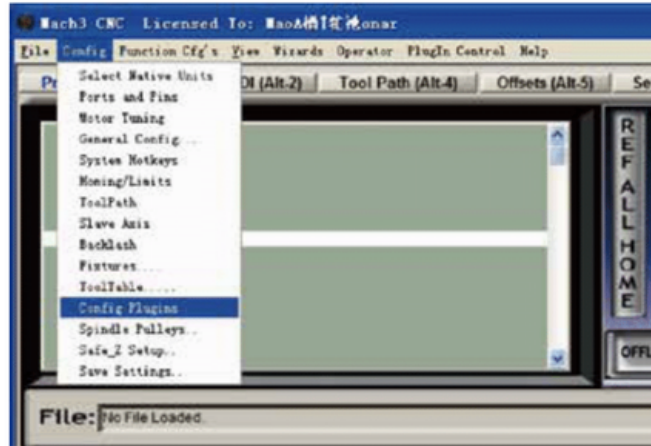

Then the following window will popup,click the “CONFIG” of the DigitalDream dll as following,there will be the selection windows for NV-MPG and standard MPG.The user have to select the right MPG type as their request.

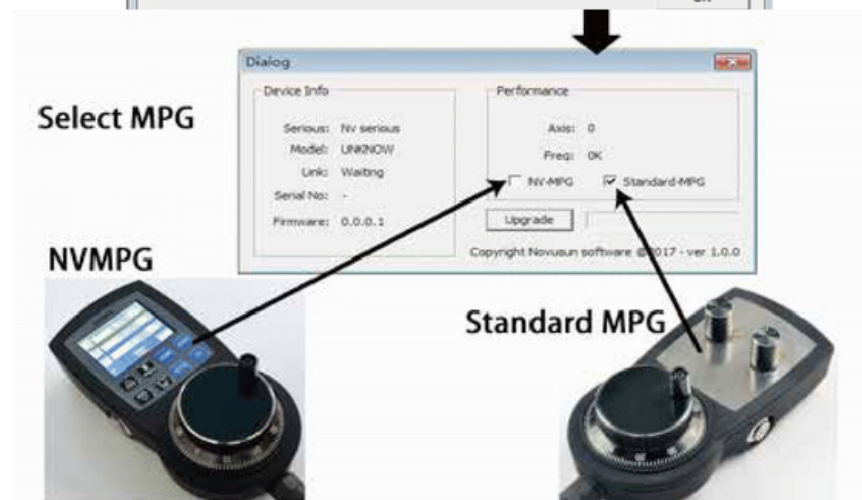
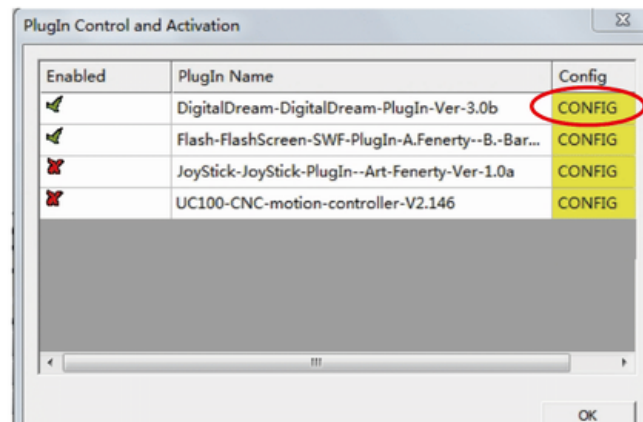

After the MPG selection done, we will go to setup the the MPG at Mach3 Software.
Go to Mach 3 and Menu -> Config -> Ports & Pins -> Encoder/MPG's as following.

Port Setup and Axis Selection Encoder/MPG's		Motor Outputs Spindle Setup				Input Signals	Output Signals Mill Options
Signal	Enabled	A -Port #	A -Pin #	B -Port #	B -Pin #	Counts/...	Velocity
Encoder1	<input checked="" type="checkbox"/>	0	0	0	0	1.000000	100.0000...
Encoder2	<input checked="" type="checkbox"/>	0	0	0	0	1.000000	100.0000...
Encoder3	<input checked="" type="checkbox"/>	0	0	0	0	1.000000	100.0000...
Encoder4	<input checked="" type="checkbox"/>	0	0	0	0	1.000000	100.0000...
MPG #1	<input checked="" type="checkbox"/>	0	0	0	0	1.000000	100.0000...
MPG #2	<input checked="" type="checkbox"/>	0	0	0	0	1.000000	100.0000...
MPG #3	<input checked="" type="checkbox"/>	0	0	0	0	1.000000	100.0000...

Then to active the MPG function, you can use the hand pulse, under the main page, click TAB to active MPG panel, refer to the following Picture:

