

Boring & Milling Head Unit

Modelo	S35	S35H
Spindle	MT3 or ER32	
Max. RPM	3000	10000
Rolamentos	32007 / 6007Z 32006 / 6006Z	7007×2 7006×2
Roundness	Within 0.003mm	
Max. Power	Within 1 HP	
Rising Temperature	Within 20°C	

S35-ER32-MF
S35-MT3-MF

PESO 30 kg

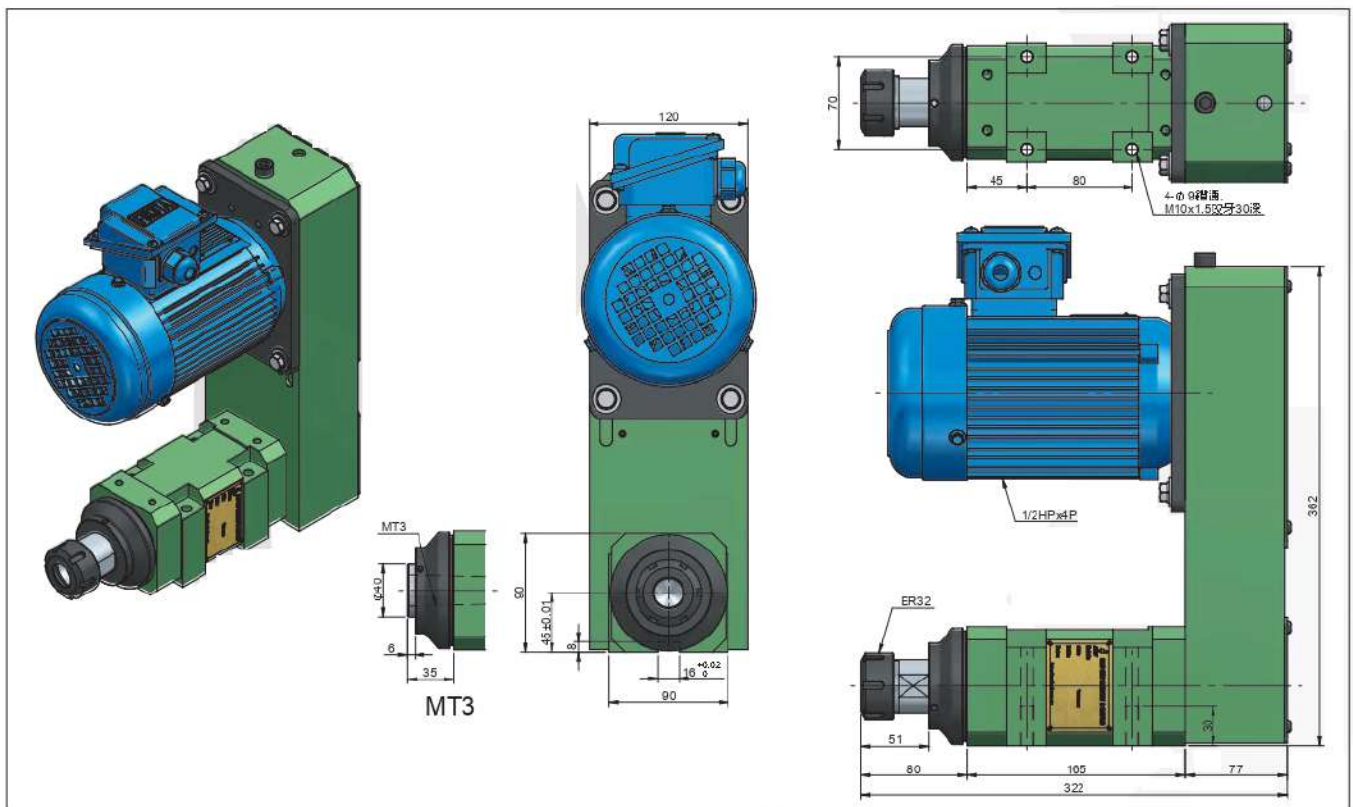

Boring & Milling Head Unit

S35-ER32-MB
S35-MT3-MB

PESO	30 kg
------	-------

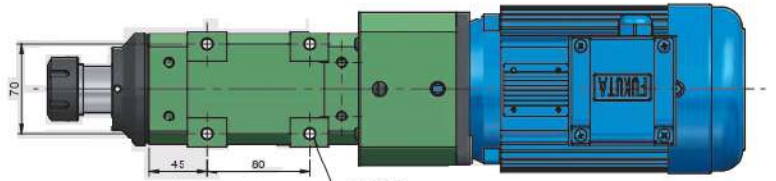
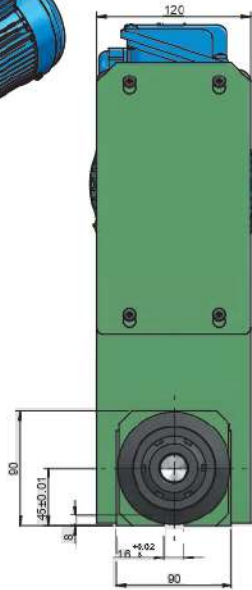
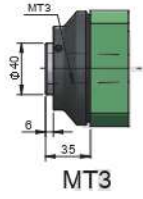
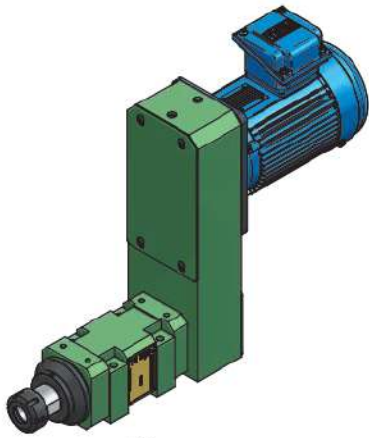

4-φ 9 螺孔
M10x1.5 攻牙30深

