



# PRADO

AUTOMAÇÃO INDUSTRIAL

## HYBRID STEPPER MOTOR type:

57HC79-8206A08-B35

SPECIFICATIONS				diagram
ângulo de passo	1.2° ±5%	corrente	5.8A	
fases	3	resistência	1.05 ±10% Ω	
Resistência de Isolamento	100MΩ (500V DC)	Indutância	1.3 ±20% mH	
Classe de Isolamento	B	holding torque	15kg. cm	

Dimension Unit: mm

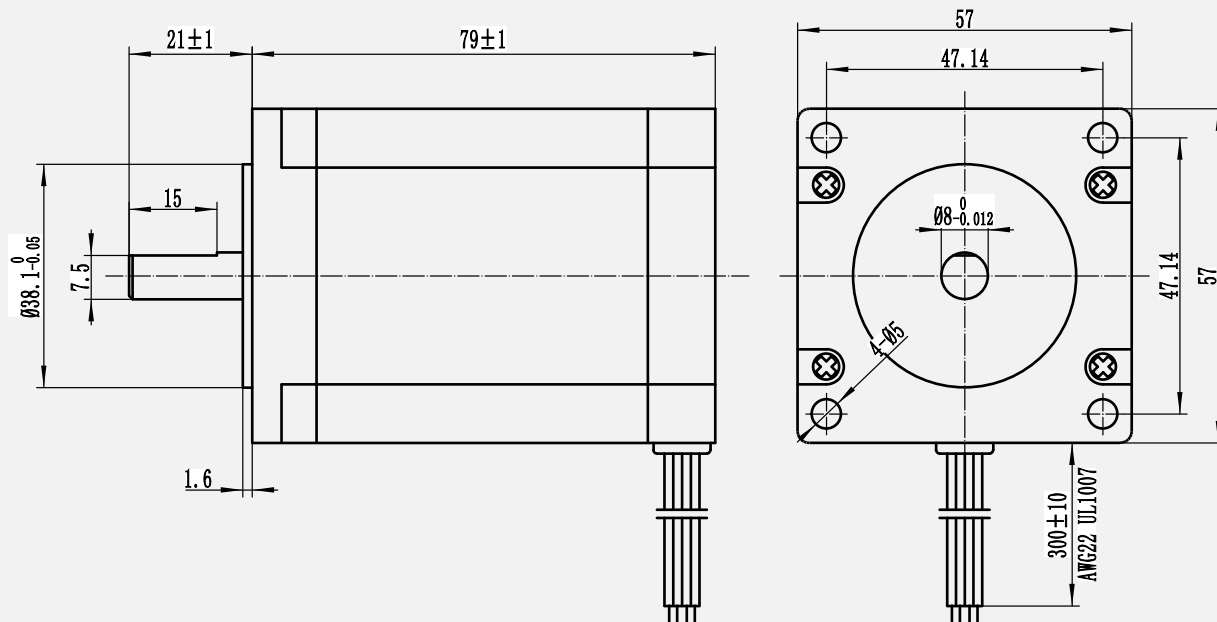

Design	Date	Check	Date	Approve	Date
--------	------	-------	------	---------	------



<https://pradoautomacaoindustrial.com.br>

email: vendas@pradoindustrial.com.br

(11) 5666-6461 / (11) 94242-8989 - WhatsApp