



# PRADO

AUTOMAÇÃO INDUSTRIAL

Motor de passo modelo: 86HS100-5008A14-B35

ESPECIFICAÇÕES						DIAGRAMA
Âng. de Passo	1.8° ± 5%	Corrente	5A	2,5A	3,5 A	
Nº de Fase	4	Resistência	0,5 ± 10% Ω	2 ± 10% Ω	1 ± 10% Ω	
Resist. de Isolação	100 MΩ (500VDC)	Indutância	6 ± 20% mH	16 ± 20% mH	4 ± 20% mH	
Classe de Isolamento	B	Holding Torque	65 kgf.cm	65 kgf.cm	45 kgf.cm	
		Tipo de conexão:	Paralelo	Série	Unipolar	
Ligação no driver:	Paralelo	A+ Vermelho/Azul A- Amarelo/Preto	B+ Branco/Marrom B- Laranja/Verde			
	Série	A+ Vermelho A- Preto Amarelo/azul	B+ Branco B- Verde Laranja/Marrom			
	Unipolar	A+ Vermelho A- Preto CM Amarelo/azul	B+ Branco B- Verde CM Laranja/Marrom			

## DIMENSÕES (mm)

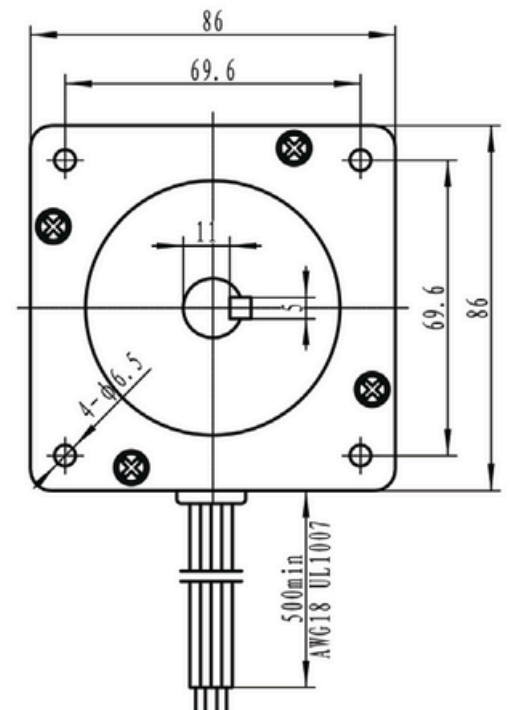
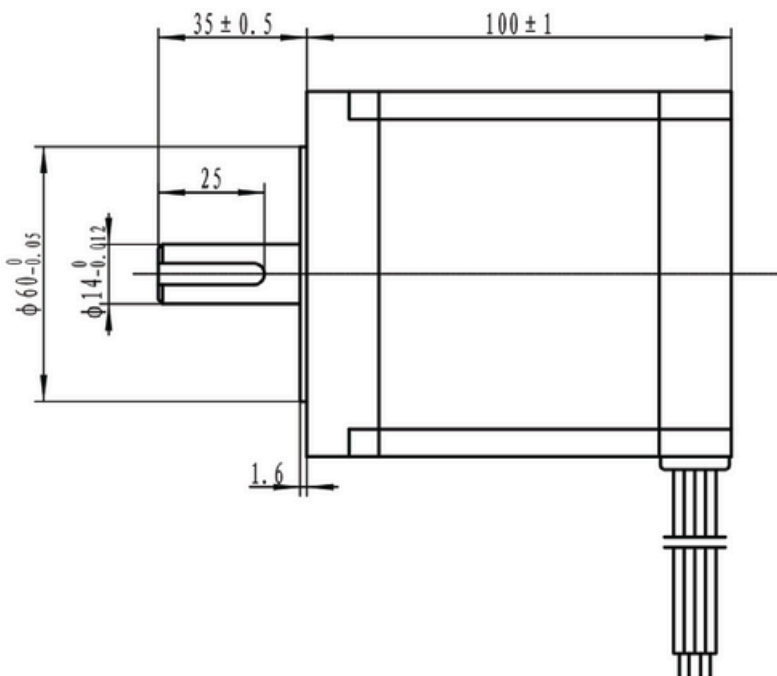

Design	Date	Check	Date	Approve	Date
--------	------	-------	------	---------	------



<https://pradoautomacaoindustrial.com.br>

email: vendas@pradoindustrial.com.br

(11) 5666-6461 / (11) 94242-8989 - WhatsApp



# PRADO

AUTOMAÇÃO INDUSTRIAL

## CURVA DE TORQUE

CONDIÇÕES DE TESTE: 48V 5,14A 400P/R LIGAÇÃO PARALELA

speed	rpm	60	120	240	360	480	600	660	780	900	960
Torque	kg.cm	44.00	40.00	34.00	28.50	22.50	17.50	15.00	13.00	10.00	9.00

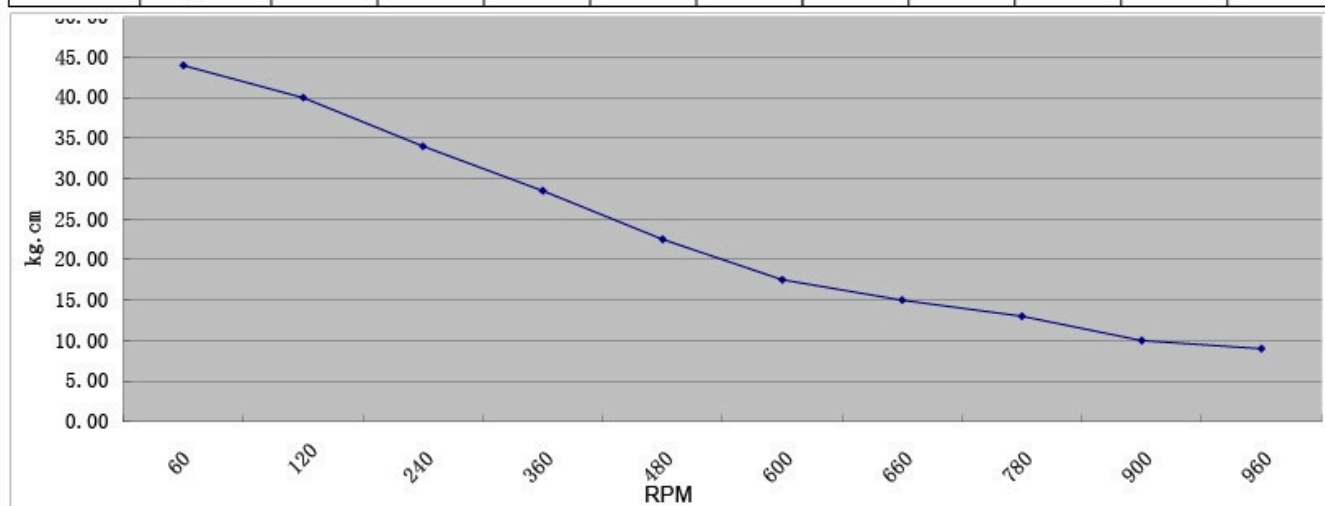

<https://pradoautomacaoindustrial.com.br>

email: vendas@pradoindustrial.com.br

(11) 5666-6461 / (11) 94242-8989 - WhatsApp